

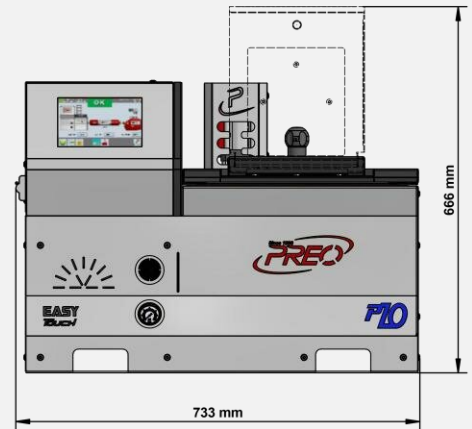

EASY TOUCH P10

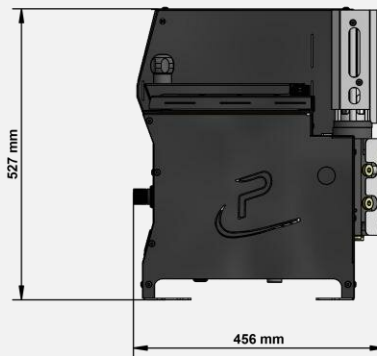
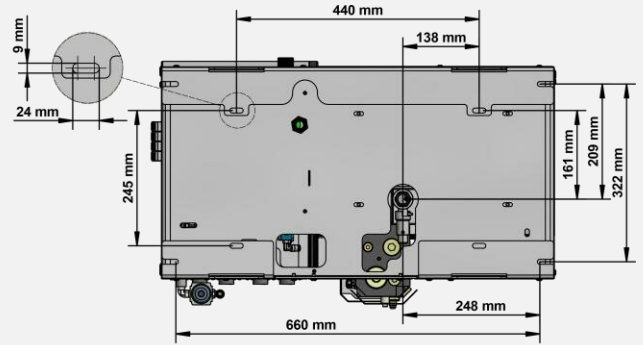

GENERAL SPECIFICATIONS

ADHESIVE TYPOLOGY AND VISCOSITY	hot-melt up to 30.000 Cps
OPERATING TEMPERATURE	50°C÷210°C (120°F÷410°F) standard version
HOSE/GUN CONNECTIONS	2, 4, 6, 8 (fitting thread 1/2"x20 UNF)
TANK CAPACITY	10 kg (22 lb)
MELTING RATE	11 kg/h *
WEIGHT (EMPTY)	75 kg (165 lb)
MACHINE DIMENSIONS (LxHxW MM)	733 x 666 x 456 mm
TANK OPENING DIMENSIONS (MM)	180 x 184 mm
TANK	internally coated with PTFE scratch-resistant non-stick treatment, heated fins and quick drain valve
MANIFOLD	coated with hard oxidation treatment and glue filter integrated
WARM-UP TIME	35'±40' starting from ambient temperature (0°C÷45°C (32°F÷113°F))
FASTENING	slots for M8 screws

ELECTRICAL SPECIFICATIONS

VOLTAGE	1/N/PE AC 230 V + 10% 50/60 Hz, 3/N/PE AC 400V + 10% 50/60 Hz
WATTAGE (without hoses and guns)	3,5kW (16 A)
MAXIMUM POWER PER CHANNEL	1,0 kW

MICROPROCESSOR SPECIFICATIONS

TEMPERATURE CONTROL	PT100 + 0, 5°C (1°F) - Ni120 e NTC (on request)
MICROPROCESSOR	7" Resistive Touch Screen - LCD TFT LED lighted colour display - resolution 800x480 pixel (USB, Ethernet, and Windows CE software)
FUNCTIONS	Economy, Clock, Weekly Program, Maximum Temperature Alarm, Sequential Heating Zones
SAFETIES	by-pass safety valve, over-temperature automatic protection, emergency stop input alarm, glue pressure release, "real time" diagnostics
OPTIONS	level sensor, quick pressure release valve and flow regulation, integrated glue pattern control, automatic filling system

PNEUMATIC PUMP SPECIFICATIONS

PUMP TYPE	double acting pneumatic piston pump ratio 14:1
REVERSING SYSTEM	electro-magnetic with end stroke sensors
MAXIMUM PUMP RATE	35 kg/h *
WORKING PRESSURE	0,3÷5,0 bar
MAXIMUM WORKING PRESSURE	55 bar

*(depending on used adhesive typology)

© Copyright 2020 PREO SRL - All rights reserved - Subject to change without advanced notice - Printed in Italy - Edition EN-100 EASY TOUCH P10.DOCX - 22/01/2020

