

User manual

Inorecip H

SAMES KREMLIN SAS - 13, Chemin de Malacher - 38240 MEYLAN - FRANCE
Tel. 33 (0)4 76 41 60 60 - www.sames-kremlin.com

All communication or reproduction of this document, in any form whatsoever and all use or communication of its contents are forbidden without express written authorisation from **SAMES KREMLIN**.

The descriptions and characteristics mentioned in this document are subject to change without prior notice.

© **SAMES KREMLIN 2020**



WARNING : **SAMES KREMLIN SAS** is registered with the Ministry of Labour as a training institution.

Throughout the year, our company offers training courses in the operation and maintenance of your equipment.

A catalogue is available on request. Choose from a wide range of courses to acquire the skills or knowledge that is required to match your production requirements and objectives.

Our training courses can be delivered at your site or in the training centre at our Meylan head office.

Training department:

Tel. 33 (0)4 76 41 60 04

E-mail: formation-client@sames-kremlin.com

SAMES KREMLIN SAS operating manuals are written in French and translated into English, German, Spanish, Italian and Portuguese.

The French version is deemed the official text and **SAMES KREMLIN** will not be liable for the translations into other languages.

Inorecip H

1. Health and safety instructions - - - - -	4
1.1. Marking	4
1.2. Simplified analysis of potential ignition sources according to EN 80079-36	4
1.3. Precautions for Use	5
1.4. Warnings	5
1.5. Important recommendations	7
1.5.1. Installation du chariot gabarit Inorecip H.	7
1.5.2. Maximum speed of the Inorecip H	7
1.5.3. Vibrations of the Inorecip H	7
1.5.4. Ambient temperature.	7
1.6. Guarantee	8
2. Introduction - - - - -	9
2.1. General	9
2.2. Description	10
3. Characteristics - - - - -	11
3.1. Dimensions (mm)	11
3.2. General characteristics	11
4. Startup - - - - -	12
4.1. Tools	12
4.2. Installation	12
4.2.1. Installation on the floor	12
4.2.2. Electrical connection Inorecip H - Control module	12
4.2.3. Ground connection	13
4.3. Adjusting the tension of the toothed belt	13
5. Maintenance - - - - -	14
5.1. Summary table of maintenance operations	14
5.2. Maintenance	14
5.3. Replacement	15
5.3.1. Procedure C1: Replacing the toothed belt.	15
5.3.2. Procedure C2: Replacing the carriage rollers.	16
5.3.3. Procedure C3: Replacing the coder.	16
6. Troubleshootings - - - - -	17
7. Spare parts list - - - - -	18
7.1. Inorecip H	18
8. Revision index History - - - - -	19

1. Health and safety instructions

This manual contains links to the following instructions manuals:

- [see RT Nr 7140](#) for **Inorecip V** and **Inomotion**.

1.1. Marking

Inorecip H is classified as category 3 according to the ATEX 2014/34/EU directive and is designed for use in zone 22.

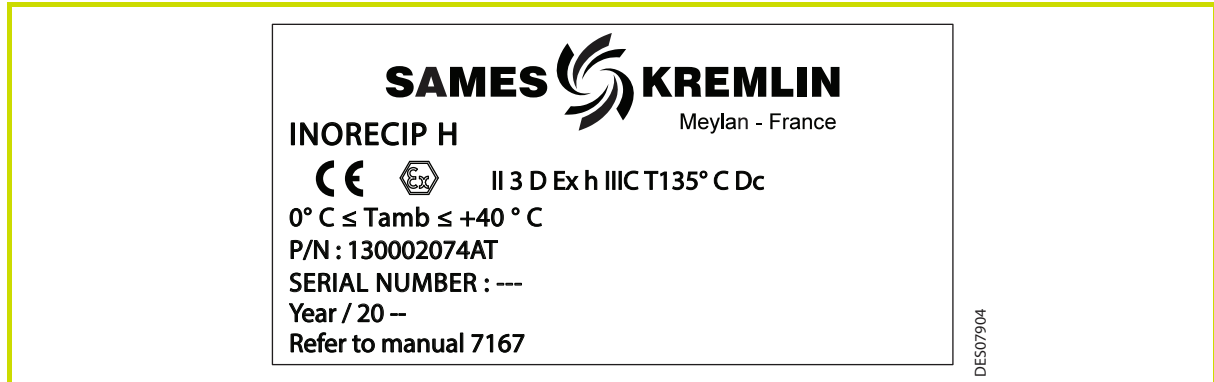

1.2. Simplified analysis of potential ignition sources according to EN 80079-36

Risk of ignition		Measures applied to prevent the source of ignition from becoming effective
Potential source of ignition	Description / Main cause (What are the conditions causing the risk of ignition)	Description of the measure applied
Hot surface	Friction of the drive belt on the pulleys and of the rollers on the rails	Plastic belt: does not transmit heat Moving speed < 36m/min
Sparks of mechanical origin	Sparks caused by the fall of the carriages (belt breaking) or by a change in the stroke of the carriages	Carriages equipped with high and low elastic stops
Static electricity	Electrostatic discharge between metal parts and earth (e.g. rollers / rails, pulley / axis / belt)	All metal parts must be earthed.
	Electrostatic discharge at the belt	Antistatic belt

1.3. Precautions for Use

This document contains information that all operators should be aware of and understand before using the **Inorecip H**. This information highlights situations that could result in serious damage and indicates the precautions that should be taken to avoid them.



WARNING : Before any use of the **Inorecip H**, check that all operators:

- have previously be trained by the compagny **SAMES KREMLIN**, or by their distributors registered by them for this purpose.
- have read and understood the user manual and all rules for installation and operation, as laid out below.

It is the responsibility of the operators' workshop manager to ensure these two points and it is also his responsibility to make sure that all operators have read and understood the user manuals for any peripheral electrical equipment present in the powdering area.

1.4. Warnings



CAUTION:

It is imperative that anyone wearing a pacemaker does not use the equipment and does not enter the projection area.

High voltage can cause the pacemaker to malfunction.



WARNING : Safety may be jeopardized if this equipment is not operated, disassembled and reassembled in compliance with the instructions given in this manual and in any European Standard or national safety regulations in force.



WARNING : Equipment performance is only guaranteed if original spare parts distributed by **SAMES KREMLIN** are used.



WARNING : This equipment must only be used in projection locations in accordance with EN 16985. The equipment should only be used in well-ventilated areas to reduce health, fire and explosion hazards. The efficiency of the exhaust ventilation system must be checked daily.

- 1 The operator must wear shoes according to standard EN ISO 20344 and the insulation resistance measured must not exceed 100 MΩ.
- 2 The protective clothes, including gloves, must conform to standard EN 1149-5 and the insulation resistance measured must not exceed 100 MΩ.
- 3 Using individual protection equipment will limit the risks of contact and/or inhalation of toxic product, gas, vapours, fog or dusts that can be produced while using the equipment. The user has to follow the coating product manufacturer's recommendations.

- 4 Appropriate measures must be taken to prevent, during periods of non-use and/or when the equipment is out of service, that potential energy is present in the equipment.
- 5 The ambient operating temperature must be between 0 and 40°C.
- 6 The **Inorecip H** equipment must be maintained regularly in accordance with the indications and instructions given by **SAMES KREMLIN**.
Repairs must be carried out in strict accordance with these instructions.
- 7 Inside the booth it is forbidden to use naked flames, glowing objects or devices likely to produce sparks.
It is also forbidden to store flammable products, or recipients that have contained them, in the vicinity of the booth.
The surrounding area must be kept clear and clean.
- 8 Earthing is required of all conductive enclosures of electrical equipment and all conductive components in potentially explosive atmospheres by conductive connection to the earth terminal.
- 9 It will be necessary, in the spraying area, to have an antistatic floor such as bare concrete, metal grating, etc... It is imperative that the spray booths are properly ventilated to avoid any accumulation of flammable vapors.
- 10 Disconnect, lock out and turn off electrical equipment before servicing electrical equipment.
- 11 In case of an emergency, the equipment can be switched off via emergency stop buttons located on the powder booth.
- 12 Do not start the powder application with **Inorecip H** until the ventilation system of the spray booth is switched on. If the ventilation is switched off, toxic substances or dust may remain in the spray booth and cause a risk of fire, poisoning or irritation.
- 13 Switch off all electrical or electrostatic equipment immediately, even if you are exposed to a slight electric shock. Do not restart the equipment until the problem has been diagnosed and resolved.

1.5. Important recommendations

1.5.1. Installation du chariot gabarit **Inorecip H**

Les ensembles doivent être installés sur un sol plat et ayant une résistance de 40 daN/cm².

Les charges admissibles sur l'**Inorecip H** sont de 250 kg à une vitesse égale à 9 m/min.

1.5.2. Maximum speed of the Inorecip H

The **Inorecip H** has a speed equal to 9 m/min at 50 Hz.



WARNING : Access to the operation area when using Inorecip H shall be regulated and/or limited by means of a standard protective wire mesh enclosure.

1.5.3. Vibrations of the Inorecip H

If the assembly vibrates in an unusual way, it means that usually:

- The belt is slack or worn.



WARNING : The guarantee does not cover damage caused by loads that are too high in relation to those recommended and/or with an overhang greater than that recommended.



WARNING : Start-up and use of the Inorecip H must comply with the Machinery Directive and EN 60204-1 (safety of machinery).

1.5.4. Ambient temperature

Inorecip H is designed to normally operate at an ambient temperature comprised between 0°C and + 40°C.

The storage temperature must never exceed +60°C.

1.6. Guarantee

Under the guarantee, which applies only to the buyer, **SAMES KREMLIN** agrees to repair operating faults resulting from a design fault, materials or manufacture, under the conditions set out below.

The guarantee claim must define the exact nature of the fault concerned, in writing. The **SAMES KREMLIN** guarantee only covers equipment that has been serviced and cleaned according to standard procedures and our own instructions, that has been fitted with parts approved by **SAMES KREMLIN** or that has not been modified by the customer.

More precisely, the guarantee does not cover damage resulting from:

- the customer's negligence or inattention,
- incorrect use,
- use of a control system not designed by **SAMES KREMLIN** or a **SAMES KREMLIN** control system modified by a third party without written permission from an authorized **SAMES KREMLIN** technical agent,
- failure to follow procedures,
- accidents such as: collision with external objects, or similar events,
- flooding, earthquake, fire or similar events,

The **SAMES KREMLIN Inorecip H** is covered by a warranty (refer to the general sales conditions for its application).

The guarantee does not apply to wearing parts.

The guarantee will take effect from the date of the first start-up or of the provisional acceptance report.

Under no circumstances, either in the context of this guarantee or in other contexts, will **SAMES KREMLIN** be held responsible for physical injury or intangible damage, damage to brand image and loss of production resulting directly from its products.

2. Introduction

2.1. General

The **Inorecip H** is a carriage placed under the **Inorecip V** robot giving it the possibility to move on a second horizontal axis. The "in and out" movement is provided by a gear motor (composed of an asynchronous motor and a gearbox). It allows the **Inorecip V** and **Inorecip H** unit to powder parts of different widths on automatic powder coating machines.

It is composed of a mechanism remotely controlled by a control software (**Inomotion**) placed inside an independent box or in an electrical cabinet.

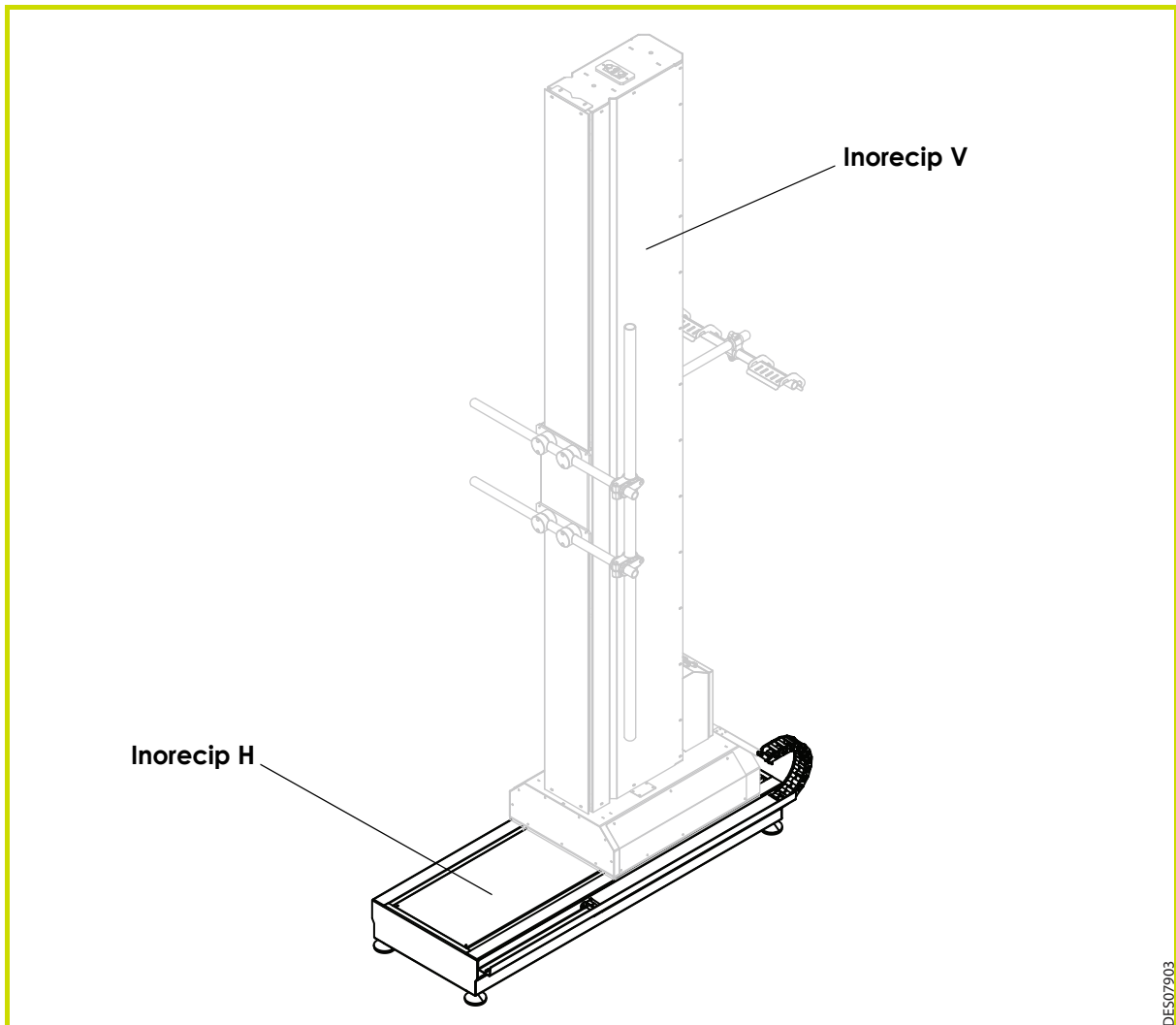

2.2. Description

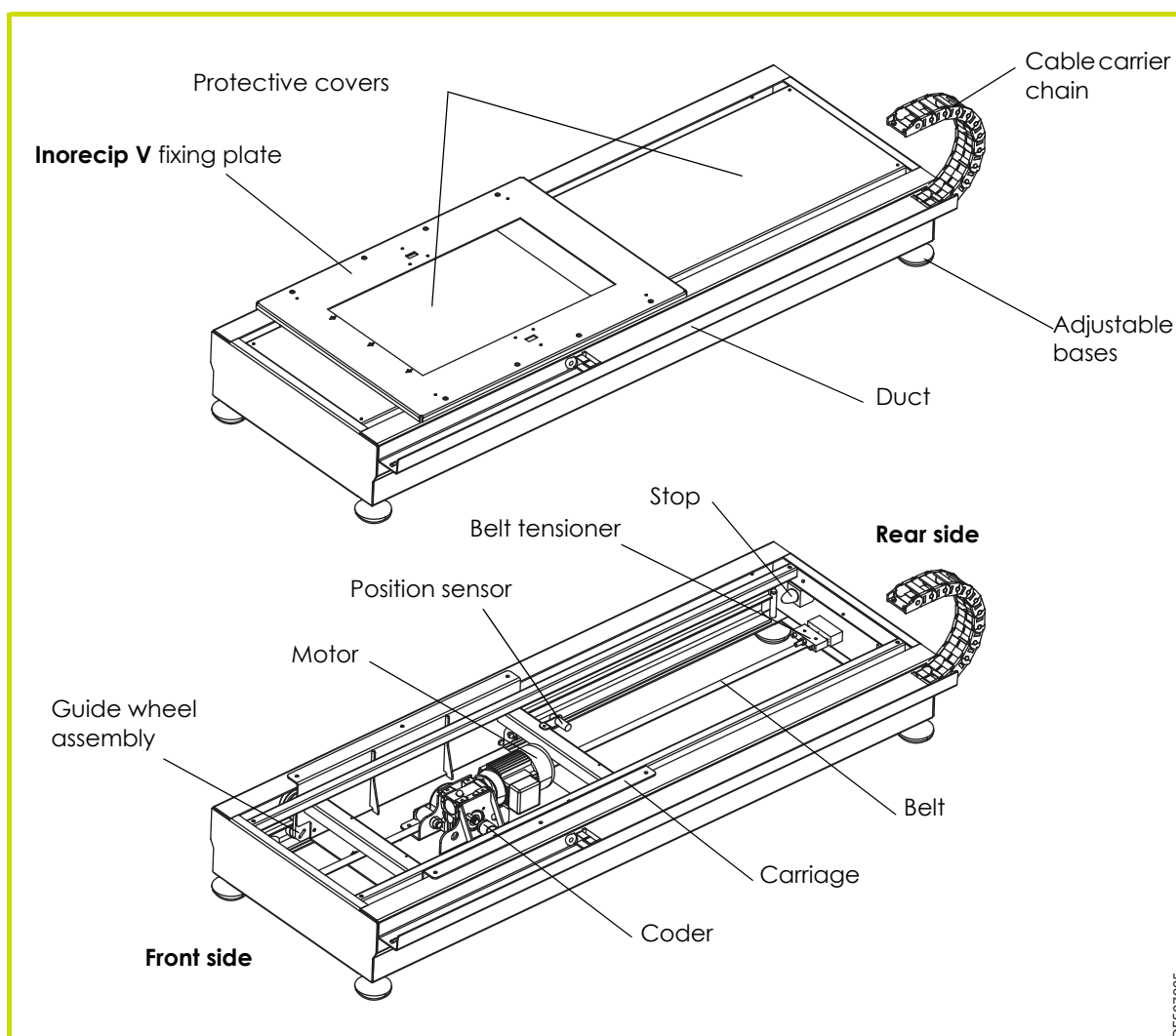

DES07905

Element	Function
Fixing plate	Support for fixing the Inorecip V to the carriage
Cable carrier chain	Mobile guide for electrical cables
Adjustable bases	Allows the adjustment of the cart's level
Duct	Support of the cable carrier chain
Stop	The carriage has 4 end stops
Protective covers	Two-part protective covers of the cart
Belt tensioner	Allows adjustment of the tension of the toothed belt
Position sensor	Detects the position of the carriage
Motor	Motor equipped with a gear motor and a coder
Guide wheel assembly	4 sets equipped with carriage guide wheels
Antistatic toothed belt	Carriage drive belt
Carriage	Assembly allowing the horizontal movement of the Inorecip V equipped with powder projectors
Coder	Coder linked to the motorization unit

3. Characteristics

3.1. Dimensions (mm)

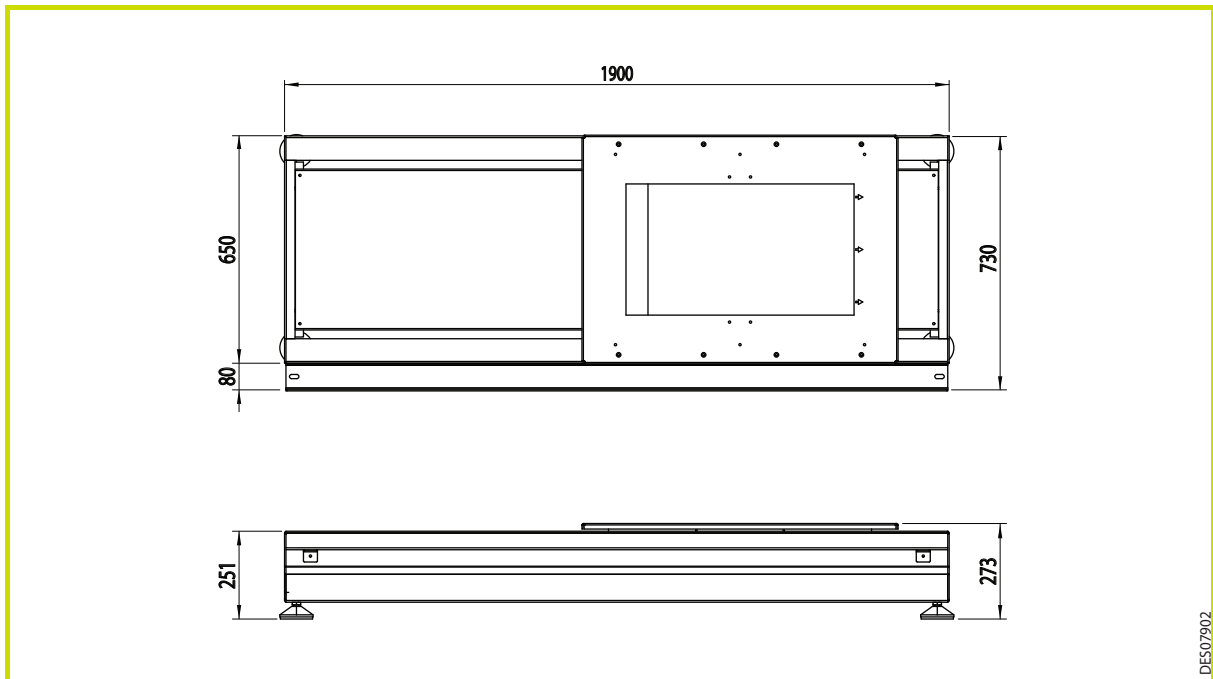

3.2. General characteristics

Inorecip H	
Stroke adjustment	up to 1 m
Movement speed	continuously adjusting max. 9 m/min
Empty weight	approx. 150 kg
Geared motor power	0.18 kW
Load capacity	300 kg
Single-phase power supply	230 VAC \pm 10%
Operating temperature	+0° C - 40° C
Frequency	50 - 60 Hz

4. Startup

4.1. Tools

The tools listed below should be available for product installation and maintenance operations.

- Flat screwdriver.
- Phillips screwdriver.
- Allen wrenches.
- Torque wrench.
- Flat wrench 17 mm.
- Pipe wrench.
- Multi-socket pliers.

4.2. Installation

4.2.1. Installation on the floor

As the location of Inorecip H has been defined in relation to the location of the powder booth ([see RT Nr 7140](#)), it is **imperative** to position the front side of Inorecip H towards the powder booth. The rear of the equipment is on the side of the belt tensioner.

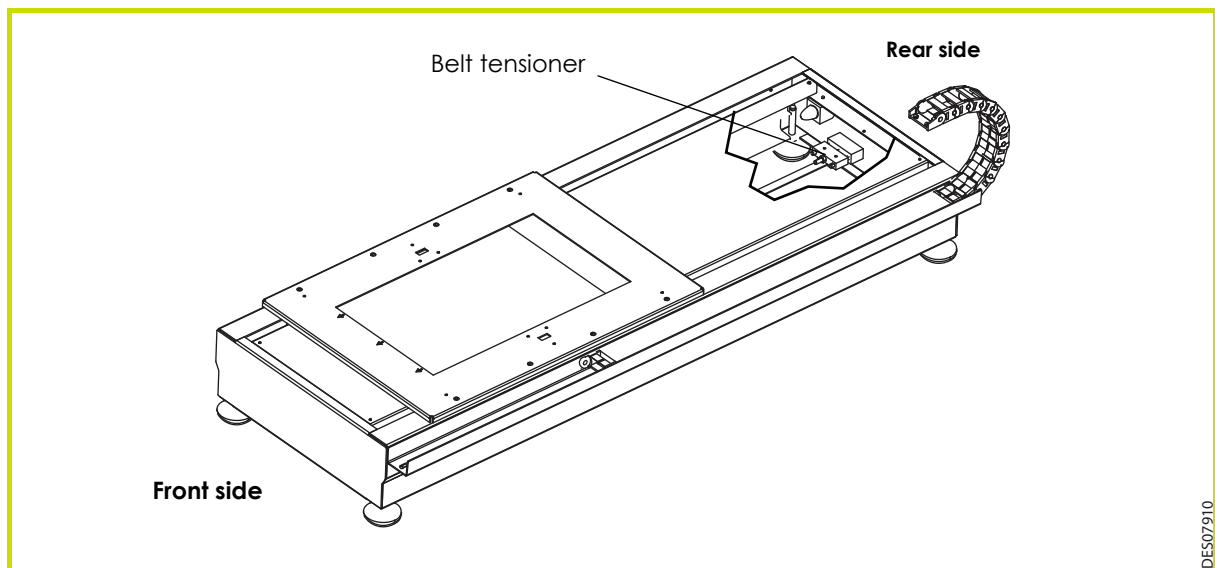

4.2.2. Electrical connection Inorecip H - Control module

Install the 2nd axis box transformation cable kit (Ref.:130002077) by connecting the **Inorecip H** cables to the **Inorecip V** electrical box. ([see RT Nr 7140](#)).

4.2.3. Ground connection



WARNING : It is imperative to connect the Inorecip H to the ground of the control module or to a good quality ground.

From the control module or a good quality ground, connect a green/yellow conductive protective grounding cable to the brass screw (A) located on the base of the **Inorecip V**.

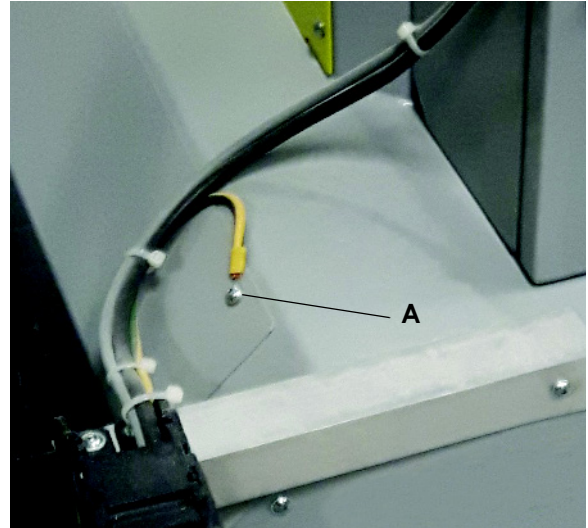

4.3. Adjusting the tension of the toothed belt



WARNING : It is imperative to use an antistatic toothed belt on the Inorecip H.

Belt tension adjustment procedure:

- **Step 1:** Remove the protective cover.
- **Step 2:** Using a 17 mm open-end wrench, adjust the tension using the M10 nut.
- **Step 3:** Replace the protective cover.

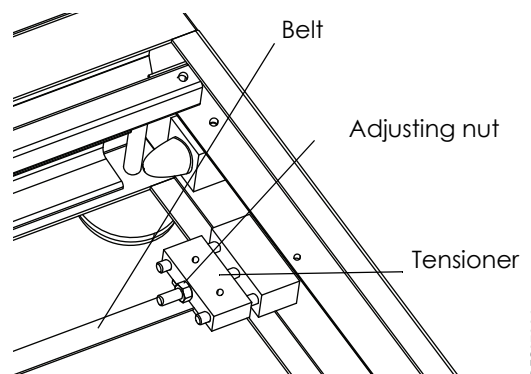

DE507906

5. Maintenance



WARNING : Before any intervention on the Inorecip H, it is imperative to cut off the power supply.

5.1. Summary table of maintenance operations

Therefore, the frequency of maintenance indicated in the procedures below is only indicative. The user will have to create his own maintenance range as he uses the **SAMES KREMLIN** equipment.

Procedure	Detail	Duration	Frequency	
Maintenance				
A	Checking the condition and tension of the antistatic toothed belt	10 min	2 times a year	
B	Checking the freedom of movement of the rollers	10 min	2 times a year	
Replacement				
C	C1	Replacing the antistatic toothed belt	1 H	-
	C2	Replacing the carriage rollers	2 H	-
	C3	Replacing the coder	2 H	-

5.2. Maintenance



WARNING : All cleaning operations must be done only with compressed air. Water should never be used to clean equipment.

After the first 100 and 200 hours, then every 1000 hours (or twice a year):

- Check the condition and tension of the belt and adjust if necessary.
- Check that the rollers are free to roll freely:
 - Carriage rollers: The rollers at the corners of the carriage should be able to rotate easily but without excessive play. Check this at several points along the travel of the carriage. If necessary, use the set screws of each roller kit to adjust the guide.
- Clean the belt.

5.3. Replacement

5.3.1. Procedure C1: Replacing the toothed belt

The **Inorecip V** being previously removed from its support on the **Inorecip H** carriage.

- Remove the two protective covers
- Unscrew completely the adjusting nut of the belt tensioner and remove the toothed belt from the tensioner.

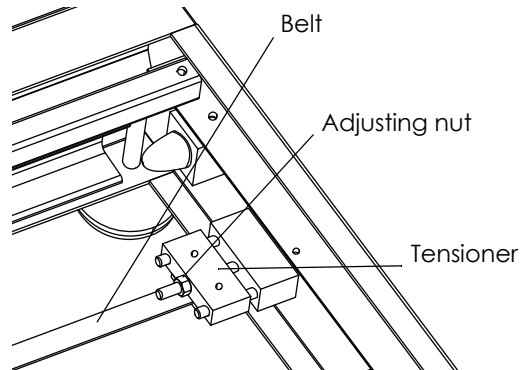

DE507906

- Remove the belt from the fixed support on the other end of the frame.
- Remove the belt from the drive toothed pulley and remove the belt completely.

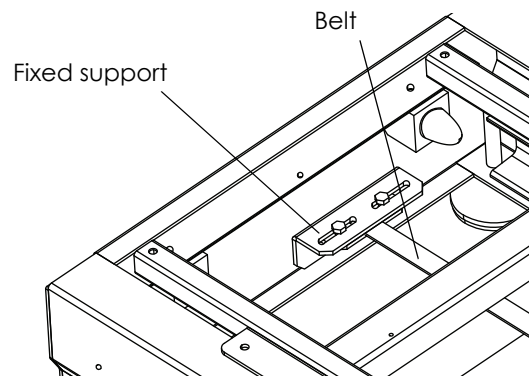

DE507908

- Attach the new belt to the fixed support, then pass the free end of the belt through the underside of the first roller and over the drive toothed pulley. Then pass the free end of the belt under the second roller.
- Attach the end to the belt tensioner and check the tension ([see § 4.3 page 11](#)).

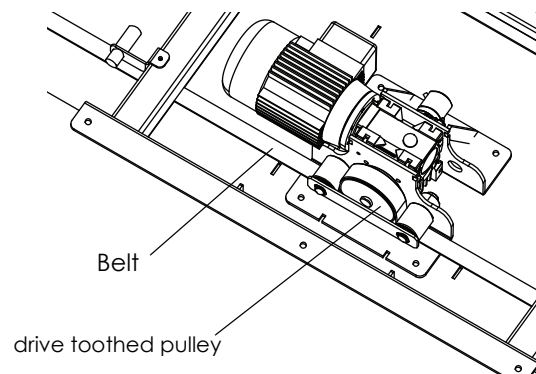

DE507909

5.3.2. Procedure C2: Replacing the carriage rollers



WARNING : When replacement of a roller is necessary, it is imperative to replace all 4 roller kits on the carriage

The **Inorecip V** being previously disassembled from its support on the **Inorecip H** carriage:

- Remove the two protective covers.
- Remove the three M8 screws from the roller kit and slide it on the guide rail to remove it.
- Proceed in reverse order for reassembly.
- If necessary, adjust the roller using the M5 screw.

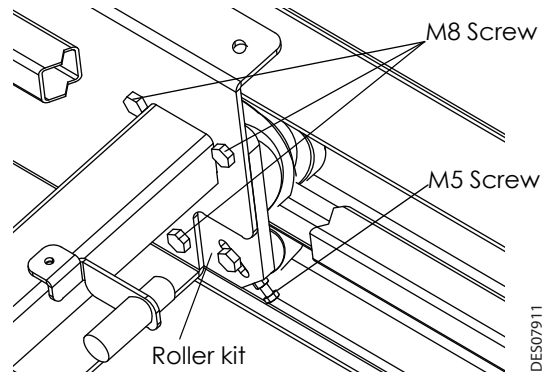

5.3.3. Procedure C3: Replacing the coder



WARNING : Disconnect the power supply to the Inomotion before any intervention on the Inorecip H

After 10,000 hours of operation, or in case of accidental damage, it is necessary to change the encoder.

Caution: it is very fragile and in particular its connection terminals.

To perform this operation, the Inorecip V must be removed from its support on the Inorecip H carriage:



WARNING : The handling of the Inorecip V must be performed by at least two operators using lifting equipment adapted to the weight and the size of the robot.

- Remove the two protective covers.
- Unscrew the coder cable.
- Remove the nut **(A)** from the encoder anti-rotation plate.
- Remove the encoder from the motor shaft by unscrewing the screw **(B)**.
- Remove the encoder anti-rotation plate by unscrewing the screws **(C)**.
- Proceed in the reverse order for reassembly.

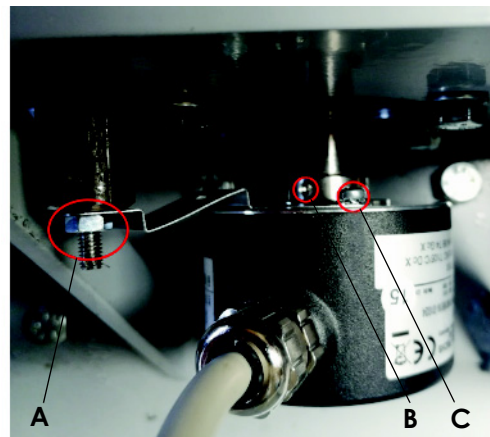

6. Troubleshootings

Symptoms	Probable causes	Remedies
Inorecip H operates, but there is a click sound when the movement is reversed.	The belt is slackened and causes a loss of carriage position	Tighten the belt
	The nuts of the belt fastening on the carriage are loosened	Tighten the nuts again
Vibrations of the moving carriage	Blocked or defective guiding rollers	Change the rollers
Oscillations of the moving carriage	Incorrectly adjusted rollers on the guiding profile	Adjust roller contact
	Overhang of the projectors on the Inorecip V	Bring the projectors closer to the axis of the carriage

7. Spare parts list

7.1. Inorecip H

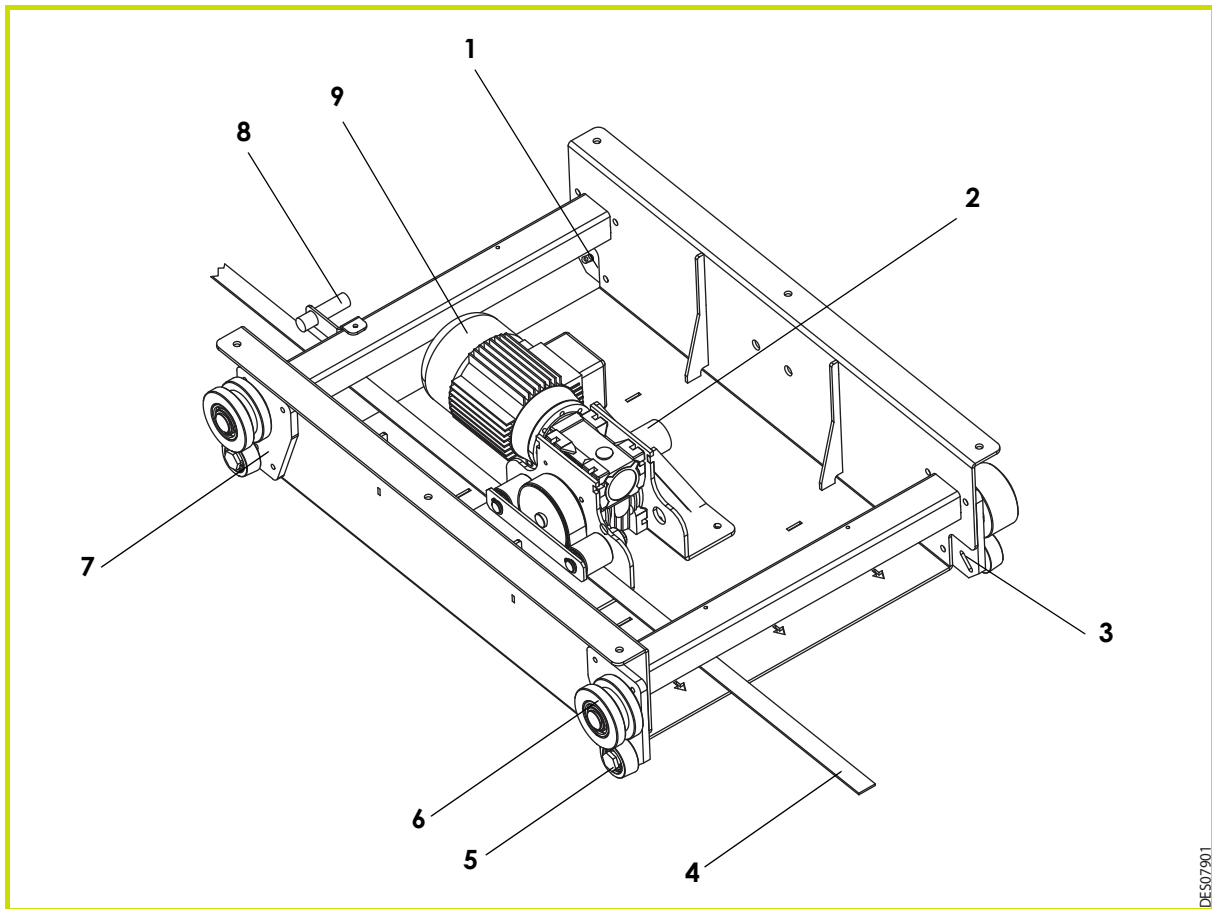

Item	Part Number	Description	Qty	Unit of sale	Maintenance level for spare parts (*)
	130002074AT	Inorecip H	1	1	3
1	130002093	Right wheel kit	1	1	3
2	110002896AT	Coder	1	1	3
3	130002090	Left wheel kit	1	1	3
4	130002089	Antistatic belt	1	1	3
5	130002094	Low wheel kit	1	1	3
6	130002091	Left wheel kit	1	1	3
7	130002092	Right wheel kit	1	1	3
8	110002897AT	Position sensor	1	1	3
9	110002898AT	Motor 0.18 kW	1	1	3

(*)

Level 1: Standard preventive maintenance

Level 2: Corrective maintenance

Level 3: Exceptional maintenance

8. Revision index History

Rev.	Date	Description	Modification locating
A	Nov. 2020	First issue	