



ELECTROMAGNETIC GUNS AND CONTROL UNITS STRAIN 121 AND STRAIN DRIVER



STRAIN 121

STRAIN 121 electromagnetic guns represent a new breakthrough in electric guns. They are particularly suitable for applying and supplying micro-points of thermal adhesives even at very high speeds of up to 5000 mPas. They can attain a cycle speed of less than 1 millisecond and an overall lifecycle of tens of millions of strokes. STRAIN 121 guns are the most sophisticated, innovative, and technologically advanced on the world market today and stand out from their competitors due to their speed, compactness, precision, repeatability in supply, and ease and speed of installation, as well as being completely noise free.

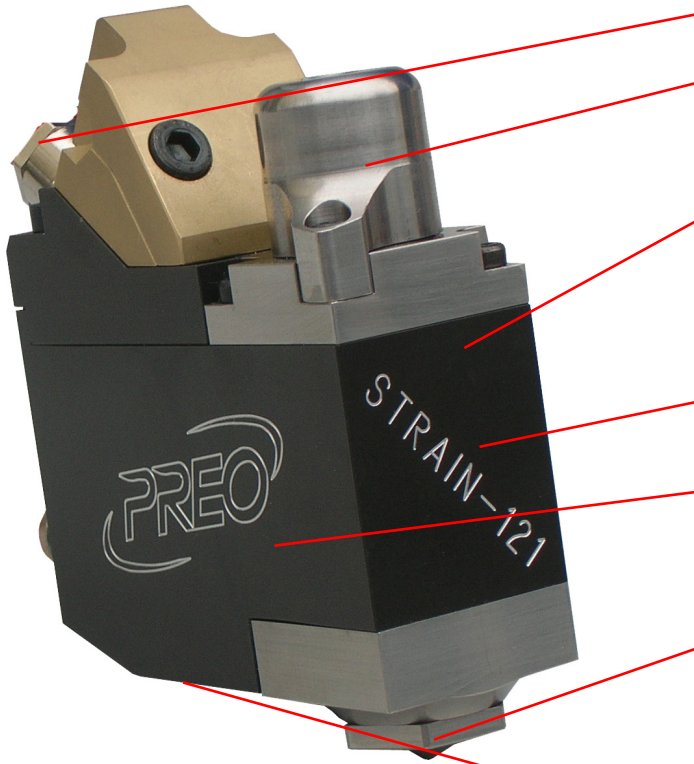

ELECTRICAL CONNECTIONS

The electrical kit is easy, quick, and safe to extract.

MICRO-REGULATION SYSTEM

A precise micro-regulation system guarantees simple, perfect formation of micro-points of glue, even at very high speeds.

HIGH SPEED ACTUATOR

This makes it possible to supply a glue point in less than 1 millisecond, with maximum repeatability and precision.

ENERGY SAVING

An innovative energy saving system makes it possible to recover up to 50% of the electricity used for the gun to operate.

INTEGRATED MODULE

All the gun's components are assembled inside the casing, which makes maintenance easier and reduces the quantity of spare parts required.

GUN CASING

The material used to make the gun casing is "Ergal", which significantly improves performance in terms of strength to resist mechanical forces. A hard oxide coating makes cleaning and maintaining the gun quicker and simpler.

"REDUCED CAVITY" NOZZLE

A removable "Reduced-Cavity" nozzle made of special high strength material guarantees maximum repeatability, exceptional reliability, and very high precision, as well as uniformity of the micro-points of glue deposited.

GLUE FILTER

The filter is integrated into the casing and it guarantees better distribution of the glue preventing nozzles from clogging due to the presence of impurities in the glue. It is easily accessible and can be quickly replaced without disassembling the hose.

STRAIN DRIVER

The STRAIN DRIVER 121 digital control unit runs up to 6 guns fully independently, for all functions and allows repeatability that far outstrips normal applications, thanks to its innovative electronics.



CONNECTIONS

Quick coupling connectors on the back of the unit are used to connect all the Input and/or Output signals and the photocells required for the system to operate properly.

GRAPHIC DISPLAY

An LCD provides a graphic display of the sections and the parameters that can be set for programming the guns. The graphic icons are easy to interpret, even by non-specialist personnel, eliminating problems generated by codes and foreign languages independently of the country of use.

PROGRAMMING SELECTOR

Another innovative feature is the programming method of all the operating parameters that is carried out through a single control consisting of a selector with built-in button. Every time the knob is pressed, another parameter appears, which is increased or decreased by turning the knob clockwise or anti-clockwise direction.

LIGHT INDICATORS

4 leds show the system status and any alarms or faults that arise while the unit is operating.

Distributed in

Australia by:



Contact
02 9645 3900
info@epacproductions.com.au

STRAIN 121 - TECHNICAL SPECIFICATIONS

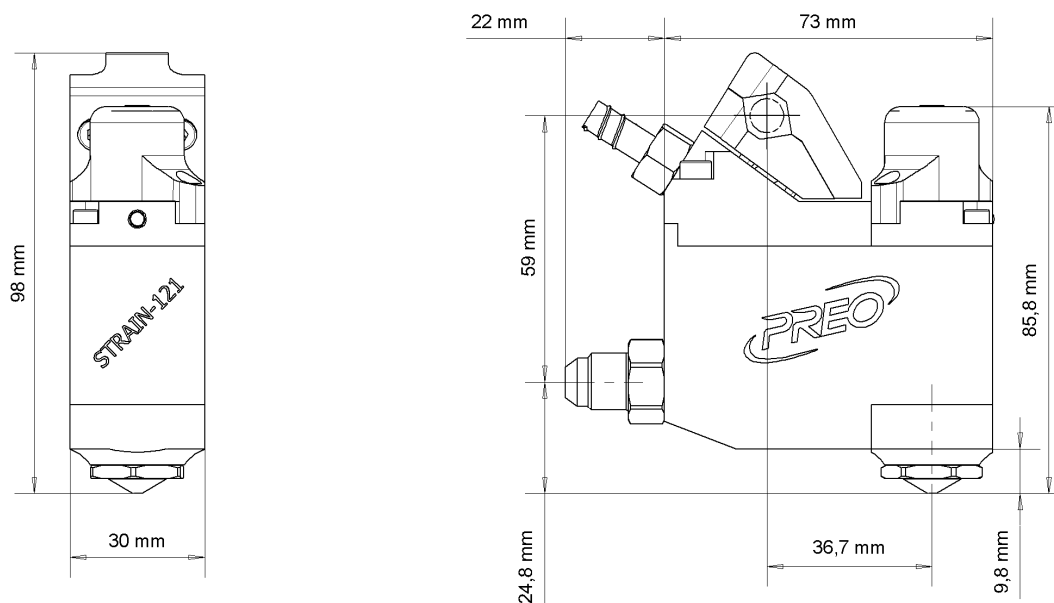

STRAIN 121 - GENERAL SPECIFICATIONS

WEIGHT	900 g
FASTENING	fixing clamp with hole \varnothing mm 10 - 12
ADHESIVE TYPOLOGY AND VISCOSITY	Hot Melt up to 5,000 mPas
OPERATING TEMPERATURE RANGE	50°C - 200°C
ACCURACY	$\pm 1^\circ\text{C}$
TEMPERATURE CONTROL METHOD	cartridge heater element
NOZZLES	1 way (0,25 - 0,30 - 0,40 mm)
CYCLE SPEED	1 ms
MAXIMUM WORKING PRESSURE	55 bar

STRAIN 121 - ELECTRICAL SPECIFICATIONS

VOLTAGE	230 VAC \approx 50 Hz single-phase
MAXIMUM SYSTEM POWER CAPACITY	160 Watt - 0,7 Amps
COIL VOLTAGE	24 V DC

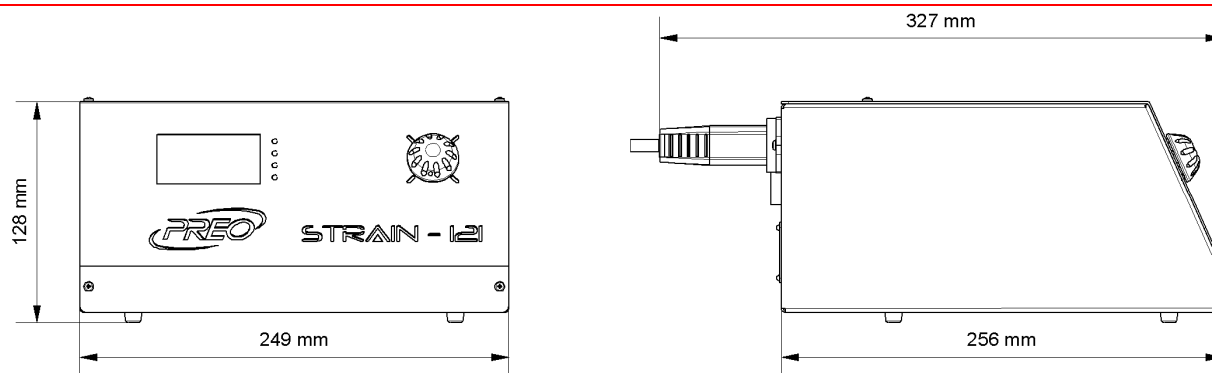

STRAIN DRIVER - GENERAL SPECIFICATIONS

NUMBER OF PROGRAMMABLE CHANNELS	up to 6
POWER SUPPLY	230 VAC \approx 50 Hz monofase
MAXIMUM GUN POWER RATING	200 Watt
INPUT LINE FUSES	6,30 A
OUTPUT LINE FUSES	4,00 A
INPUTS	NPN - PNP source 24 V DC
PROTECTIONS	short circuit, earth leakage, voltage
PROTECTION CLASS	IP30

© Copyright 2011 PREO SRL - All rights reserved - Subject to change without advanced notice - Printed in Italy - Edition EN-507 STRAIN 121 - 14/09/2011

PREO S.r.l.

Via Alessandro Volta, 7 • 20094 Corsico (MI) • Italia
 tel. (+39) 02 48601260 • fax (+39) 02 4503323
 www.preo.it • italia@preo.it • world@preo.it

Distributed in
Australia by:



Contact
 02 9645 3900
 info@epacproductions.com.au