



AZUR™ PUMP 52C225

Equipment references

64350225130000 - 64350225131101

64350225135101 - 64350225135111

64350225131115-64350225131175 - 64350225134115

User Manual 582108110

2021-03-10

Index G

Translation of the original instructions

SAMES KREMLIN SAS



13 Chemin de Malacher
38240 Meylan



www.sames-kremlin.com



33 (0)4 76 41 60 60

Any communication or reproduction of this document, in any form whatsoever, and any exploitation or communication of its contents is prohibited, except with the express written consent of **SAMES KREMLIN**. The descriptions and features contained in this document are subject to change without notice.

© **SAMES KREMLIN** 2019

Contents

Evolution table of the document	6
Guarantee	7
1 DECLARATION OF INCORPORATION OF PARTLY COMPLETED MACHINERY	8
2 EU DECLARATION OF CONFORMITY	13
3 SAFETY INSTRUCTIONS	15
3.1 PERSONAL SAFETY.....	15
Overview.....	15
Meaning of the pictograms.....	16
Security devices	17
Danger of Pressure	17
Injection hazards.....	18
Fire hazards, explosion, electric arc, static electricity.....	18
Hazards of toxic products	19
3.2 INTEGRITY OF THE MATERIAL	20
Material recommendations	20
Products implemented	24
4 ENVIRONMENT	25
5 PRESENTATION OF THE MATERIAL.....	27
5.1 COMPLETE SYSTEM	27
5.1.1 GENERIC PRESENTATION VISUAL	27
5.1.2 TABLE OF AZUR™ AIRLESS® PUMP AND PACKAGE CODES.....	28
5.1.3 VISUALS OF THE PROPOSED CONFIGURATION	29
Context of use.....	30
5.2 DESCRIPTION OF THE MAIN ELEMENTS OF THE SYSTEM	31
Pump 52C225.....	31
Motor 146371000 7000 Stroke 120.....	32
Seals kits fluid section C225.....	35
Criteria for choosing a seals kit.....	36
6 IDENTIFICATION.....	37
6.1 DESCRIPTION OF THE LABEL MARKING	37
7 PRINCIPLE OF CODIFICATION	39
7.1 PUMP CODIFICATION	39
7.2 CODIFICATION PACKS.....	40
8 EQUIPMENT PLANS.....	41
Pump 52C225.....	41
Wall mounted pump.....	42
Pump 52C225 + Cart	43
Pump 52C225 + Cart + Hopper	44
Fluid section C225.....	45
Motor 7000 Stroke 120.....	46
Air supply	47
Filter.....	48
Pump priming kit	49

Hopper	50
9 TECHNICAL SPECIFICATIONS AND OPERATING PRINCIPLES	51
9.1 TECHNICAL CHARACTERISTICS	51
9.2 PRINCIPLE OF OPERATION	54
10 INSTALLATION	56
Connections subsets	56
Connection to compressed air supply.....	57
10.1 STORAGE	58
10.2 HANDLING	58
11 COMMISSIONING.....	59
12 USE OF EQUIPMENT.....	60
12.1 USER SETTINGS	60
12.2 SAFETY IN PRODUCTION	60
12.3 RECOMMENDED RANGE OF USE	61
12.4 DIAGNOSTIC HELP / TROUBLESHOOTING GUIDE	62
12.5 POSSIBLE SYMPTOMS OF FAULTS / CAUSES OF FAULTS / REMEDY TO BE APPLIED - FAST OPERATION	64
Possible symptoms of faults / Causes / Remedies Fluid section part	64
Possible symptoms of faults / Causes / Remedies Motor part	66
13 MAINTENANCE	67
13.1 PREVENTIVE MAINTENANCE PLAN	67
Fluid section part	67
Motor part	69
13.2 PREVENTIVE MAINTENANCE	70
14 DISASSEMBLY/RE-ASSEMBLY OF THE 7000 MOTOR.....	71
14.1 DISASSEMBLY.....	71
Disassembly of the grounding cable	71
Preliminary operations	72
14.2 DISCONNECT THE MOTOR AND THE FLUID SECTION	77
14.3 REASSEMBLY.....	119
15 PNEUMATIC WIRING.....	164
Count cycles pneumatic.....	164
Fit the regulator.....	165
Direct air control.....	166
Indirect air control	167
16 FILTER	168
Install filter.....	168
Orientation of the product output.....	169
Connecting a second gun.....	170
Reversing the direction of the tank	171
17 OPERATIONS DISMANTLING / REASSEMBLING THE C225 FLUID SECTION	173
17.1 DESASSEMBLY.....	175
Change the upper seals (8 chevrons + PTFE O-ring):	175
Clean and / or replace the ball + carbide seat with rod option	182
Cleaning the carbide seat and changing the seal.....	183

17.2	REASSEMBLY.....	197
18	INSTALLATION OF THE WALL PUMP	211
19	SPARE PARTS	212
19.1	MOTOR, MODEL 7000 STROKE 120.....	212
19.2	FLUID SECTION, MODEL C225	218
	Repair kit.....	220
	Fluid section seal kit # 144 050 303	221
	Fluid section seal kit # 144 050 304	222
	Fluid section seal kit # 144 050 305	223
19.3	SPARE PARTS - PRODUCT FILTER 3/4 ", MODEL 500 BAR / 7252 PSI.....	224
	Option.....	226
	Accessories	228
	Hoses codification.....	236
	Hoses 350 bar / 5076 psi	237
	Hoses 500 bar / 7252 psi	238

Evolution table of the document

Recording revisions				
Editor	Object	Revision	Date	Modified by
	AIRLESS pump	A - Draft - beta test	Week 21/2019	N Plantard
	AIRLESS pump	B	Week 09/2020	N Plantard
	AIRLESS pump	C	Week 09/2020	N Plantard
	AIRLESS pump	D	Week 20/2020	N Plantard
	AIRLESS pump	E	Week 30/2020	N Plantard
			Week 32/2020	E DUMONT
	AIRLESS pump	F	Week 38/2020	N Plantard
	AIRLESS pump	G	Week 08/2021	E DUMONT

Dear customer, you have just purchased your new equipment and we thank you for it.

We have taken the utmost care, from design to manufacture, so that this equipment gives you complete satisfaction.

For a good use and an optimal availability, we invite you to read this manual carefully before using your equipment.

Guarantee

We reserve the right to make any changes or improvements even after receipt of an order without being able to attribute a non-compliance to the descriptions contained in the instruction manuals and selection guides.

Our equipment is checked and tested in our workshops before shipment.

To be valid, any complaint concerning a material will have to be formulated to us in writing within 10 days of the delivery.

SAMES KREMLIN equipment, equipped with its original identification plates, has a one-year warranty or 1800H of operation (first term reached) from the date of ex-factory against any defect of material or defect of it is up to us to see and appreciate.

The warranty excludes wear parts, deterioration or wear resulting from abnormal or unscheduled use by SAMES KREMLIN, failure to observe instructions for proper operation or lack of maintenance.

The warranty is limited to the repair or exchange of parts returned to our factory and recognized as defective by us and does not cover the listed wear parts or not.

Any costs resulting from an operating outage can not be charged to us. The costs of return to our workshops are the responsibility of the customer.

An intervention can be carried out on site at the customer's request.

In this case, the transportation and accommodation costs of the technician (s) will remain the responsibility of the applicant.

Any changes made to our equipment without our consent will void the warranty.

Our guarantee is limited to that of the suppliers of materials which enter in the composition of our sets.

1 Declaration of incorporation of partly completed machinery

The manufacturer : SAMES KREMLIN with assets of 12 720 000 Euros

Head office : 13, chemin de Malacher - 38 240 -
MEYLAN - FRANCE

Tel. 33 (0)4 76 41 60 60

Herewith declares that the sub-assembly Pump 52C225 with part numbers :

- 3.52225.3.1.7.15.2.5
- 3.52225.3.1.1.15.2.5
- 3.52225.3.4.3.15.2.5

Was carried out by complying with the essential rules of safety and health.

This declaration is present in the 52C225 pump package.



<p style="text-align: center;">FR</p> <p><u>Pour une utilisation sure, il est de votre responsabilité de :</u> D'installer, d'utiliser, d'entretenir et de réparer l'équipement conformément aux préconisations de SAMES KREMLIN ainsi qu'aux réglementations nationales et/ou locales, Vous assurez que les utilisateurs de cet équipement ont été formés, ont parfaitement compris les règles de sécurité et qu'ils les appliquent.</p>	<p style="text-align: center;">UK</p> <p><u>To ensure safe use of the machinery, it is your responsibility to:</u> Install, use, maintain and repair the machinery in accordance with SAMES KREMLIN's recommendations and national and/or local regulations, Make sure that the users of the machinery have received proper training and that they have perfectly understood the safety rules and apply them.</p>	<p style="text-align: center;">DE</p> <p><u>Eine sichere Nutzung setzt voraus, dass Sie:</u> die Anlage im Einklang mit den Empfehlungen von SAMES KREMLIN sowie mit den nationalen und/oder lokalen Bestimmungen installieren, verwenden, warten und reparieren, sich vergewissern, dass die Nutzer dieser Anlage angemessen geschult wurden, die Sicherheitsbestimmungen verstanden haben und sie anwenden.</p>
<p style="text-align: center;">ES</p> <p><u>Para una utilización segura, será de su responsabilidad:</u> instalar, utilizar, efectuar el mantenimiento y reparar el equipo con arreglo a las recomendaciones de SAMES KREMLIN y a la normativa nacional y/o local, cerciorarse de que los usuarios de este equipo han recibido la formación necesaria, han entendido perfectamente las normas de seguridad y las aplican.</p>	<p style="text-align: center;">IT</p> <p><u>Per un uso sicuro, vi invitiamo a:</u> installare, utilizzare, mantenere e riparare l'apparecchio rispettando le raccomandazioni di SAMES KREMLIN, nonché le normative nazionali e/o locali, accertarvi che gli utilizzatori dell'apparecchio abbiano ricevuto adeguata formazione, abbiano perfettamente compreso le regole di sicurezza e le applichino.</p>	<p style="text-align: center;">PT</p> <p><u>Para uma utilização segura, é da sua responsabilidade:</u> Proceder à instalação, utilização, manutenção e reparação do equipamento de acordo com as preconizações de SAMES KREMLIN, bem como com outros regulamentos nacionais e/ou locais aplicáveis, Assegurar-se que os utilizadores do equipamento foram devidamente capacitados, compreenderam perfeitamente e aplicam as devidas regras de segurança.</p>
<p style="text-align: center;">NL</p> <p><u>Voor een veilig gebruik dient u:</u> het apparaat te installeren, gebruiken, onderhouden en repareren volgens de door SAMES KREMLIN gegeven aanbevelingen en overeenkomstig de nationale en/of plaatselijke reglementeringen, zeker te stellen dat de gebruikers van dit apparaat zijn opgeleid, de veiligheidsregels perfect hebben begrepen en dat zij die ook toepassen.</p>	<p style="text-align: center;">SE</p> <p><u>För en säker användning av utrustningen ansvarar ni för följande:</u> Installera, använd, underhåll och reparera utrustningen enligt anvisningarna från SAMES KREMLIN och enligt nationella och/eller lokala bestämmelser. Försäkra er om att användare av denna utrustning erhållit utbildning, till fullo förstått säkerhetsföreskrifterna och tillämpar dem.</p>	<p style="text-align: center;">FI</p> <p><u>Käytön turvallisuuden varmistamiseksi velvollisuutesi on:</u> Noudattaa laitteiston asennuksessa, käytössä, kunnossapidossa ja huollossa SAMES KREMLIN in suosituksia sekä kansallisia ja/tai paikallisia määräyksiä, Varmistaa, että laitteiston käyttäjät ovat koulutettuja ja ymmärtävät täysin turvallisuusmääräykset ja miten niitä sovelletaan.</p>
<p style="text-align: center;">PL</p> <p><u>Dla zapewnienia bezpiecznego użytkowania na użytkownika spoczywa obowiązek:</u> Instalowania, użytkowania, konserwacji i naprawy urządzenia zgodnie z zaleceniami firmy SAMES KREMLIN oraz z przepisami miejscowymi, Upewnienia, że wszyscy przeszkoleni użytkownicy urządzenia zrozumieli zasady bezpieczeństwa i stosują się do nich.</p>	<p style="text-align: center;">CS</p> <p><u>Pro bezpečné používání jste povinni:</u> Nainstalovat, používat, udržovat a opravovat zařízení v souladu s pokyny firmy SAMES KREMLIN a s národními a/nebo místními legislativními předpisy, Ujistit se, že uživatelé tohoto zařízení byli vyškoleni, že dokonale pochopili bezpečnostní pravidla a že je dodržují.</p>	<p style="text-align: center;">SL</p> <p><u>Za varno uporabo ste dolžni:</u> inštalirati, uporabljati, vzdrževati in popravljati opremo po določilih SAMES KREMLIN in v skladu z veljavnimi nacionalnimi in/ali lokalnimi predpisi, poskrbeti, da so uporabniki te opreme ustrezno usposobljeni, poznajo varnostne predpise in da jih upoštevajo.</p>
<p style="text-align: center;">SK</p> <p><u>V záujme bezpečného je vašou povinnosťou:</u> nainštalovať, používať, udržiavať a opravovať zariadenie v súlade s odporúčaniami spoločnosti SAMES KREMLIN a národnými a/alebo miestnymi predpismi, uistiť sa, že používatelia tohto zariadenia boli zaškolení, riadne porozumeli pravidlám bezpečnosti a používajú ich.</p>	<p style="text-align: center;">HU</p> <p><u>A biztonságos használat érdekében az Ön felelőssége, hogy:</u> a berendezést a SAMES KREMLIN ajánlásainak valamint a nemzeti és/vagy helyi szabályozásoknak megfelelően helyezze üzembe, használja, tartsa karban és javítsa, megbizonyosodjon róla, hogy a berendezés felhasználói képzettek, tökéletesen megértették és alkalmazzák a biztonsági előírásokat.</p>	<p style="text-align: center;">RO</p> <p><u>Pentru o utilizare sigură, este responsabilitatea dvs. să:</u> Instalați, utilizați, întrețineți și reparați echipamentul conform instrucțiunilor SAMES KREMLIN precum și reglementărilor naționale și/sau locale, Vă asigurați că utilizatorii acestei echipament au fost instruiți, au înțeles perfect regulile de securitate și le aplică integral.</p>

Déclaration(s) de conformité au verso de ce document / Declaration(s) of conformity at the back of this document / Konformitätserklärung(en) auf der Rückseite Unterlage / Declaración (es) de conformidad en el reverso de este documento / Dichiarazione/i di conformità sul retro del presente documento / Declaração(ões) de conformidade no verso do documento / Conformiteitsverklaring(en) op de keerzijde van dit document / Försäkran om överensstämmelse på omstående sida av detta dokument / Vaatimustenmukaisuusvakuutukset tämän asiakirjan kääntöpuolella / Deklaracja(e) zgodności na odwrocie dokumentu / Prohlášení o shodě se nachází/nacházejí na zadní straně tohoto dokumentu / Deklaracija(e) o skladnosti na hrbtni strani tega dokumenta / Vyhlásenie/-a o zhode sa nachádzajú na zadnej strane dokumentu / A dokumentum hátlapján szereplő megfelelőségi nyilatkoz(ok) / Declarații de conformitate pe versoul acestui document



DECLARATION D'INCORPORATION
DECLARATION OF INCORPORATION
EINBAUERKLÄRUNG
DECLARACIÓN DE INCORPORACIÓN
DICHIARAZIONE DI INCORPORAZIONE
DECLARAÇÃO DE INCORPORAÇÃO
INBOUWVERKLARING BETREFFENDE
FÖRSÄKRAN FÖR INBYGGNAD
PUOLIVALMISTEIDEN LIITTÄMISVAKUUTUS
DEKLARACJA WŁĄCZENIA
PROHLÁŠENÍ O ZABUDOVÁNÍ
DEKLARACIJA O VGRADNJI
VYHLÁSENIE O ZAČLENENÍ
BEÉPÍTÉSI NYILATKOZAT
DECLARAȚIE DE ÎNCORPORARE

Le fabricant / The manufacturer / Der Hersteller / El fabricante / Il produttore / O fabricante / De fabrikant / Tillverkare / Valmistaja / Producent / Výrobce / Proizvajalec / Výrobca / Gyártó / Fabricantul:	SAMES KREMLIN SAS 13, chemin de Malacher 38 240 - MEYLAN - FRANCE Tél. : 33 (0)4 76 41 60 60
--	--

Déclare que sur la quasi-machine désignée ci-après / Herewith declares that the following partly completed machinery :

POMPE / PUMP
PUMPE / BOMBA

AZUR™ 52C225

Ont été appliquées les exigences essentielles de santé et de sécurité de la directive Machines 2006/42/CE ci-dessous / The essential health and safety requirements below of the Directive 2006/42/CE on Machinery have been applied

1.1	Généralités / General remarks
1.1.2	Principes d'intégration de sécurité / Principles of safety integration
1.1.3	Matériaux et produits / Materials and products
1.1.5	Conception de la machine en vue de sa manutention / Design of machinery to facilitate its handling
1.2	Systèmes de commande / Control systems
1.2.2	Organes de service / Control devices
1.2.3	Mise en marche / Starting
1.2.4	Arrêt / Stopping
1.2.4.1	Arrêt normal / Normal stop
1.2.4.3	Arrêt d'urgence / Emergency stop
1.2.6	Défaillance de l'alimentation en énergie / Failure of the power supply
1.3	Mesures de protection contre les risques mécaniques / Protection against mechanical hazards
1.3.1	Risque de perte de stabilité / Risk of loss of stability
1.3.2	Risque de rupture en service / Risk of break-up during operation
1.3.3	Risques dûs aux chutes, aux éjections d'objets / Risks due to falling or ejected objects
1.3.4	Risques dûs aux surfaces, aux arêtes ou aux angles / Risks due to surfaces, edges or angles
1.3.6	Risques dûs aux variations des conditions de fonctionnement / Risks related to variations in operating conditions
1.3.7	Risques liés aux éléments mobiles / Risks related to moving parts
1.3.9	Risques dûs aux mouvements non commandés / Risks of uncontrolled movements
1.4	Caractéristiques requises pour les protecteurs et les dispositifs de protection / Required characteristics of guards and protective device
1.4.1	Exigences de portée générale / General requirements
1.4.2	Exigences particulières pour les protecteurs / Special requirements for guards
1.4.2.1	Protecteurs fixes / Fixed guards

1.5	Risques dûs à d'autres dangers / Risks due to other hazards
1.5.2	Electricité statique / Static electricity
1.5.3	Alimentation en énergie autre qu'électrique / Energy supply other than electricity
1.5.4	Erreurs de montage / Errors of fitting
1.5.5	Températures extrêmes / Extreme temperatures
1.5.6	Incendie / Fire
1.5.7	Explosion
1.5.8	Bruit / Noise
1.6	Entretien / Maintenance
1.6.1	Entretien de la machine / Machinery maintenance
1.6.2	Accès aux postes de travail ou aux points d'intervention / Access to operating positions and servicing points
1.6.3	Séparation de la machine de ses sources d'énergie / Isolation of energy sources
1.6.4	Intervention de l'opérateur / Operator intervention
1.7	Informations / Information
1.7.1	Informations et avertissements sur la machine / Information and warnings on the machinery
1.7.2	Avertissement sur les risques résiduels / Warning of residual risks

La documentation technique pertinente a été constituée conformément à l'annexe VII, partie B / The relevant technical documentation was compiled as specified in annex VII, part B.

Cette quasi-machine est également conforme aux dispositions suivantes / That partly completed machinery is also in conformity with the provisions of

<p>Directive ATEX / ATEX Directive / ATEX Richtlinie / Directiva ATEX / Direttiva ATEX / Diretiva ATEX / ATEX-Richtlijn / ATEX-direktivet / ATEX-direktivi / Dyrektywa ATEX / Směrnice ATEX / Direktiva ATEX / Smernica ATEX / ATEX-irányelv</p> <p style="text-align: center;"> II2G Ex h IIA T2...T4 Gb X</p> <p>EN ISO 80079-36 Juin 2016 EN ISO 80079-37 Juin 2016 EN 1127-1 Août 2019 EN 1953 Octobre 2013</p> <p>Ex h=> Protection par sécurité de construction (c) / Protection by constructional safety (c) / Schutz durch konstruktive Sicherheit (c) / Protección por seguridad constructiva (c) / Protezione per sicurezza costruttiva (c) / Protecção por segurança construtiva (c) / Bescherming door constructieveiligheid (c) / Säker konstruktion (c) / Suojaus rakenteellisella turvallisudella (c) / Zabezpečenie za pomocou bezpečnosti konštrukčného (c) / Ochrana bezpečnou konstrukci (c) / Zaščita s konstrukcijsko varnostjo (c) / Ochrana bezpečnou konštrukciou (c) / Szerkezetbiztonsági védelem (c) / Protecție prin securitate constructivă (c)</p> <p style="text-align: center;">INERIS 0080 - 60550 Verneuil-en-Halatte – France – INERIS-EQEN 035726/20</p>	<p>2014/34/UE</p>
---	--------------------------

Cette quasi-machine ne doit pas être mise en service avant que la machine finale dans laquelle elle doit être incorporée ait été déclarée conforme à la directive Machines 2006/42/CE / This partly completed machinery must not be put into service until the final machinery in which it is to be incorporated has been declared in conformity with Directive 2006/42/CE on Machinery.

La société SAMES KREMLIN est autorisée à constituer la documentation technique / SAMES KREMLIN is allowed to compile the technical documentation.

SAMES KREMLIN s'engage à transmettre, à la suite d'une demande dûment motivée des autorités nationales, les informations pertinentes concernant la quasi-machine sous la forme la plus appropriée / SAMES KREMLIN undertakes to transmit, in response to a reasoned request by the national authorities, relevant information on the partly completed machinery in the most appropriate form.



Hervé WALTER

Directeur Recherche & Développement / Research & Development Director / Direktor für Forschung & Entwicklung / Director de Investigación y Desarrollo / Direttore Ricerca e sviluppo / Diretor de Pesquisa e desenvolvimento / Manager Onderzoek en Ontwikkeling / Direktör för Forskning och Utveckling / Johtaja tutkimus ja kehitys / Dyrektor ds. Badań i rozwoju / Ředitel výzkumu a vývoje / Direktor za raziskave in razvoj / Riaditeľ pre výskum a vývoj / Kutatási és Fejlesztési Igazgató / Director de cercetare și Dezvoltare

Fait à Meylan, le / Established in Meylan, on / Geschehen zu Meylan, am / En Meylan, a / Redatto a Meylan, / Vastgesteld te Meylan, / Utformat i Meylan, den / Meylan, Ranska, / Sporządzono w Meylan, dnia / Meylan, dnia / V Meylanu, / V Meylan dňa / Kelt Meylanban, / Întocmită la Meylan, pe data de 23/02/2021 – 02/23/2021

2 EU DECLARATION OF CONFORMITY



DECLARATION UE DE CONFORMITE
UE DECLARATION OF CONFORMITY
EU- KONFORMITÄT SERKLÄRUNG
DECLARACIÓN UE DE CONFORMIDAD
DICHIARAZIONE DI CONFORMITÀ UE
DECLARAÇÃO UE DE CONFORMIDADE
EU-CONFORMITEITSVERKLARING
EU-FÖRSÄKRAN OM ÖVERENSSTÄMMELSE
EU- VAATIMUKSEN MUKAISUUSVAKUUTUS
DEKLARACJA ZGODNOŚCI UE
EU PROHLÁŠENÍ O SHODĚ
IZJAVA EU O SKLADNOSTI
VYHLÁSENIE O ZHODE
EU-MEGFELELŐSÉGI NYILATKOZAT
DECLARAȚIA DE CONFORMITATE UE

Le fabricant / The manufacturer / Der Hersteller / El fabricante / Il produttore / O fabricante / De fabrikant / Tillverkare / Valmistaja / Producent / Výrobce / Proizvajalec / Výrobca / Gyártó / Fabricantul:	SAMES KREMLIN SAS 13, chemin de Malacher 38 240 - MEYLAN - FRANCE Tél. : 33 (0)4 76 41 60 60
--	--

Déclare que sur la quasi-machine désignée ci-après / Herewith declares that the following partly completed machinery :

POMPE / PUMP
PUMPE / BOMBA

AZUR™ 52C225

Est conforme à la législation d'harmonisation de l'Union applicable suivante / Is in conformity with the relevant Union harmonisation legislation / Erfüllt die einschlägigen Harmonisierungsrechtsvorschriften der Union / es conforme con la legislación de armonización pertinente de la Unión / è conforme alla pertinente normativa di armonizzazione dell'Unione / in overeenstemming met de desbetreffende harmonisatiewetgeving van de Unie / med den relevanta harmoniserade unionslagstiftningen / on asiaa koskevan unionin yhdenmukaistamislainsäädännön vaatimusten mukainen / jest zgodny z odnośnymi wymaganiami unijnego prawodawstwa harmonizacyjnego / Shoduje se s následující příslušnou evropskou harmonizační legislativou / V skladu s harmonizirano zakonodajo Unije / Je v súlade s uplatniteľnými harmonizačnými právnymi predpismi EÚ / Megfelel a következő alkalmazandó uniós harmonizációs szabályozásnak / Este conform cu legislația aplicabilă de armonizare de mai jos

Directive ATEX / ATEX Directive / ATEX Richtlinie / Directiva ATEX / Direttiva ATEX / Diretiva ATEX / ATEX-Richtlijn / ATEX-direktivet / ATEX-direktivi / Dyrektywa ATEX / Směrnice ATEX / Direktiva ATEX / Smernica ATEX / ATEX-irányelv  II2G Ex h IIA T2...T4 Gb X EN ISO 80079-36 Juin 2016 EN ISO 80079-37 Juin 2016 EN 1127-1 Août 2019 EN 1953 Octobre 2013 Ex h=> Protection par sécurité de construction (c) / Protection by constructional safety (c) / Schutz durch konstruktive Sicherheit (c) / Protección por seguridad constructiva (c) / Protezione per sicurezza costruttiva (c) / Protecção por segurança construtiva (c) / Bescherming door constructieveiligheid (c) / Säker konstruktion (c) / Suojaus rakenteellisella turvallisudella (c) / Zabezpieczenie za pomocą bezpieczeństwa konstrukcyjnego (c) / Ochrana bezpečnou konstrukci (c) / Zaščita s konstrukcijsko varnostjo (c) / Ochrana bezpečnou konštrukciou (c) / Szerkezetbiztonsági védelem (c) / Protecție prin securitate constructivă (c) INERIS 0080 - 60550 Verneuil-en-Halatte – France – INERIS-EQEN 035726/20	2014/34/UE
--	-------------------

La présente déclaration de conformité est établie sous la seule responsabilité du fabricant / This declaration of conformity is issued under the sole responsibility of the manufacturer / Die alleinige Verantwortung für die Ausstellung dieser Konformitätserklärung trägt der Hersteller / La presente declaración de conformidad se expide bajo la exclusiva responsabilidad del fabricante / La presente dichiarazione di conformità è rilasciata sotto la responsabilità esclusiva del fabbricante / A presente declaração de conformidade é emitida sob a exclusiva responsabilidade do fabricante / Deze conformiteitsverklaring wordt verstrekt onder volledige verantwoordelijkheid van de fabrikant / Denna försäkran om överensstämmelse utfärdas på tillverkarens eget ansvar / Tämä vaatimustenmukaisuusvakuutus on annettu valmistajan yksinomaisella vastuulla / Niniejsza deklaracja zgodności wydana zostaje na wyłączną odpowiedzialność producenta / Toto prohlášení o shodě se vydává na výhradní odpovědnost výrobce / Za izdajo te izjave o skladnosti je odgovoren izključno proizvajalec / Toto vyhlásenie o zhode sa vydáva / na vlastnú zodpovednosť výrobcu / Ezt a megfelelőségi nyilatkozatot a gyártó kizárólagos felelősége mellett adják ti / Prezenta declarație de conformitate este emisă pe răspunderea exclusivă a producătorului.



Hervé WALTER

Directeur Recherche & Développement / Research & Development Director / Direktor für Forschung & Entwicklung / Director de Investigación y Desarrollo / Direttore Ricerca e sviluppo / Diretor de Pesquisa e desenvolvimento / Manager Onderzoek en Ontwikkeling / Direktör för Forskning och Utveckling / Johtaja tutkimus ja kehitys / Dyrektor ds. Badań i rozwoju / Ředitel výzkumu a vývoje / Direktor za raziskave in razvoj / Riaditeľ pre výskum a vývoj / Kutatási és Fejlesztési Igazgató / Director de cercetare și Dezvoltare

Fait à Meylan, le / Established in Meylan, on / Geschehen zu Meylan, am / En Meylan, a / Redatto a Meylan, / Vastgesteld te Meylan, / Utformat i Meylan, den / Meylan, Ranska, / Sporządzono w Meylan, dnia / Meylan, dnia / V Meylanu, / V Meylan dňa / Kelt Meylanban, / Întocmită la Meylan, pe data de 23/02/2021 – 02/23/2021

3 Safety instructions

3.1 Personal safety

Overview



Read all operating instructions and device labels carefully before putting the equipment into service.

Personnel using this equipment must have been trained in its use.

The workshop manager must ensure that the operators have fully understood all the instructions and safety rules of this equipment and other elements and accessories of the installation.

Misuse or operation can cause serious injury. This material is for professional use only. It must be used only for the purpose for which it was intended.

Do not modify or transform the material. Parts and accessories must only be supplied or approved by SAMES KREMLIN.

The equipment must be checked periodically. Defective or worn parts must be replaced.

Never exceed the maximum working pressures of the equipment components.

Always respect the laws in force regarding security, fire, electricity of the destination country of the equipment.

Only use products or solvents that are compatible with the parts in contact with the product (see product manufacturer's technical data sheet).

Meaning of the pictograms

 <p>Danger pinching, crushin</p>	 <p>Danger moving parts</p>	 <p>Danger : high pressure</p>	 <p>Risks of product emanation</p>
 <p>Danger : hot parts or surfaces</p>	 <p>Danger : flammability risks</p>	 <p>Danger : electricity</p>	 <p>Risk of explosion</p>
 <p>Danger (user)</p>	 <p>Warning Danger</p>	 <p>Gloves required</p>	 <p>Grounding</p>
 <p>Protective helmet</p>	 <p>Hearing protection</p>	 <p>Mandatory respiratory protection</p>	 <p>Safety shoe</p>
 <p>Protective clothing</p>	 <p>Protective visor</p>	 <p>Safety glasses is mandatory</p>	 <p>Refer to the manual/instruction leaflet</p>

Security devices



Attention

- ✓ Guards (motor cover, coupling guard, housings, ...) are set up for safe use of the equipment.
- ✓ The manufacturer can not be held responsible for any bodily injury as well as failures and / or damage to the equipment resulting from the destruction, the occultation or the total or partial removal of the protectors.
- ✓ Never exceed the maximum working pressures of the equipment components.

Danger of Pressure



Safety requires that a decompressed air shutoff valve be mounted on the pump motor supply circuit to allow trapped air to escape when the supply is shut off.

Without this precaution, the residual air from the engine may cause the motor pump to operate and cause a serious accident.

Similarly, a **product purge valve** must be installed on the product circuit so that it can be purged (after shutting off engine air and decompressing it) before any intervention on the equipment. These valves should remain closed for air and open for the product during the procedure.

Injection hazards

“HIGH PRESSURE” technology requires the utmost care.

Operation can cause dangerous leaks. There is a risk of product injection into exposed parts of the body, which can lead to serious injury and the risk of amputation:

- ✓ An injection of product into the skin or other parts of the body (eyes, fingers ...) must be treated urgently by appropriate medical care.
- ✓ Do not look at the gun nozzle when it is under pressure.
- ✓ Never direct the jet to another person.
- ✓ Never attempt to stop the jet with the body (hands, fingers ...) or with rags or similar.

Fire hazards, explosion, electric arc, static electricity



Improper grounding, insufficient ventilation, open flames or sparks can cause an explosion or fire which could result in serious injury.

To avoid these risks, especially when using pumps, it is imperative:

- ✓ To connect the equipment, the parts to be treated, the cans of products and cleaners to the ground,
- ✓ To ensure good ventilation,
- ✓ Keep the work area clean and free of rags, papers, solvents,
- ✓ Do not operate electrical switches in the presence of vapors or during removal,
- ✓ Immediately stop the application in the presence of arcs,
- ✓ Store all liquids outside the work areas.
- ✓ Use products whose flash point is as high as possible to avoid any risk of formation of flammable gases and vapors (consult the product safety data sheets).
- ✓ To equip the drums with a lid to reduce the diffusion of gases and vapors in the cabin.
- ✓ It is forbidden to pump explosive materials

Hazards of toxic products

Toxic products or vapors can cause serious injury through contact with the body, in the eyes, under the skin, but also by ingestion or inhalation. It is imperative :

- ✓ To know the type of product used and the dangers it represents,
- ✓ Store the products to be used in appropriate areas,
- ✓ Contain the product used in the application in a container designed for that purpose,
- ✓ Evacuate the products in accordance with the legislation of the country where the equipment is used,
- ✓ To wear protective clothing designed for that purpose,
- ✓ Wearing goggles, hearing protectors, gloves, shoes, coveralls and masks for the respiratory tract.



Attention

The use of halogenated hydrocarbon solvents and products containing these solvents in the presence of aluminum or zinc is prohibited.

Failure to follow these instructions exposes the user to the risk of explosion resulting in serious injury or death.

3.2 Integrity of the material

Material recommendations



Protectors are put in place for safe use of the equipment.

Exemples :

- ✓ Engine hood.
- ✓ Carters.

The manufacturer can not be held responsible in case of:

- ✓ Bodily injury.
 - ✓ As well as breakdowns and / or damage to the equipment resulting from the destruction, the occultation or the total or partial withdrawal of the protectors.
-

Pump



Recommendations for pumps.

- ✓ It is essential to read the compatibilities of the motors and pumps before coupling as well as the special safety instructions.
- ✓ These instructions are on the pump instruction manuals.
- ✓ The pneumatic motor is intended to be coupled to a fluid section. Never modify the coupling system.
- ✓ Keep hands clear of moving parts.
- ✓ The parts constituting this movement must be kept clean.
- ✓ Before starting up or using the motor pump, carefully read the DECOMPRESSION PROCEDURE.
- ✓ Check that the decompression and purge air valves are working properly.
- ✓ It is forbidden to operate the pump without its protective motor cover – risk of crushing
- ✓ It is forbidden to disassemble the safety valve during the operation of the pump – check that the air regulator and pressure gauge are working once a month.
- ✓ Only use genuine SAMES KREMLIN accessories and spare parts designed to withstand the pump's operating pressures.

Booster phase of the pump

- ✓ Mandatory wearing of PPE (glasses + gloves + safety shoes).

Feeding cycle

- ✓ The booster cycle must be at a maximum of 1 bar at the gauge of the air equipment, keeping the gun open. Progressive manual mounting to the air regulator.
-

Paint phase pump and pressure gun



- ✓ Mandatory wearing of PPE during this phase of painting where the pump and the gun are under pressure.
- ✓ Do not look at the gun nozzle when it is under pressure.
- ✓ Rinse at a maximum of 1 bar at the pressure gauge of the air equipment (variable pressure depending on the length of the pipes).

Rinsing the pump



- ✓ Wearing PPE (glasses + gloves + safety shoes)
- ✓ Do not look at the gun nozzle when it is under pressure
- ✓ Rinse at a maximum of 1 bar at the pressure gauge of the air equipment (variable pressure depending on the length of the pipes).

Defusing the pump



- ✓ PPE port mandatory.

Risk of fluid section heating during defusing



- ✓ Risk of overheating of the fluid section in case of defusing.

Mass cable



- ✓ It is mandatory to connect the pump to earth. The canes are conductive

Trolley

Concerning the work and displacement of the pump on trolley on a flat floor it is forbidden to pull on the trolley and pump assembly via the pipe.

Hoses

Recommendations for hoses.

- ✓ Keep hoses away from traffic areas, moving parts and hot areas.
- ✓ Never subject product hoses to temperatures above 60 ° C or below 0 ° C.
- ✓ Do not use hoses to pull or move equipment.
- ✓ Tighten all connections and hoses and connectors before commissioning the equipment.
- ✓ Check hoses regularly, replace them if damaged.
- ✓ Never exceed the maximum operating pressure stated on the hose (PMS).
- ✓ For fitting the hoses and gun: PPE is mandatory.
- ✓ Tighten to block stop. (Pipes + Pistol)

Normal stop

To make a normal stop:

- ✓ Use the air regulator to gradually decompress the pump.

Emergency shut-off valve

- ✓ The stop valve 91458 is an emergency stop valve.
 - ✓ This valve must be within easy reach of the operator.
-

Products implemented

Given the diversity of the products implemented by the users and the impossibility of listing all the characteristics of the chemical substances, their interactions and their evolution over time SAMES KREMLIN can not be held responsible:

- ✓ The poor compatibility of materials in contact.
- ✓ inherent risks to staff and the environment.
- ✓ Wear and tear, maladjustment, malfunction of equipment or machines and the quality of the finished product.

The user will have to identify and prevent the potential dangers inherent to the implemented products such as:

- ✓ Toxic vapors.
- ✓ Fire.
- ✓ Explosions.

It will determine the risks of immediate reactions or due to repeated exposures to the staff.

SAMES KREMLIN declines any responsibility, in case of:

- ✓ Bodily or psychic injuries.
 - ✓ Direct or indirect material damage due to the use of chemical substances.
-

4 Environment

The equipment must be installed on a horizontal, stable and flat ground (eg concrete slab).

Non-moving equipment must be secured by suitable fixing devices (spit, screws, bolts, etc.) to ensure its stability during use.

To avoid risks due to static electricity, the equipment and its components must be grounded.



- ✓ **For pumping equipment** (pumps, elevators, chassis, etc.), a 2.5 mm section wire is attached to the equipment. Use this wire to connect the equipment to the general "earth". In severe environments (mechanical protection of the ground wire, vibrations, moving equipment, etc.) where damage to the grounding function is likely, the user will have to replace the wire of 2, 5 mm supplied, by a device more adapted to its environment (wire of greater section, braid of mass, fixing by lug with eyelet ...).
- ✓ Have the earth continuity checked by a qualified electrician. If earth continuity is not assured, check terminal, wire and grounding point. Never operate the equipment without solving this problem.
- ✓ The gun must be "grounded" through the fluid hose. When spraying from a gun, the fluid hose must be conductive.
- ✓ The materials to be painted must also be "grounded" by means of clamps with cables or, if they are suspended, by means of hooks which must remain permanently clean.

Note: all objects in the work area must also be grounded.

-
- ✓ **Do not store** more flammable products than necessary inside the work area.
 - ✓ These products must be stored in **approved containers** and grounded.
 - ✓ Use only grounded **metal buckets** for the use of rinse solvents.
 - ✓ **Cartons and papers are to be banned.** Indeed they are very bad conductors, even insulators.

Material marking



Each device is equipped with a sign plate with the name of the manufacturer, the reference of the device, important information for the use of the device (pressure, power, ...) and sometimes against the pictogram shown below.

The equipment is designed and manufactured with high quality materials and components that can be recycled and reused.

European Directive 2012/19 / EU applies to all devices marked with this logo (crossed out bin). Find out about the collection systems available for electrical and electronic devices.

Comply with the rules in your area and **do not dispose of old appliances with household waste.** Proper disposal of this old device will help prevent adverse effects on the environment and human health.

5 Presentation of the material

5.1 Complete system

5.1.1 Generic presentation visual

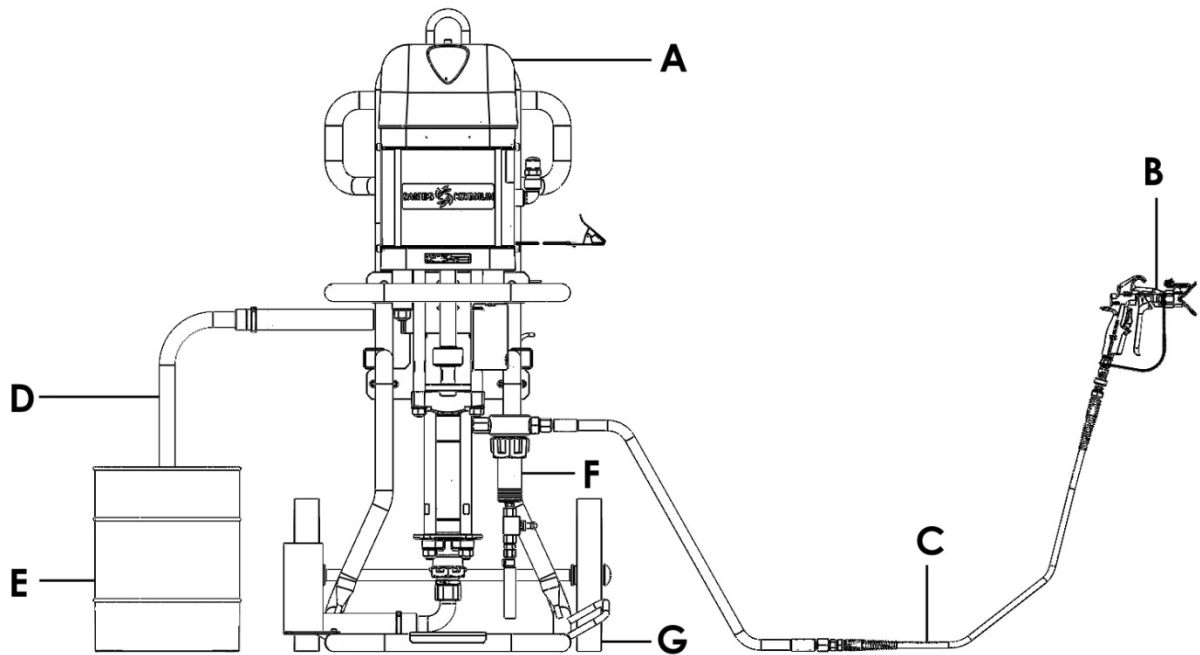

Ind	Description
A	Azur™ Pump
B	Gun
C	Hose
D	Suction rod
E	Bucket
F	Filter
G	Cart

5.1.2 Table of Azur™ Airless® pump and package codes

Part number	Working pressure (bar)	Assembling			Air regulator Fluid pressure	Suction			Output filter	TE	Sflow™ gun	Airless hose 15m 3/8 + 1.6m 1/4
		Bare	Wall mounted	Cart		Hose 600 mm	Hose 1000 mm	Gravity hopper				
64350225130000	312	X										
64350225131101	312		X		X	X						
64350225135101	312		X		X		X					
64350225135111	312		X		X		X		X			
64350225131115	312			X	X	X			X			
64350225131175	312			X	X	X				X		
64350225134115	312			X	X			X	X			
3522253171525	312			X	X	X				X	X	X
3522253111525	312			X	X	X			X		X	X
3522253411525	312			X	X			X	X		X	X

5.1.3 Visuals of the proposed configuration

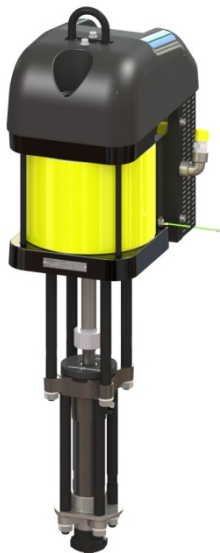

Azur™ Pump 52C225 – 64350225130000



**Wall mounted Azur™ pump 52C225 + Air supply
+ Suction rod L600 – 64350225131101**



**Wall mounted Azur™ pump 52C225 + Air
supply + Suction rod L1000 –
64350225135101**



**Wall mounted Azur™ pump 52C225+ Air supply
+ Suction rod L1000 + Filter – 64350225135111**



Wall mounted Azur™ pump 52C225 + Air supply + Cart + Suction rod L600 + Filter – 64350225131115



Azur™ Pump 52C225 + Air supply, Cart, Suction rod L600, TE assembly, Valve, Drain – 64350225131175



Azur™ Pump 52C225 + Air supply + Cart + Hopper + Filter – 64350225134115

Context of use

AZUR™AIRLESS® 52C225 pumps are designed to meet the required performance and lifetime requirements:

- ✓ Very high performance pump for maximum energy savings.
- ✓ Optimized design: simple and fast maintenance
The use of equipment is most often in the workshop or outdoors on site.

5.2 Description of the main elements of the system

Pump 52C225



Expected use

These pumps, coupled with air motors, are designed to transfer or spray different liquid or pasty products with a desired flow rate and outlet pressure.

Motor 146371000
7000 Stroke 120



Expected use

This Pneumatic motor is intended to be coupled to the fluid section systems recommended by SAMES KREMLIN in order to obtain the ratio and the expected flow rate.

Functional description

Double-acting pneumatic piston motor. Rectilinear reciprocating movement.

Adjustment

The increase of the motor supply air pressure (via the air regulator) leads to an increase of the number of pump piston returns/mn (cycles) which leads to a flow rate increase and to an outlet pressure increase of the pumped material.

AIR CONSUMPTION OF THE MOTOR	
Pressure of the motor at 6 bar / 87 psi	
Type	daN
7000	2903

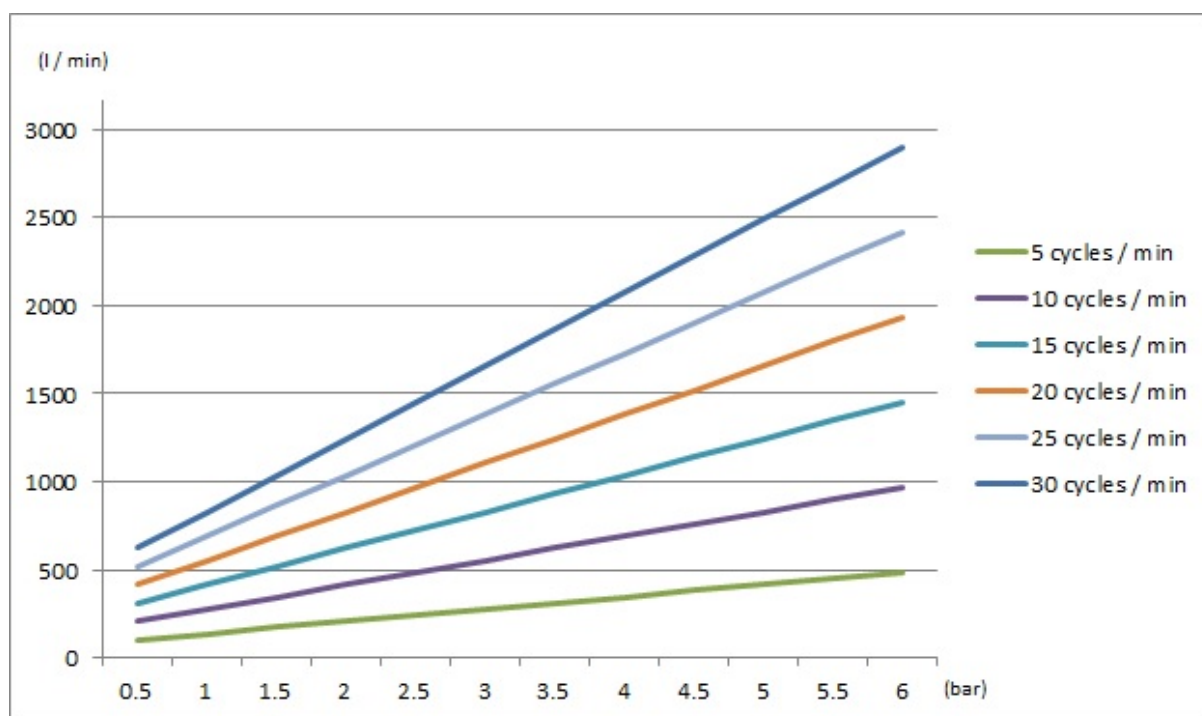

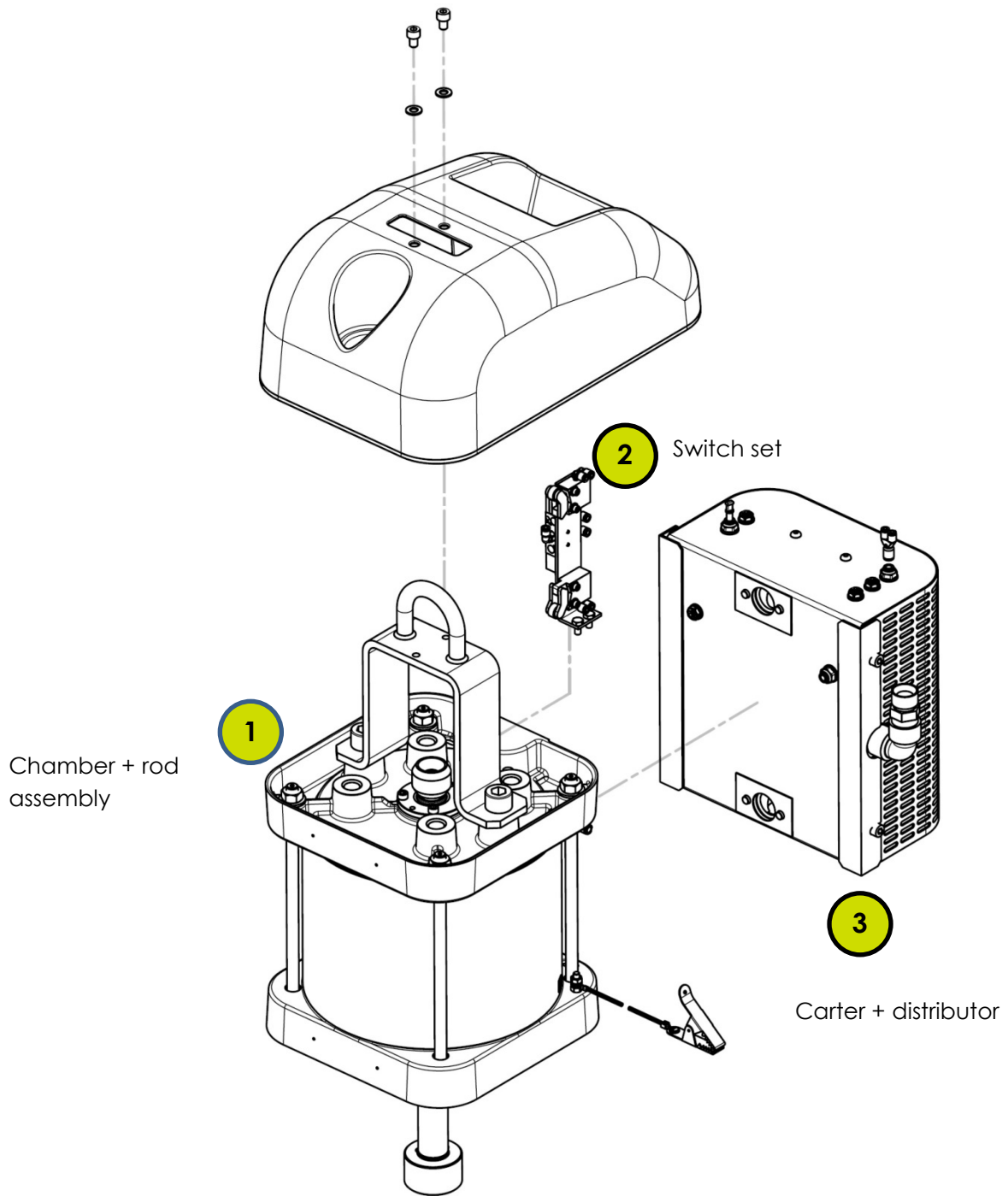

**Seals kits fluid section
C225**

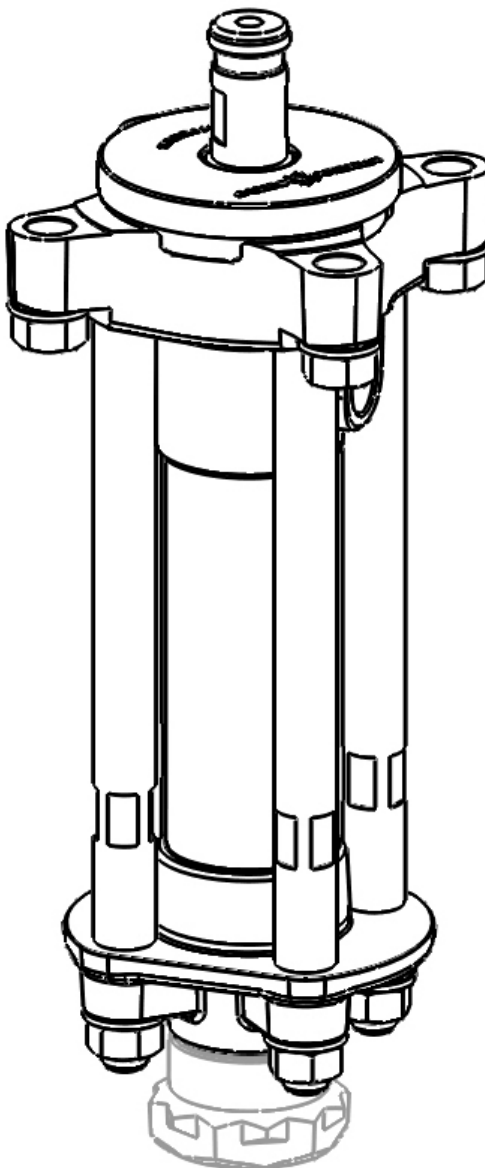

Seals kits		O-rings (statics)	Upper packing	Lower packing
144050313	UHMWPE + PTFE	PTFE	4x UHMWPE + 4x LEATHER	3x UHMWPE + 3x LEATHER
144050314	UHMWPE + LEATHER	PTFE	4x PTFE + 4x LEATHER	3x PTFE + 3x LEATHER
144050315	UHMWPE + PTFE G	PTFE	4x UHMWPE + 4x PTFE G	3x UHMWPE + 3x PTFE G

Criteria for choosing a seals kit

Seal package Choice		Selection Criterias			
#	Seal kit	Chemical Compatibility	Mechanical Resistance (abrasivity)	Temperature up to 60°C	Comment
144050313	UHMWPE / PTFE	★★	★★	★★★	Good chemical compatibility. Ideal for preximed 2K material. Not ideal for abrasive material
144050314	UHMWPE / Leather	★★	★★★★	★★	Entry offer for abrasive Solvent Based material*
144050315	UHMWPE / PTFE G	★★★	★★	★★★★	Solvent Based material. Lower the coefficient of friction and has excellent self lubricating properties. Good resistance to high temperature (up to 60°C)

(*) Please refer to chemical compatibility table

6 Identification

6.1 Description of the label marking

Principles

Paint pumps are designed to be installed in a paint booth.

This equipment complies with the following provisions:

- ✓ ATEX Directive (2014/34 / EU : II 2 G – Group II, Category 2, Gas).

This UE Declaration of Conformity is included in the packaging of the 52C225 pump.

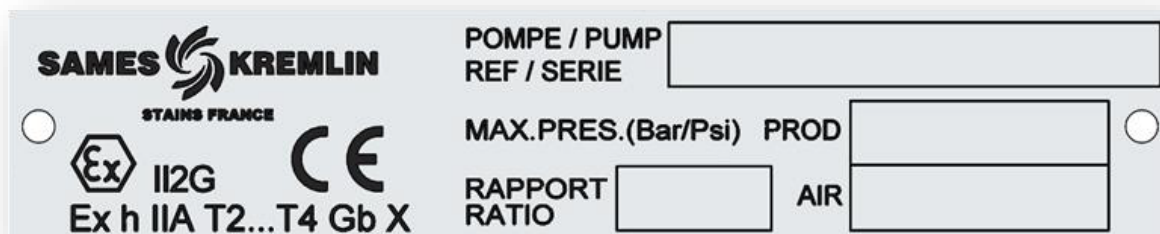

Description	
Sigle SAMES KREMLIN	Manufacturer's mark
	<p> : Use in explosive area</p> <p>II : group II 2 : category 2</p> <p>Surface material intended for an environment in which explosive atmospheres due to gases, vapors, mists are likely to occasionally occur during normal operation.</p> <p>G : gas</p>
EC	EC : European conformity
Ex h IIA T2...T4	<p>Ex Marking of conformity to European standards</p> <p>h : Mode of protection for non electrical device</p> <p>IIA : Reference gas for equipment qualification</p> <p>T2...T4 : Temperature class - Maximum surface temperature</p>
Gb	Gb : Equipment protection level (Gas zone1)
X	Special conditions apply for safe use. Refer to the requirements in the instruction manuals accompanying this product.
Pompe / Pump	Model of the pump
REF.	Pump reference
SERIES	Number given by SAMES KREMLIN . The first 2 digits indicate the year of manufacture
MAX. PRES. (BAR/PSI)	-
PROD	Maximum product pressure
AIR	Maximum air pressure
REPORT / RATIO	Pump pressure ratio

*** Temperature class**

Seals kits	Composition	Temperature class	Maximum surface temperature
144050313	UHMWPE / PTFE	T3	200°C / 392°F
144050314	UHMWPE / Leather	T4	135°C / 275°F
144050315	UHMWPE / PTFE G	T2	300°C / 572°F

7 Principle of codification

7.1 Pump codification

PUMP CODIFICATION

	X	X	X	X		X	X	X	X
Motor and hydraulic type 6435									
Fluid section 0225 0160									
Fluid section material Inox: 1									
Seal pack UHMWPE + PTFE: 3 UHMWPE + Leather: 4 UHMWPE + PTFE G: 5									
									Pump stand 0:None 1:Wall mounted 5: Heavy duty cart
									Pump Output 0: None 1: with filter SST 2: with filter SST + 2 outputs* 7: with priming kit*
									Pump control panel 0: None 1: Pump air regulator
									Pump Input 0:None 1: Suction rod ø1: 30L 2: Suction rod ø2'' 30L* 4: Hopper 5: Suction rod 200L*

*: Optional upon request, delivery time to be confirmed

7.2 Codification packs

PACK LIGHT CODIFICATION

X	X	X	X	X	X	X	X
Pack range Airless : 3							Gun type 0: None 5: SFlow™reversible tip 519
Pump selection 52225 72160							Whip end hose 0: None 1: 1m Polyamid 1/4" - 1/4 NPSM* 2: 1.6m Polyamid 1/4" - 1/4 NPSM
Seal pack UHMWPE + PTFE: 3 UHMWPE + Leather: 4 UHMWPE + PTFE G: 5							Main hose lenght 0: None 10 : 10m Polyamid 3/8" - 3/8 NPSM* 15: 15 m Polyamid 3/8" - 3/8 NPSM 30: 30 m Polyamid 3/8" - 3/8 NPSM*
Pump input None: 0 Suction rod ø1" 30L: 1 Suction rod ø2" 30L*: 2 Hopper: 4 Suction rod 200L*: 5							Pump output 0: None 1: with filter SST 2: with filter SST + 2 outputs* 7: with priming kit*

*: Optional upon request, delivery time to be confirmed

8 Equipment plans

Pump 52C225

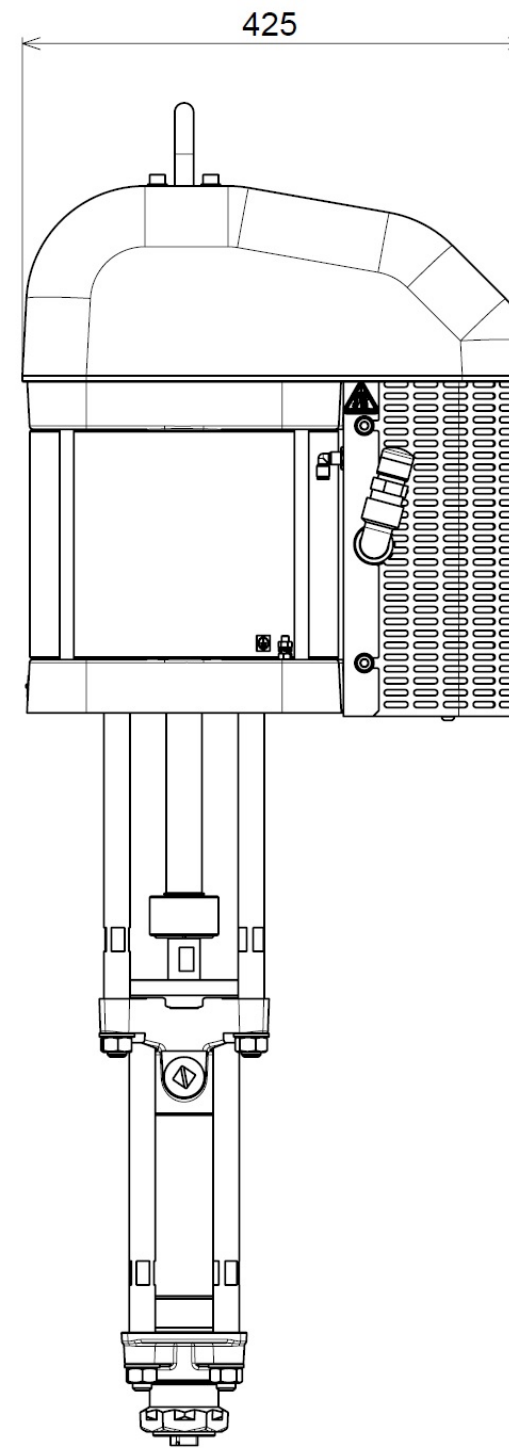
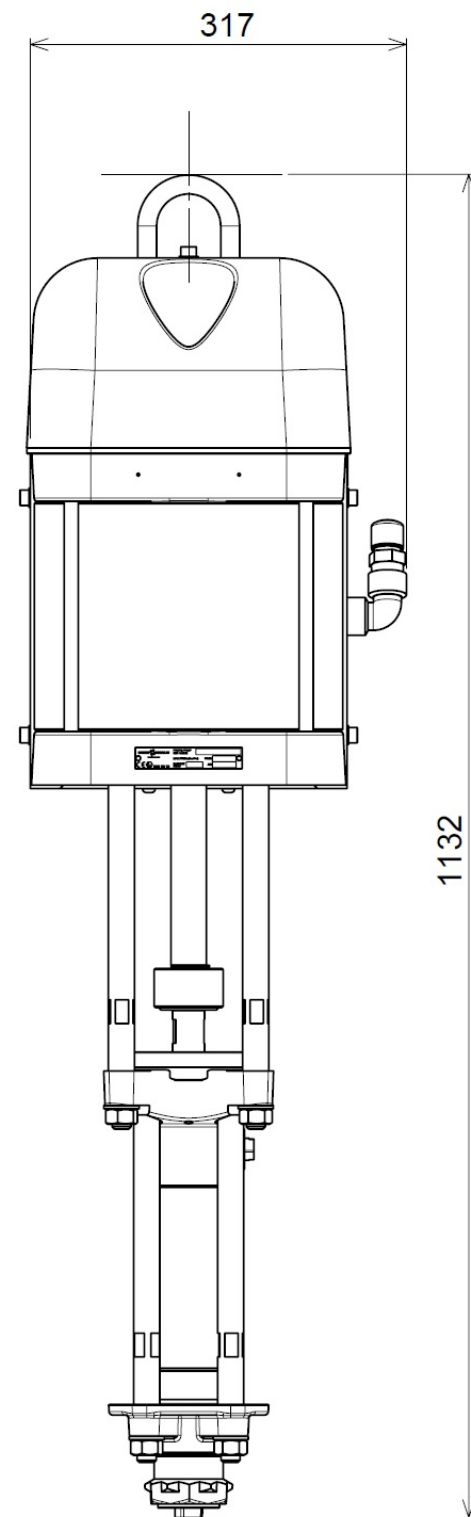
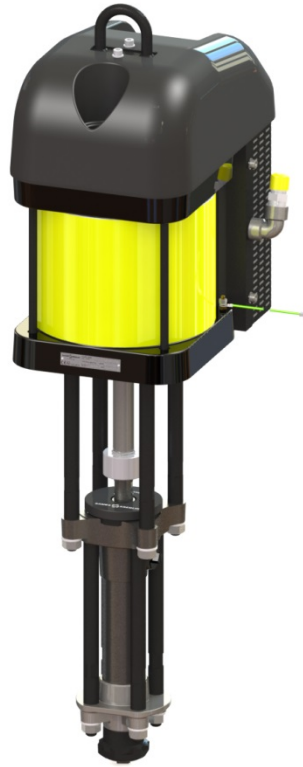

Wall mounted pump

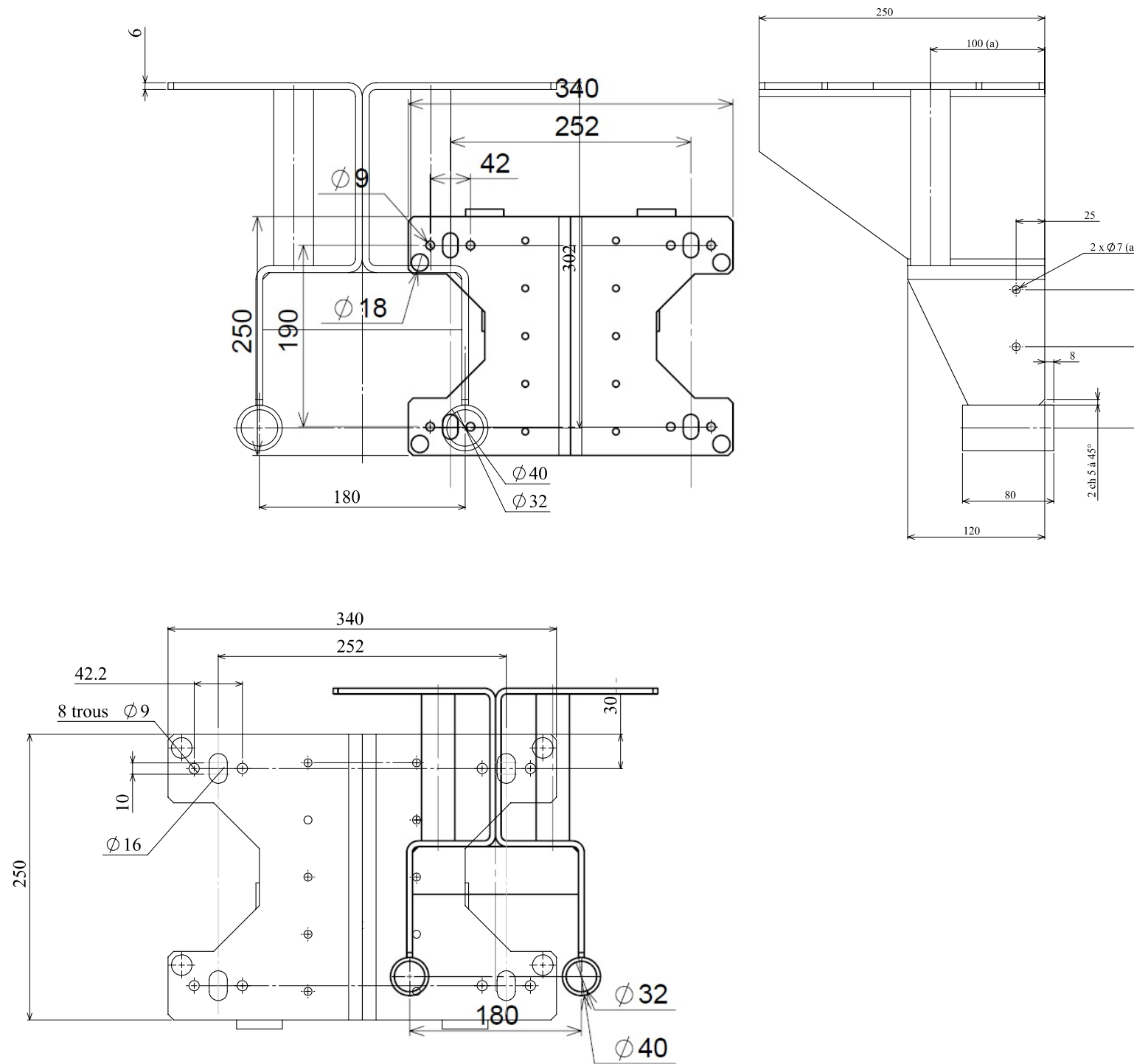
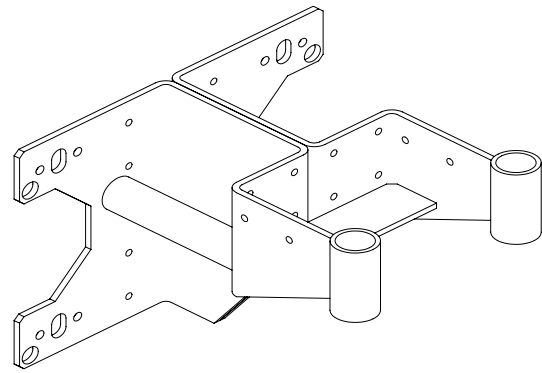

Pump 52C225 + Cart

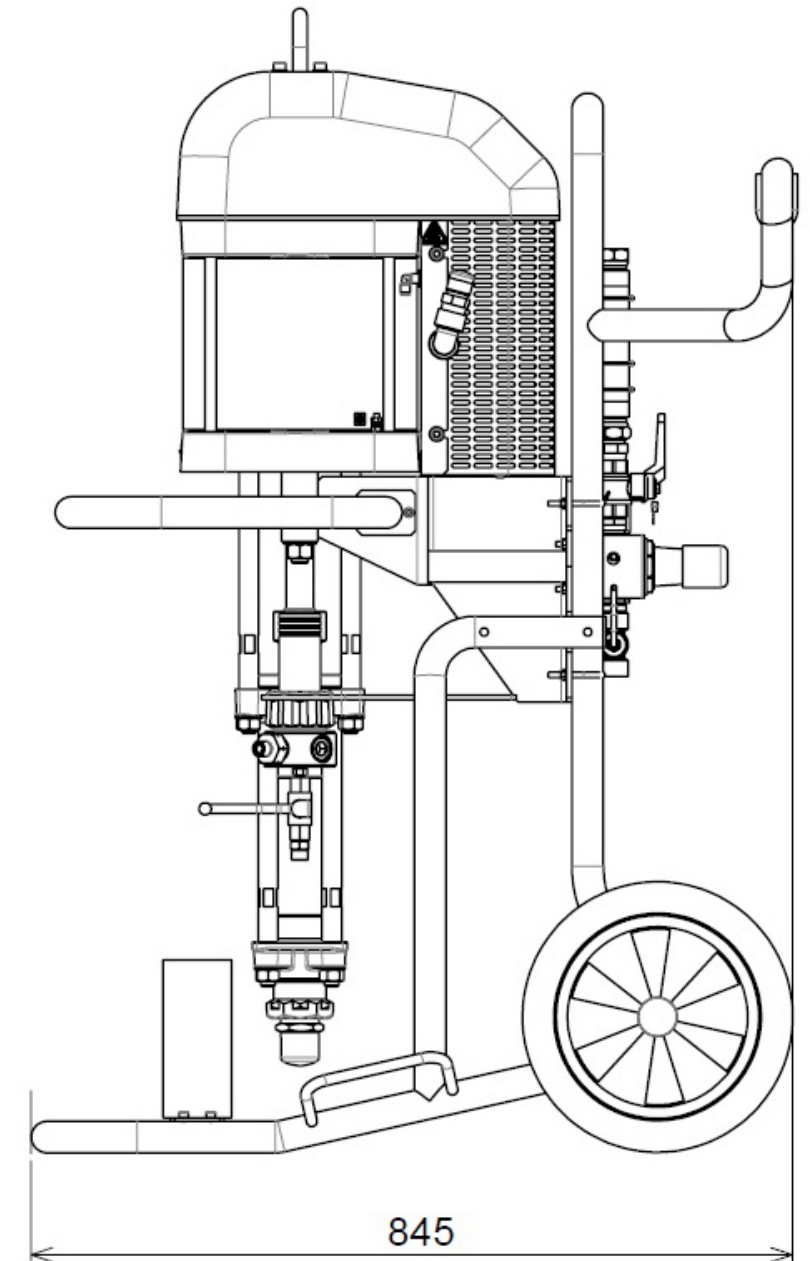
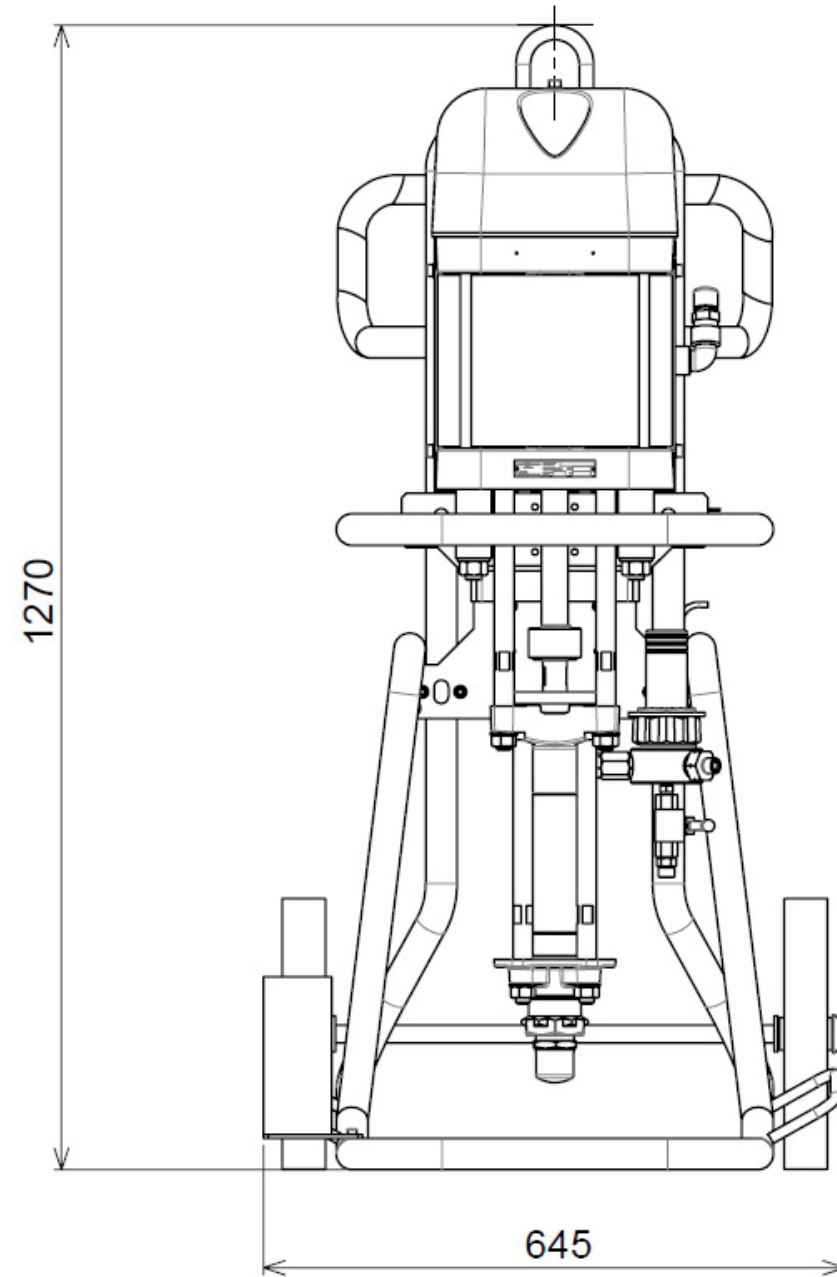

Pump 52C225 + Cart + Hopper

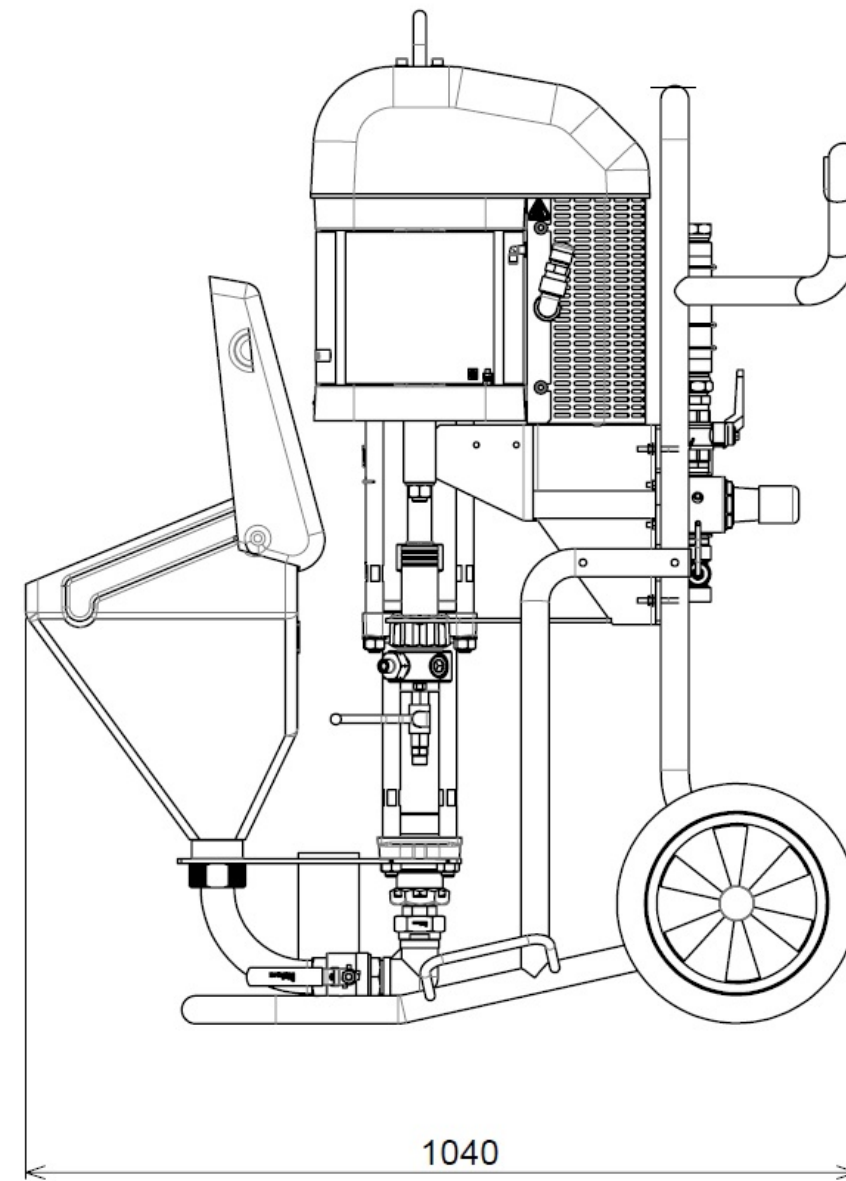
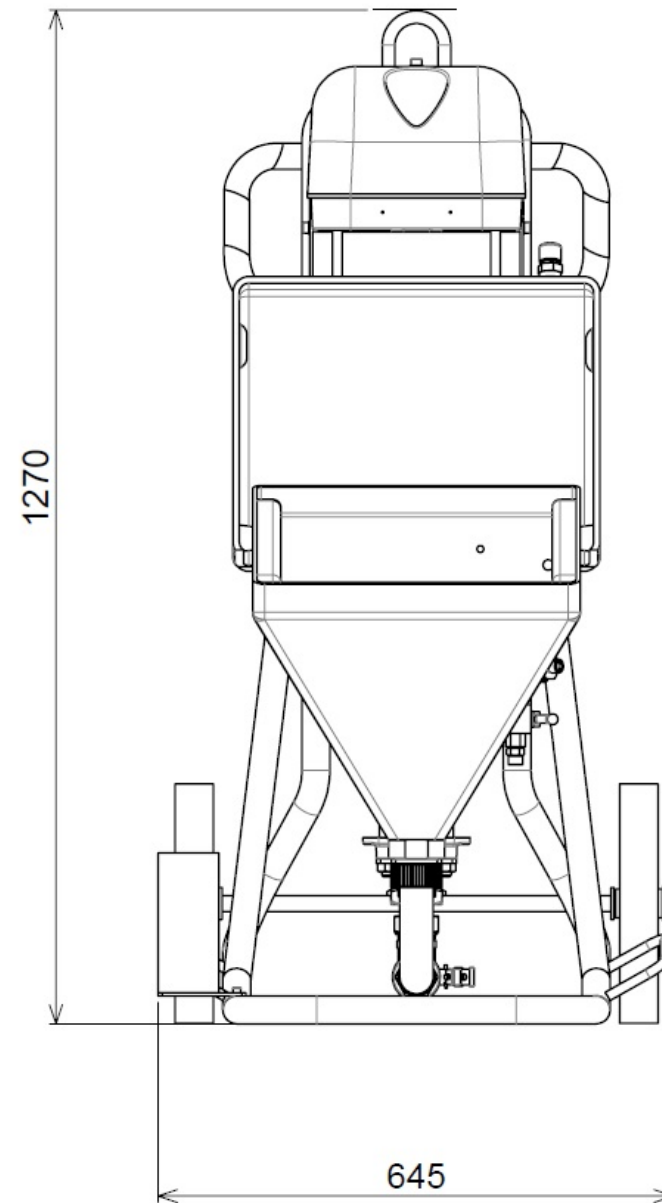

Fluid section C225

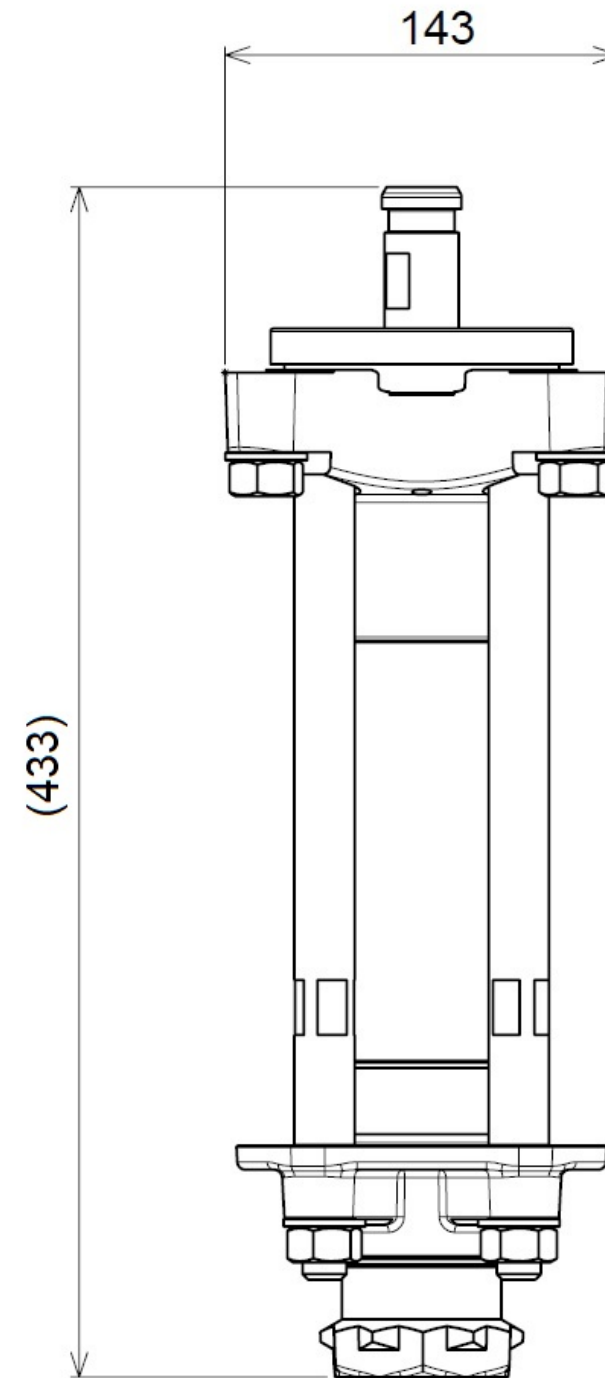

Motor 7000 Stroke 120

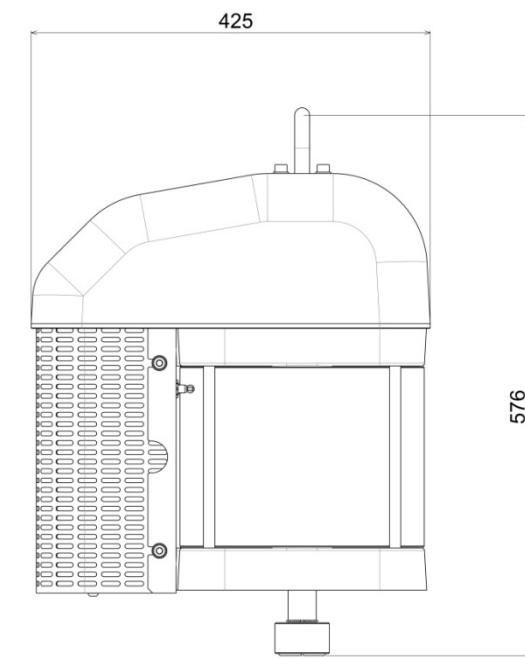
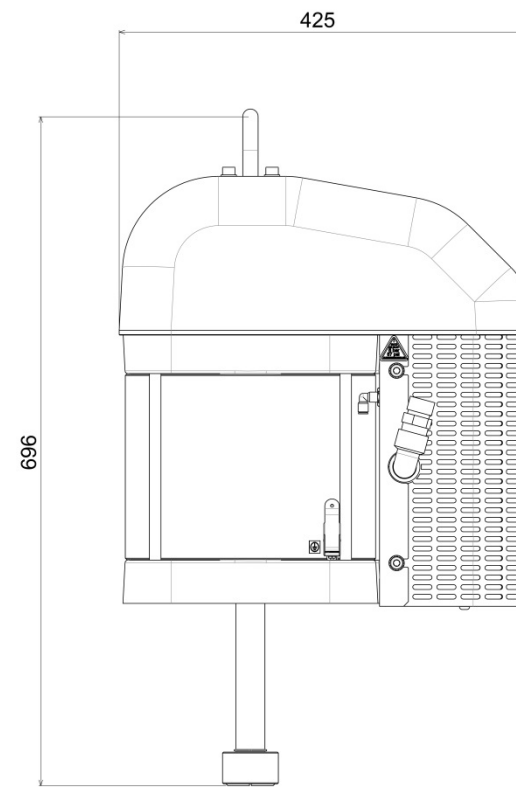
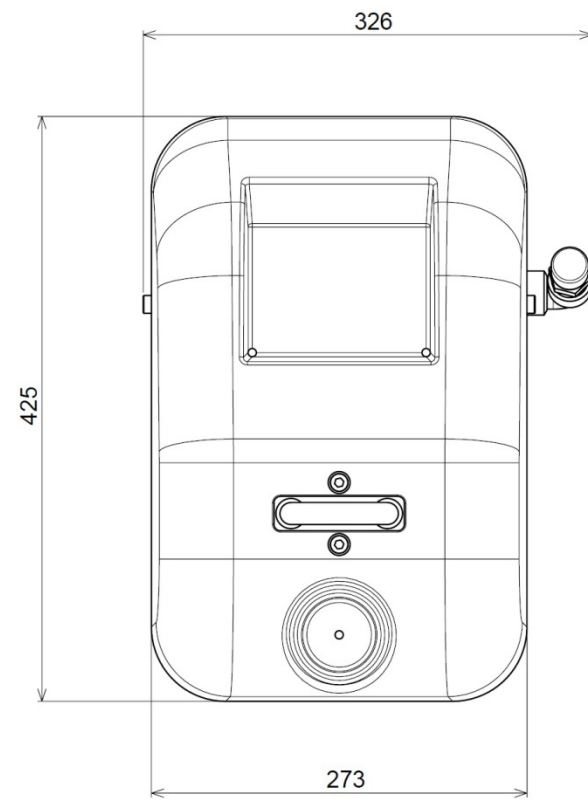

Air supply

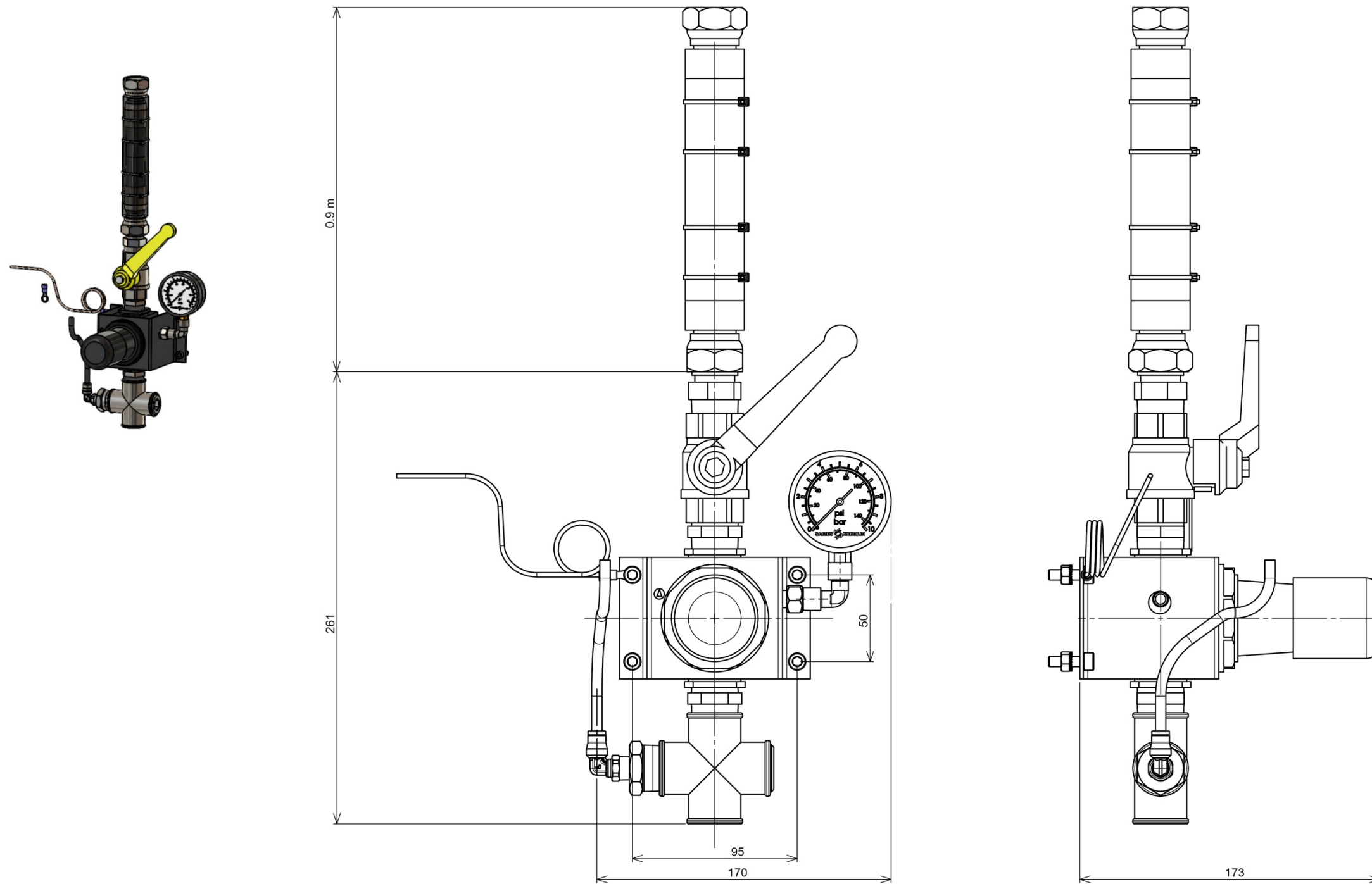

Filter

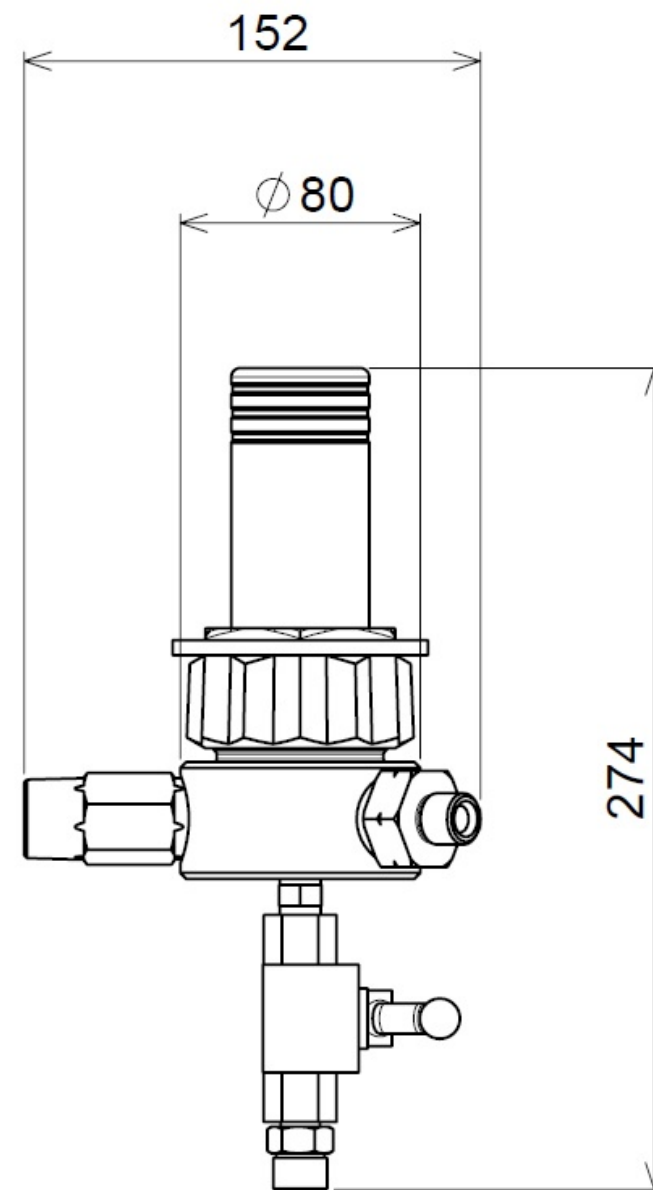
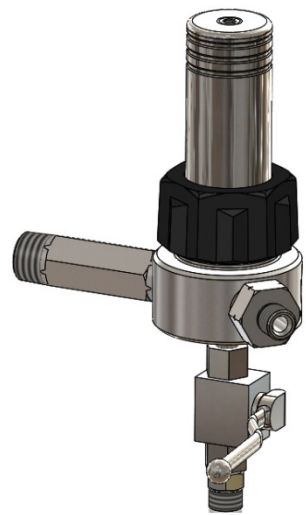

Pump priming kit

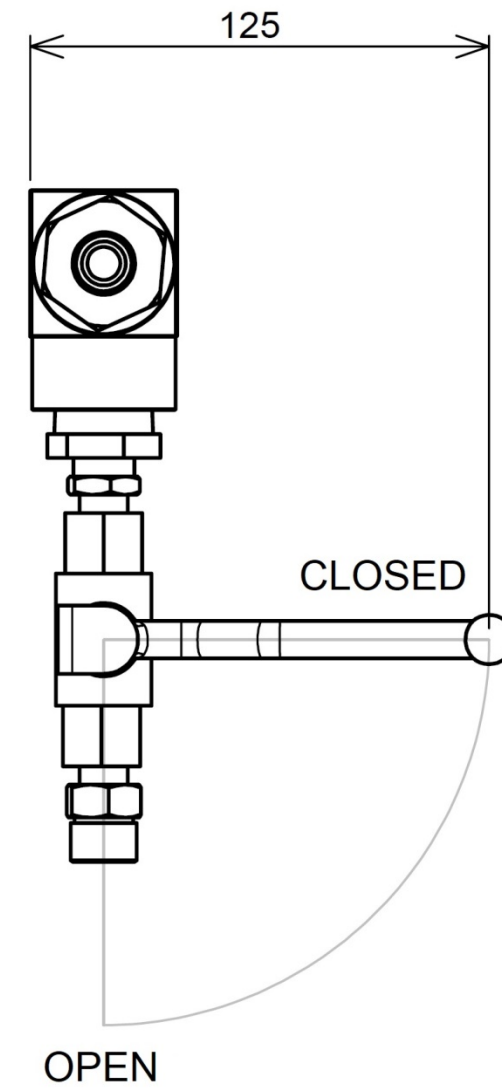
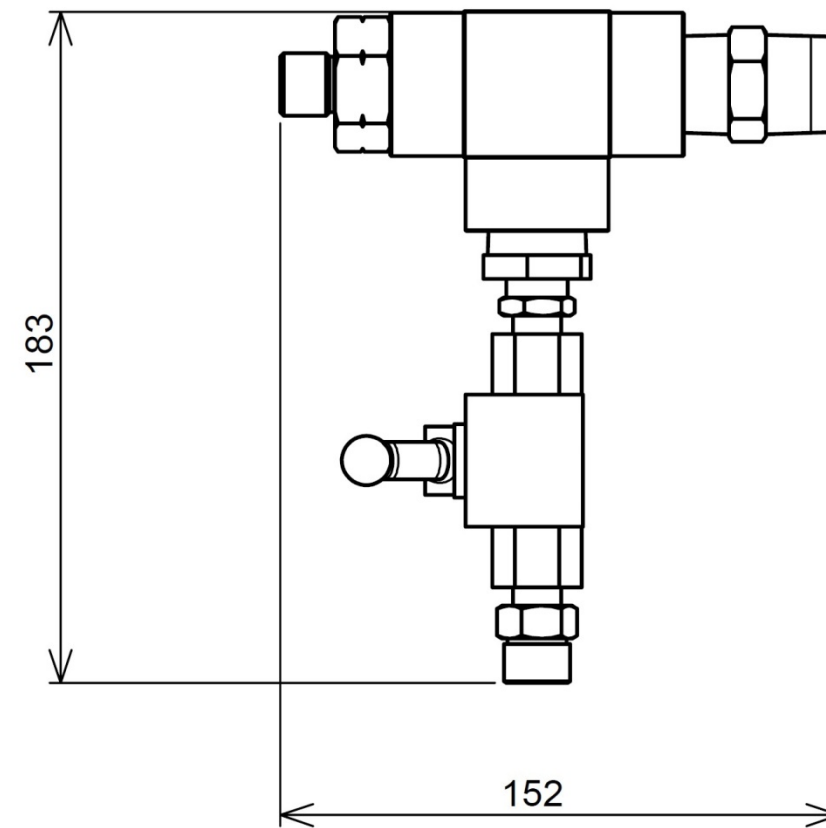
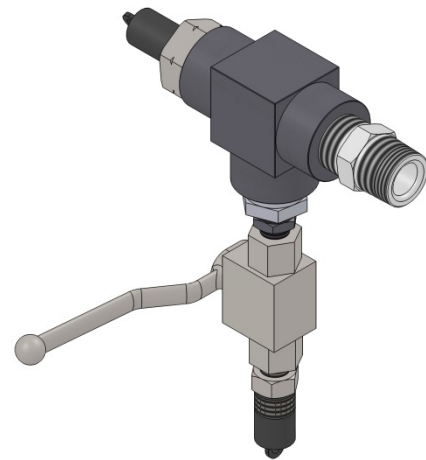

Hopper

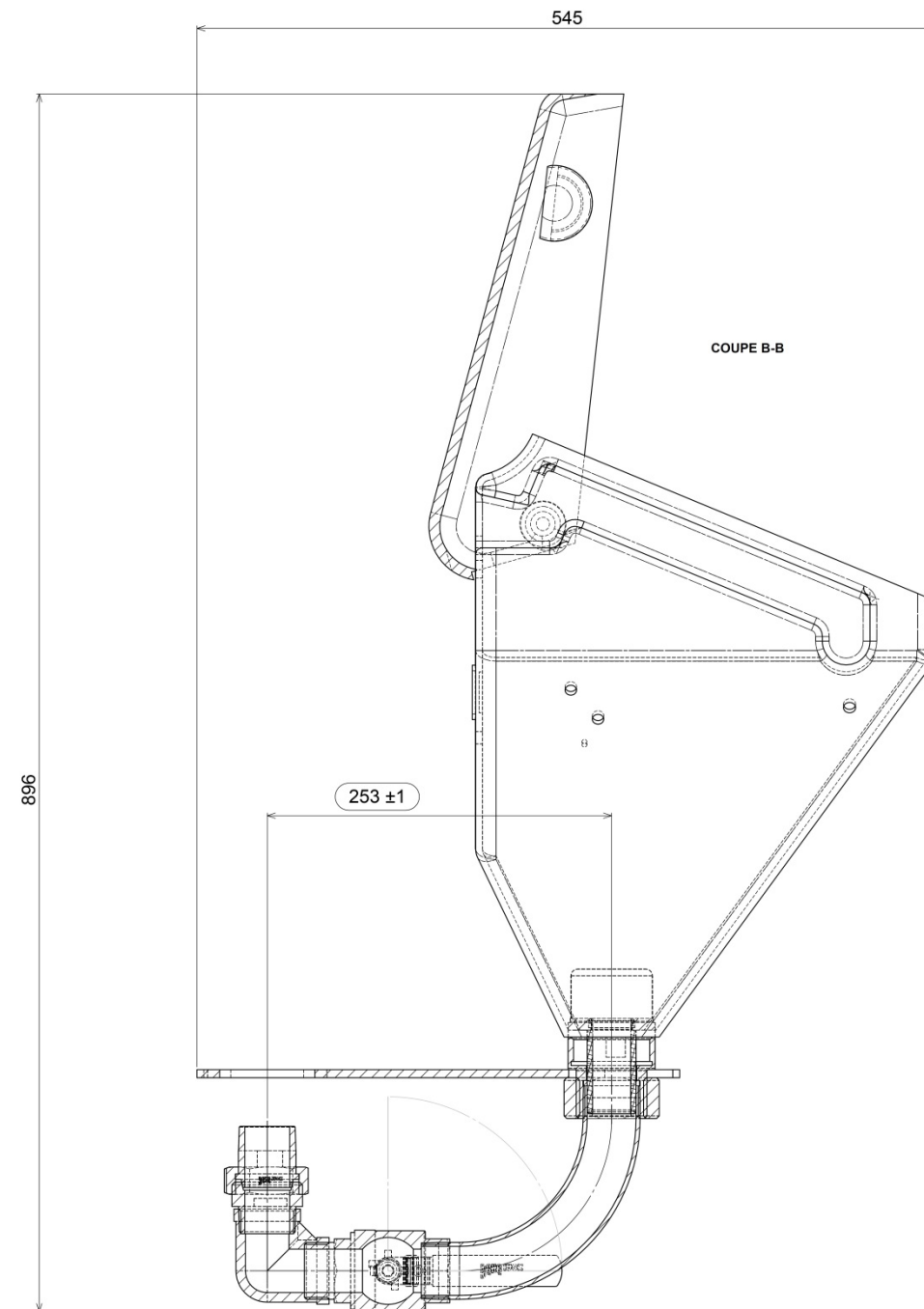
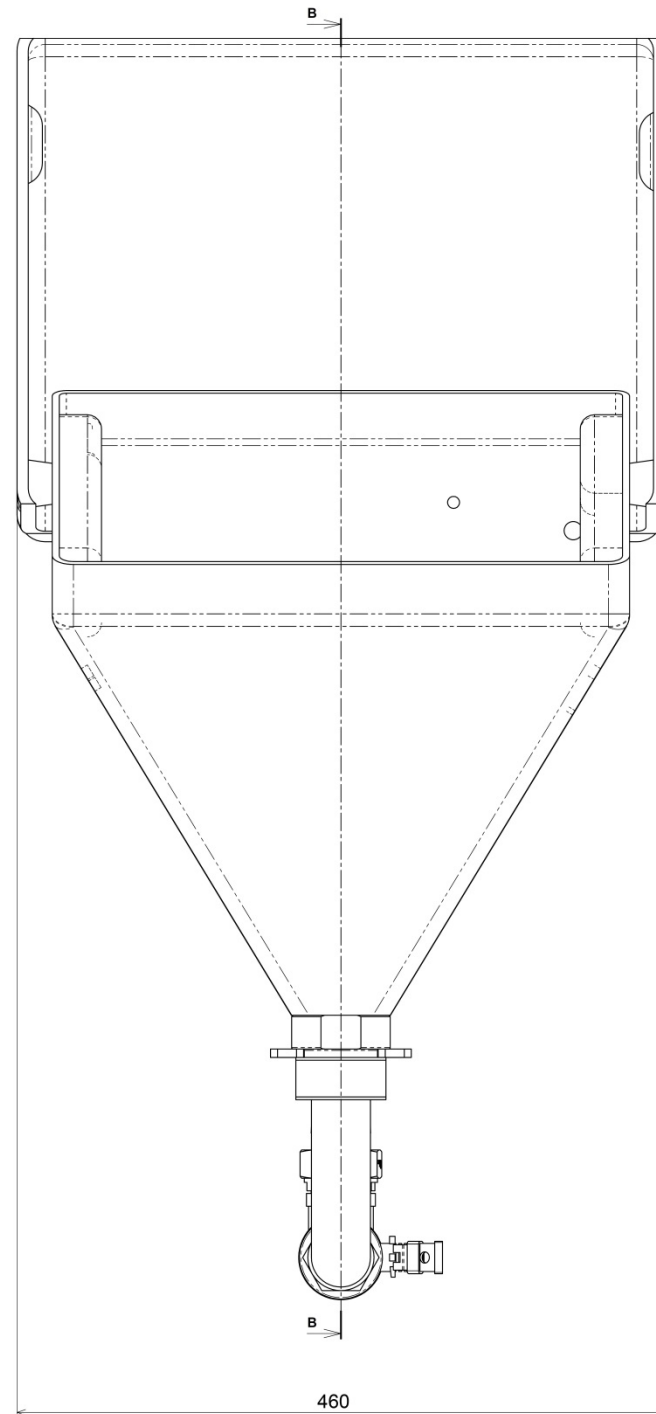

9 Technical specifications and operating principles

9.1 Technical characteristics

Pump 52C225



Theoretical weight

Type of pump 52C225	Weight
Naked	46 kg / 101.4 lbs
Wall mounted + Suction rod + air supply, without filter	58 kg / 128 lbs
Wall mounted + Suction rod + air supply +filter	61.5 kg / 134.5 lbs
Cart + Suction rod + air supply +filter	83 kg / 183 lbs
Cart + hooper + air supply +filte	83 kg / 183 lbs

Theoretical pressure ratio

- ✓ 52/1 - maximum product pressure: 312 bar / 4525 psi

Connection

- ✓ Air input- arrival: M 3/4 " BSP
- ✓ Product input: F G 1"1 / 4
- ✓ Output: F G 3/4 " (+ nipple MM 3/4 G - 3/8 NPSM)

Connection hoses

- ✓ Pump air supply hose: 3/4" BSP (Ø20)
- ✓ HP material hose: 3/8" NPSM (Ø9.5)

Motor 7000 - STROKE 120 - 146371000



Motor type:

- ✓ 7000-120
- ✓ Motor stroke : 120 mm
- ✓ Motor section : 484 cm²
- ✓ Weight : 35 kgs / 77.17 lbs

Fluid section C225

Fluid section C225 characteristics

- ✓ Fluid section C225: 94.8 cm²
- ✓ Volume of product delivered per cycle: 225 cc
- ✓ Number of cycles per liter of product: 4.4
- ✓ Flow rate at 20 cycles: 4.5

C225 Sealing gasket

- ✓ Fixed end: 8 chevron seals (4 UHMWPE + 4 PTFE or 4 PTFE + 4 UHMWPE or 4 UHMWPE + 4 PTFE G)
 - ✓ Inf. mobile: 6 chevron seals (3 UHMWPE + 3 PTFE or 3 PTFE + 3 UHMWPE or 3 UHMWPE + 3 PTFE G)
-

9.2 Principle of operation

Pump

The pump includes:

- ✓ A reciprocating air motor.
- ✓ A fluid section (mechanically linked to the engine).

The motor is supplied with compressed air.

In its reciprocating movement, the motor drives the piston of the fluid section, the paint is sucked up and is forced back under pressure.

Functional description

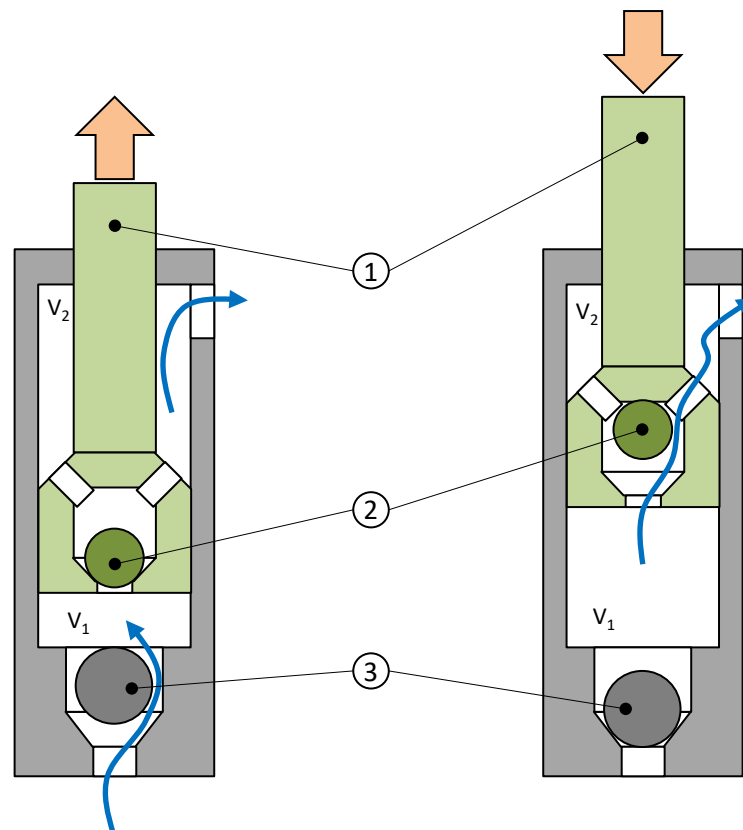

When the piston (1) rises, the Upper (2) closes or Lower Ball check (3) opens. The piston (1) expels the product from the upper chamber (V2) to the outside and sucks the product to fill the lower chamber (V1).

When the piston (1) is lowered, the upper flap (2) opens and the lower flap (3) closes. The piston (1) compresses the fluid in the lower chamber (V1) and transfers it to the upper chamber (V2). Since the volume of the upper chamber (V2) is half that of the lower chamber (V1), a volume equivalent to the upper chamber (V2) is expelled from the pump

**Attention**

The friction caused by the movement of the product inside the pump and its accessories as well as those caused by the seals, creates static electricity that can cause fire or explosion. It is therefore necessary to connect the fluid section to earth via the motor ground cable (see motor instructions for grounding).

Never place your hand on the suction port of the pump. The suction power may cause serious injury.

Motor operation description

SAMES KREMLIN pneumatic motors with straight reciprocating movements operate by compressed air supply. The inversion system is carried out via:

- ✓ two switches,
- ✓ A 5/2 bistable distributor,
- ✓ A 4/2 bistable distributor.

These pneumatic motors are intended to be coupled to the fluid section systems recommended by SAMES KREMLIN in order to obtain the ratio and the expected flow rate.

10 Installation

Pump

The pumps are designed to be installed in a paint booth or outside.

Connections subsets

Motor – fluid section

These fluid sections are intended to be coupled to pneumatic motors compatible stroke.

It is imperative to comply with a motor / fluid section combination provided by SAMES KREMLIN

Grounding



Coupled with a pneumatic motor, the fluid section will be grounded via the earth cable of this motor.

This ground cable must be connected to a safe ground.

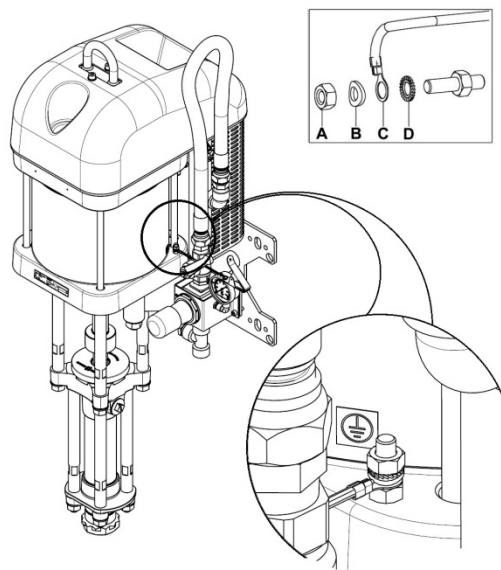

- ✓ Loosen the lock nut (A), remove the washer (B), insert the terminal (C) with its ground wire (min. Section: 1.5 mm²) between the washer (B) and the washer (D).
- ✓ Retighten the lock nut. Connect the other end of the wire to a real "earth" that complies with the regulations of the country concerned.
- ✓ Have the earth continuity checked by a qualified electrician.

- ✓ If earth continuity is not assured, check terminal, wire, bracket, and grounding point.
 - ✓ Never operate the pump without having solved this problem.
-

Connection to compressed air supply

Set the pressure at the air regulator.

For proper operation and long life of the engine, the supply air must be filtered and not lubricated (see § Maintenance).

- ✓ It is imperative to install a decompression valve after the air regulator and as close as possible to the engine inlet in order to follow the decompression procedure (See the pump manual § Operating problems).
- ✓ The engine air supply hose must have an inside diameter of at least 19 mm.
- ✓ The engines are tested before shipping. Nevertheless, before coupling the motor to a pump, it is necessary to operate it under vacuum at a pressure of 1 bar / 14.5 psi maximum for a few minutes.

Proceed as follows:

- ✓ Couple the motor with the recommended pump.
 - ✓ Connect the main air supply to the motor.
-

10.1 Storage

Pump

Place the equipment away from moisture after closing the various air inlets and various openings (plugs).

Storage before installation:

- ✓ Storage ambient temperature: 0 / +50 ° C.
- ✓ Protect the unit against dust, water runoff, moisture and shocks.

Storage after installation:

- ✓ Protect the unit against dust, water runoff, moisture and shocks.
-

10.2 Handling

Pump

Pumps and fluid section of significant weight and size must be handled with appropriate means.

11 Commissioning

Pump

The pumps are tested in our workshops with lubricant.

Prior to start-up, this lubricant must be removed by rinsing with a suitable solvent.

At the end of the day, rinse with a suitable solvent.

It is advisable to stop the fluid section in the "low inversion" position in order to prevent the product from catching on the piston rod.

Motor

Engines are tested before shipping.

Nevertheless, before coupling the motor to a pump, it is necessary to operate it under vacuum at a pressure of 1 bar / 14.5 psi maximum for a few minutes.

12 Use of equipment

12.1 User settings

Pump

Before commissioning, fill the cup with lubricant "T".

Motor

Note: the motor is wired in direct control. Start pressure about 500 grams.

12.2 Safety in production



Guards (motor cover, coupling guard, housings, ...) are set up for safe use of the equipment.

The manufacturer can not be held responsible in case of bodily injury as well as breakdowns and / or damage of the material resulting from the destruction, the occultation or the total or partial removal of the protectors.

12.3 Recommended range of use

This design does not allow the use of the pump in paint recirculation system



- ✓ **Red** : transitory zone to achieve higher pressure : never stay on this zone while operation – up to 0.3Br Long operation on this zone will generate material leakage on the cup lub
- ✓ **Vert** : Long operation on this zone will generate material leakage on the cup lub
- ✓ **Orange** : Long operation on this zone may mean that the pump is undersized



*The pump does not come with a colored manometer.

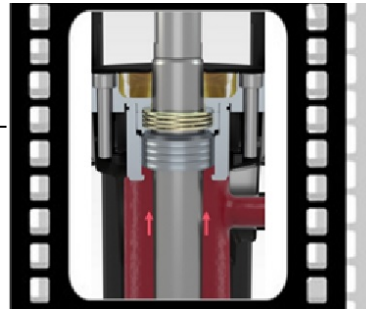

Under pressure

12.4 Diagnostic help / Troubleshooting guide

Troubleshooting

Before any intervention on a pump, it is imperative to carry out a general procedure of decompression and purge.

In order to avoid the risk of personal injury, product injections, injuries caused by moving parts or arcing, it is essential to follow the following procedure before any intervention during system shutdown, assembly, cleaning or changing the nozzle.

- ✓ Lock the guns (valve, tap, etc.) to OFF.
- ✓ Shut off the air supply through the decompression valve in order to evacuate the residual air from the motor.
- ✓ Unlock the gun (valve, tap ...).
- ✓ Bring the gun (valve, tap ...) to a metal bucket to collect the product. Hold it against the wall of this bucket to avoid interrupting the continuity of the earthing (use the wire with stirrup to put the metal bucket to earth).
- ✓ Open the gun (valve, tap) to bleed the circuit.
- ✓ Lock the gun (valve, tap) to OFF.
- ✓ Open the pump bleed valve and collect the product in a well-grounded metal bucket.
- ✓ Leave this purge valve open during the whole period of the operation.

Check the conformity of the wiring before intervention.

Ice formation

When the compressed air is exhausted, the sudden drop in pressure causes the air temperature to drop below 0°C / 32°F. Any liquid or water vapour then turns to ice.

Higher air pressures pack high amounts of air and water vapor in each cycle and create more expansion and ice. Higher cycle rates also build up the ice and lower the motor temperature faster.

Warm humid climates can produce high levels of icing because of the higher humidity levels. Low ambient temperatures near 0°C / 32°F make it easier for the motor parts to drop below freezing.

To minimize ice build-up:

- ✓ Use an air dryer, coalescing filter or desiccant filter to lower the water vapor content of the air.
- ✓ Raise the compressed air temperature. Warmer air going in helps the motor parts stay above 0°C / 32°F. Compressed air, especially at these volumes, is warm when compressed. Keep the air warm to the compressor to reduce ice formation.

12.5 Possible symptoms of faults / Causes of faults / Remedy to be applied - fast operation

Possible symptoms of faults / Causes / Remedies Fluid section part

Defaults	Possible causes	Remedies
Leakage at the upper fluid section seals	Insufficient tightening of the packing nut	Tighten the packing nut.
	Damaged or worn seals	Replace them.
	Incorrect selection of the material of the joints	Check compatibility.
The upper seals of the fluid section deteriorate quickly	Absence of lubricant in the cup (drying of the pumped product on the piston rod)	Clean, replace parts if necessary. When stopping for a long time, stop the pump with the piston in the down position.
	Product compatibility / seals	Check.
The pump is stopped	The product is cured, dried in the pump	Clean the fluid section, change the parts if necessary.
	Breakage of part (s) in the pump	Disassemble, check, replace.
The engine seems to be working but the pump does not deliver product	Internal parts of the motor failing	Check the operation of the motor.
	Faulty hitch	Check the hitch.
The pump works but irregular flow	Check valve stuck on its seat, incorrectly mounted or worn	Check the assembly, the condition of the parts, the tightening of the elements and the joints.
	Air intake in the suction circuit	
With the pump stopped, the piston continues to descend	Lower valve worn or incorrectly mounted	Check and replace parts.
	Unsealed plug or drain valve	
With the pump stopped, the piston continues to rise	Top seals or top valve worn or incorrectly mounted	Check and replace parts.
	Unsealed plug or drain valve	

Defaults	Possible causes	Remedies
The piston goes down quickly (single effect operation)	The pump is badly filled	Check the parameters of use of the accessories (on follower plate or suction rod). These may be poorly adapted or obstructed.
	The product is too viscous	Bad definition of the pump.
	Lower valve worn	Check and replace parts.
	Foreign body clogs lower valve	Clean and check.
	Lower check valve too low	Adjust the ball cage screw to increase lift. Block with the lock nut.
The piston rises quickly	Upper valve worn or damaged	Check and replace parts.
	Foreign body obstructs top valve	Clean and check.
The piston goes up and down at different speeds	Valves, piston seals or used cylinder (s)	Replace the parts.
	Poor installation of damaged seals or seals	Check the assembly; change if necessary.
The pump does not deliver enough pressure	Insufficient engine air pressure (insufficiently open valve, air leak)	Check, adjust.
	Insufficient engine air supply (poorly adapted hose) or clogged exhaust	Check filter, fitting, incorrectly fitted hose.
	Gold tassel piston head gaskets too tight	Check the assembly or loosen the packing nut.
Abnormal operation after runaway or high temperature	Piston or packing gaskets too tight, damaged	Check the assembly, reduce the pumping rate. Replace the parts if necessary.
	Empty product tank	Fill the tank, check the suction circuit, the absence of air intake.
High pressure drop on descent	Lower check valve too high	Adjust the ball cage screw to limit lifting. Block with the lock nut.
Leakage of product by the body of the pump	Cylinder poorly tightened	Check and replace parts if necessary.
	Absence of damaged joints or joints	

Possible symptoms of faults
/ Causes / Remedies Motor
part

Perform a decompression procedure before any intervention:

- ✓ shut off the air supply with the pressure relief valve in order to evacuate residual air from the engine,
- ✓ decompress the circuit produced by opening the purge valve of the pump or the gun.

Description	Causes	Remedies
Motor piston lock	Defective switch	Adjust or replace the switch(es)
	Defective control distributor	Check operation, replace if necessary
	Defective power distributor	Check operation, replace if necessary
Decrease of product flow	Escape leak	Check the piston seals, change them if necessary
		Check the distributor seals, change them if necessary
	Silencer clogged	Clean or change the muffler
Large exhaust leak	Improper installation of the distributor base gasket	Reassemble the seal in the correct direction
	Defective power distributor	Check operation, replace if necessary.

13 Maintenance

13.1 Preventive Maintenance Plan

**Attention**

Before any intervention, it is imperative to follow the decompression procedure and the safety instructions.

During prolonged shutdown, stop the pump when the piston is in the down position.

Fluid section part

Daily

- ✓ Detect leaks at connections.
- ✓ Check the condition of the hoses.
- ✓ Clean the piston of the pumps. Do not let the product dry on it.
- ✓ Check the lubricant level inside the cup (keep it at half level).
- ✓ Fill it if necessary.

**Note: It is normal for this lubricant to stain.**

- ✓ Maneuver all the valves of the installation.
 - ✓ Clean the site and the environment.
-

Twice a month

- ✓ If the lubricant is strongly colored in the cup, renew it.
- ✓ Check that the cup remains clean and clean it regularly with solvent after draining the lubricant.

Once a month

Check that the air regulator and pressure gauge are working properly.

Every year

- ✓ Disassemble the fluid section fully.
 - ✓ Clean all parts. Fit new seals when reassembling the pump (see replacement seal kit).
 - ✓ Put grease on the piston and inside the cylinder, to avoid damaging the seals.
 - ✓ Fit new parts if necessary.
-

Motor part



Attention

The motor is subject to the ATEX directive and must not be modified under any circumstances.

Failure to comply with this recommendation does not engage our responsibility.

The motor is designed to keep maintenance to a minimum (filtered supply air).

It is advisable to provide preventive maintenance after 12 months of operation.

Check:

- ✓ The clogging of the air filter.
- ✓ The absence of air leaks.
- ✓ The absence of breaks in the air hoses.
- ✓ The correct snapping of the connections / hoses.
- ✓ The general condition of the supply hoses (rubber, crimping), regulators and manometers.
- ✓ The tightening of the components.
- ✓ The condition of the muffler (s).
- ✓ The fixing of the hood.
- ✓ The correct operation of the safety valve.
- ✓ The state of the decompression valve.
- ✓ SAMES KREMLIN recommends changing the motor muffler foams every year.

Instruction	Designation	Reference
Anti-seize grease	Box of grease (450 gr / 1lb)	560.420.005
High performance grease	Box of fat Kluber petamo HY 133N (1 kg /2.2 lbs)	560.440.005
Anaerobic Glue PTFE Waterproof Tube	Loctite 5772 (50 ml / 1.7 oz)	554.180.015
Anaerobic adhesive low thread	Loctite 222 (50 ml / 1.7 oz)	554.180.010
Anaerobic adhesive strong thread	Loctite 270 (50 ml / 1.7 oz)	554.180.004
Anaerobic adhesive waterproof for seals	Loxeal 58-31 (75ml / 2.5 oz)	554.180.001

This maintenance consists of replacing parts with cuts or wear and cleaning organs with compatible products without using abrasive materials that could damage them. The O-rings are mounted with special "pneumatic" grease.

Make sure that none of them get damaged; cutting one of them may cause the engine to malfunction.

13.2 Preventive maintenance

Fluid section

It is recommended to schedule a routine maintenance after a set number of hours of operation.

This is defined by the user's maintenance department and is based on the product, the work rate and the usual pressure.

Be aware of the disassembly / reassembly of the pump and spare parts.

14 Disassembly/Re-assembly of the 7000 motor



Attention

Before any intervention, it is imperative to follow the decompression procedure and the safety instructions.

14.1 Disassembly

Disassembly of the grounding cable

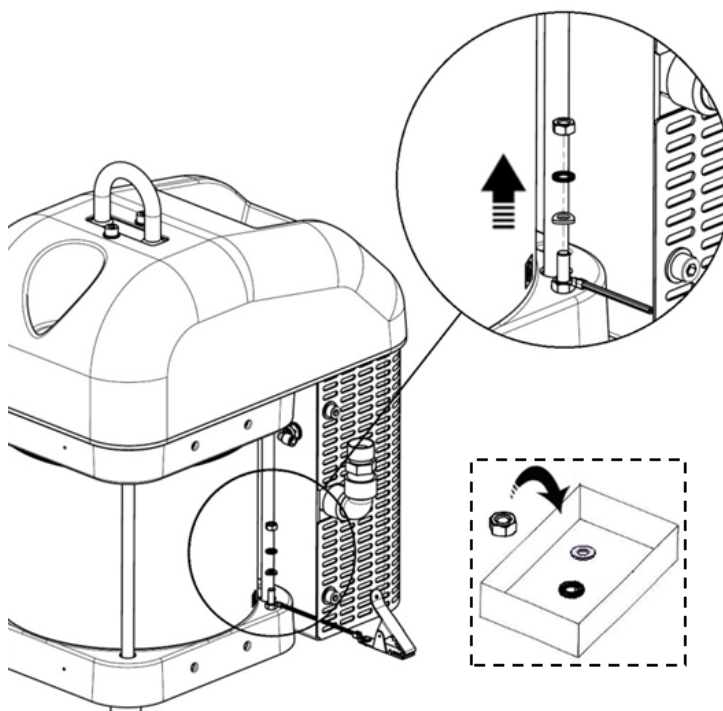

- ✓ Hold the grounding terminal with a 10 mm spanner and unscrew the upper nut with the other key.
- ✓ Remove the washers and the grounding cable.

Tools needed

10 x2



Preliminary operations

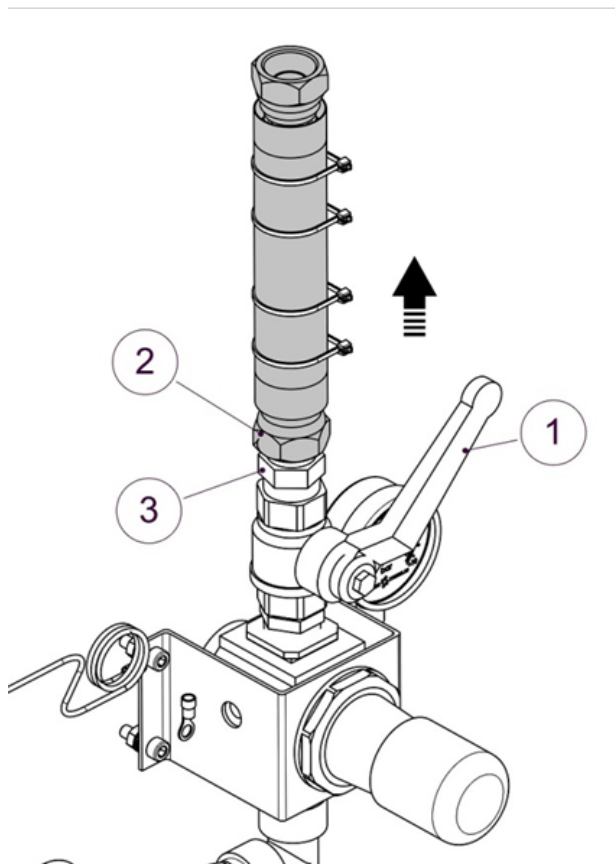

Option

- ✓ If the pump is equipped with air equipment:
 - turn off the air supply with the valve (1).
- ✓ Unscrew the air supply hose (2) with a 32 mm spanner, blocking the air inlet fitting (3) with a 27 mm spanner.

Tools needed

27



32



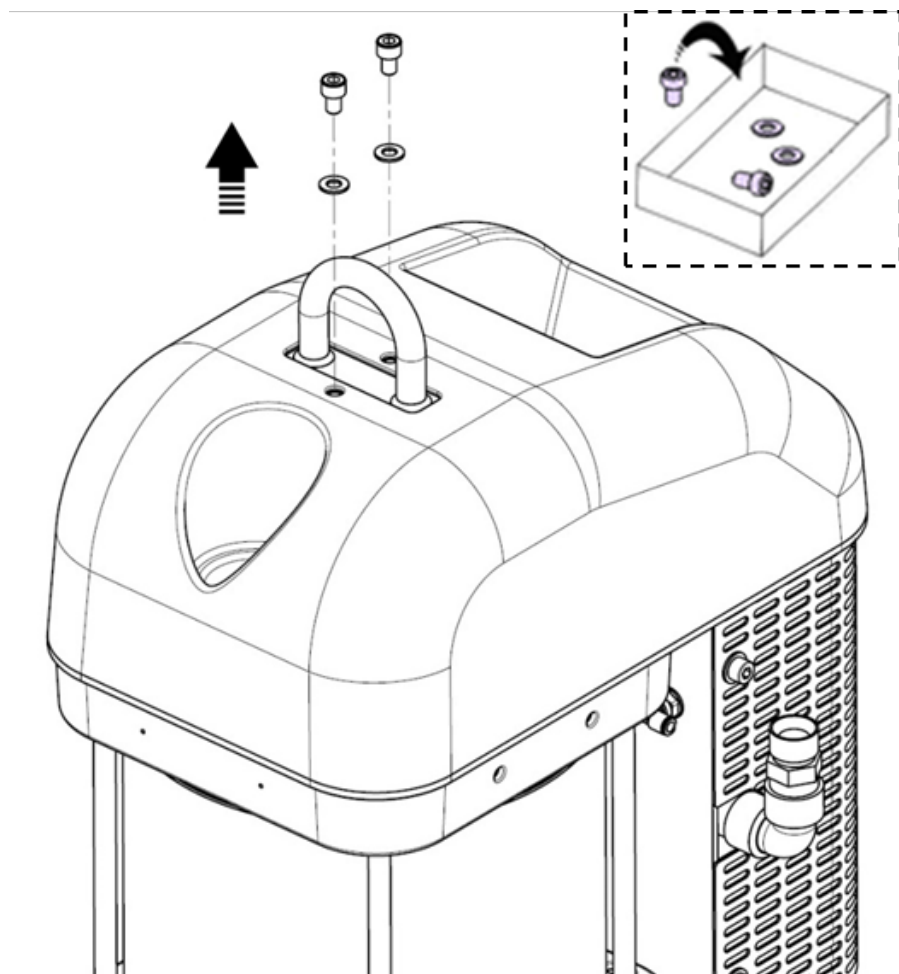

- ✓ Remove the 2 screws with a 6 mm BTR wrench and then the washers from the motor cover.

Tools needed

6 

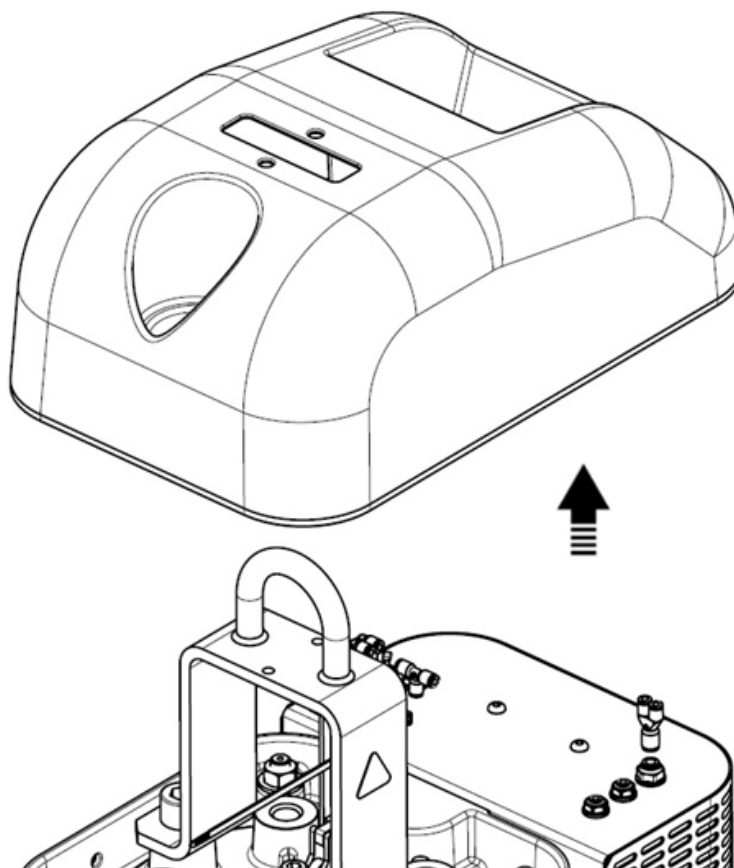

✓ Remove the motor hood.

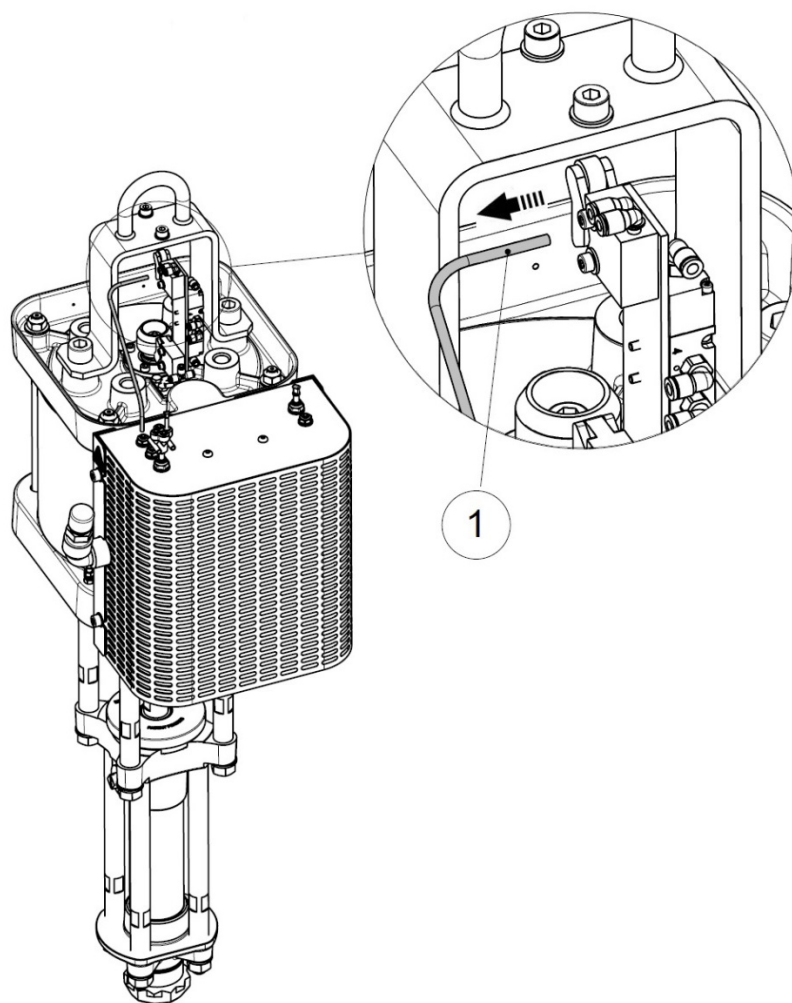

- ✓ If it is necessary to change the switches, first remove the pneumatic hoses manually.

Note: Locate hoses for reassembly.

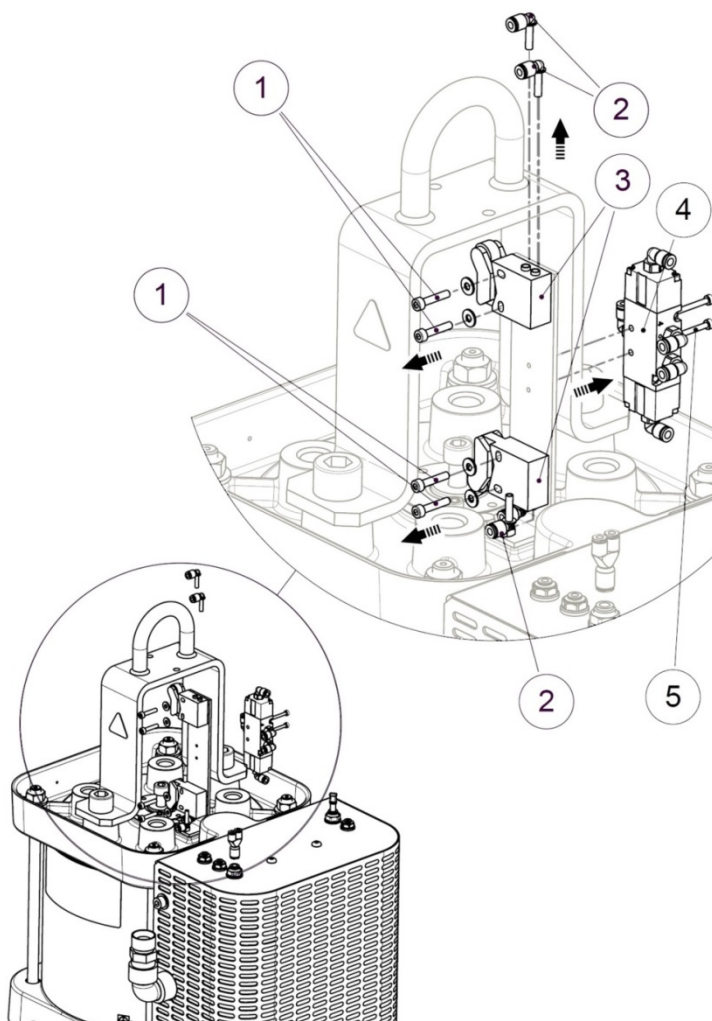

- ✓ Remove the 4 screws with a 3 mm BTR wrench and then the washers (1).
- ✓ Manually remove the connectors (2) and switches (3).
- ✓ Remove the 2 screws (5) with a BTR wrench of 3 mm.
- ✓ Manually remove the distributor (4)

Tools needed



14.2 Disconnect the motor and the fluid section

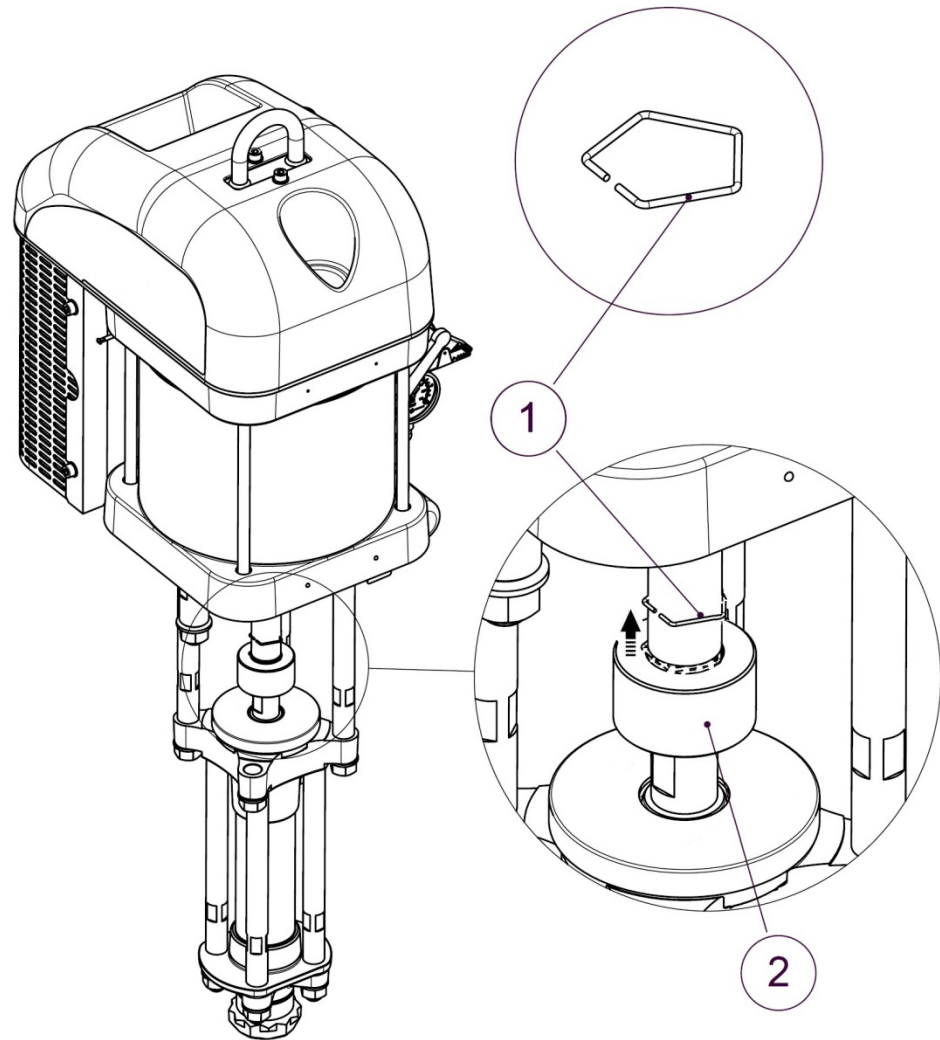

- ✓ Using a flat screwdriver, disengage the axle brake (1) from the groove above the locking ring (2), in order to release it.

Tools needed



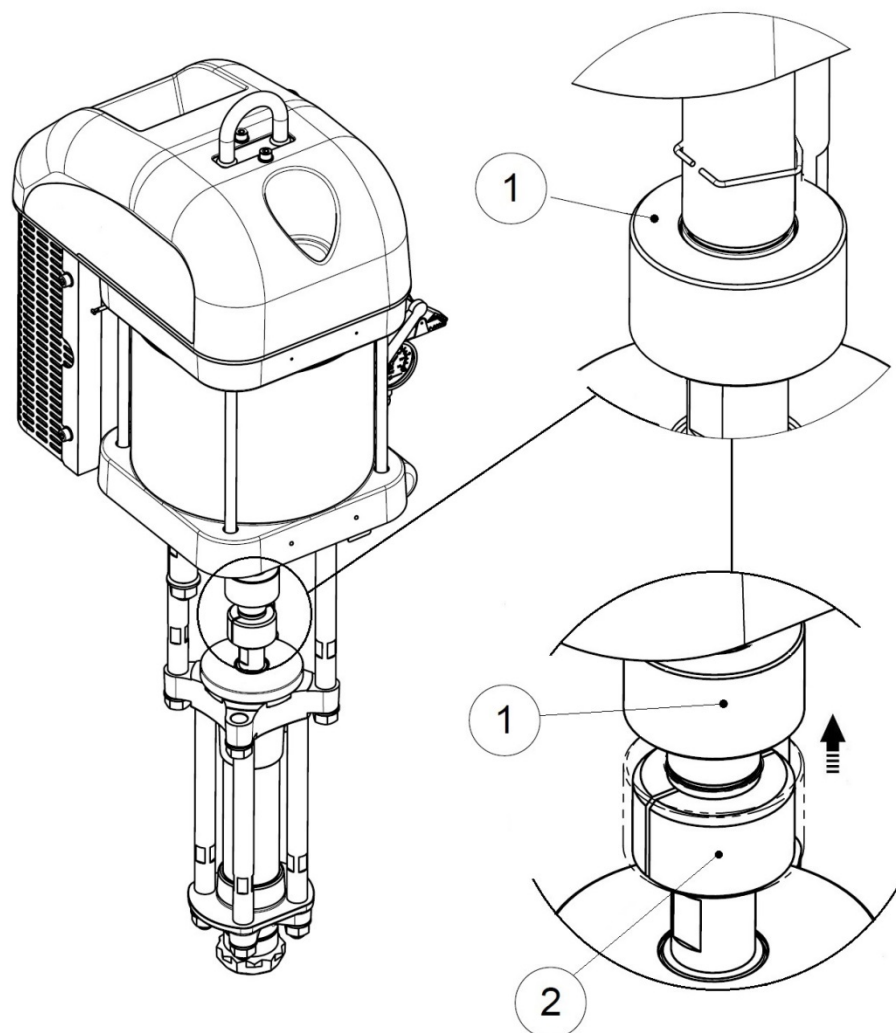

- ✓ Manually lift the locking ring (1) and manually remove the coupling nuts (2) underneath.

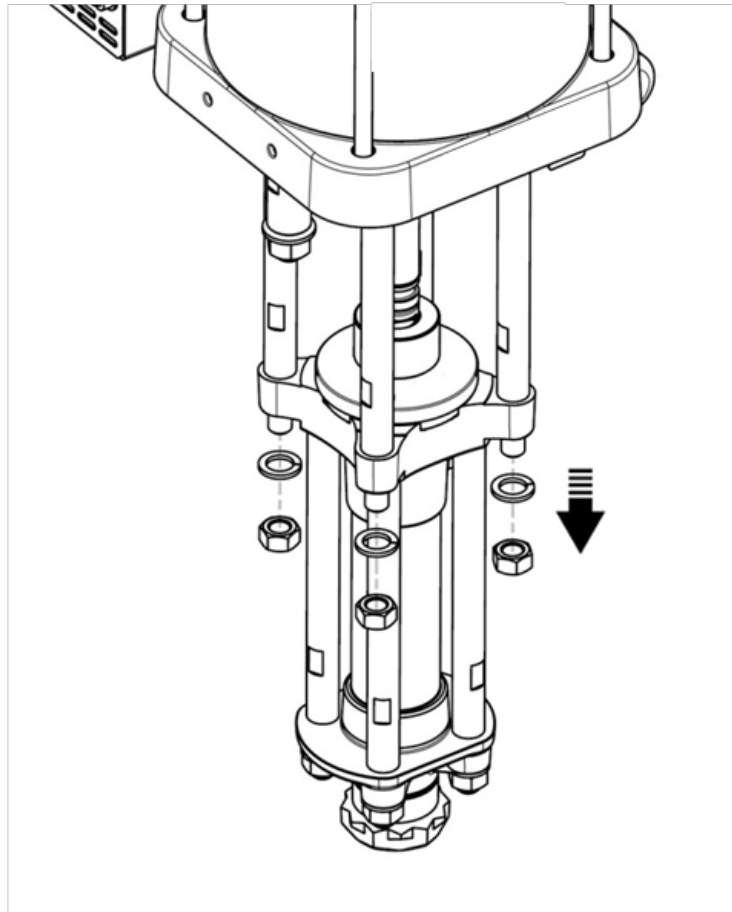

- ✓ Using a 24 mm wrench, unscrew the 4 nuts connecting the flange to the tie rods and remove the 4 washers.



Attention: Support the fluid section well (Fluid section weight: 11 kg / 24.25 lbs).

Tools needed

24



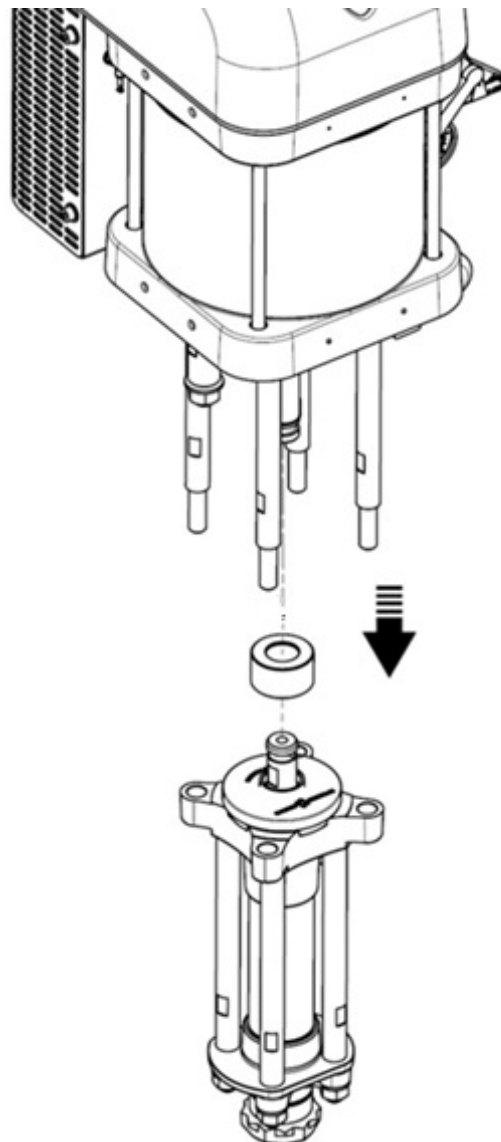

- ✓ Separate the motor from the fluid section and retrieve the closing ring.

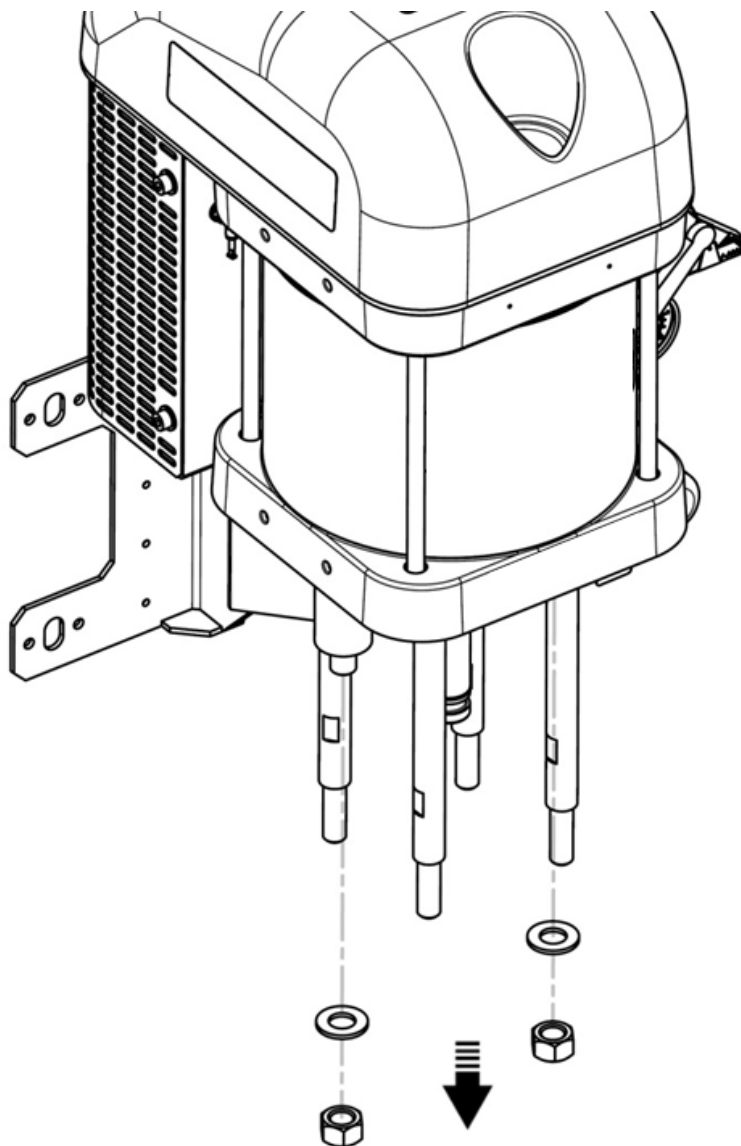

- ✓ If the motor is mounted on a support, unscrew the two nuts with a 27 mm wrench and remove the two washers from the handles under the lower flange.

Tools needed

27



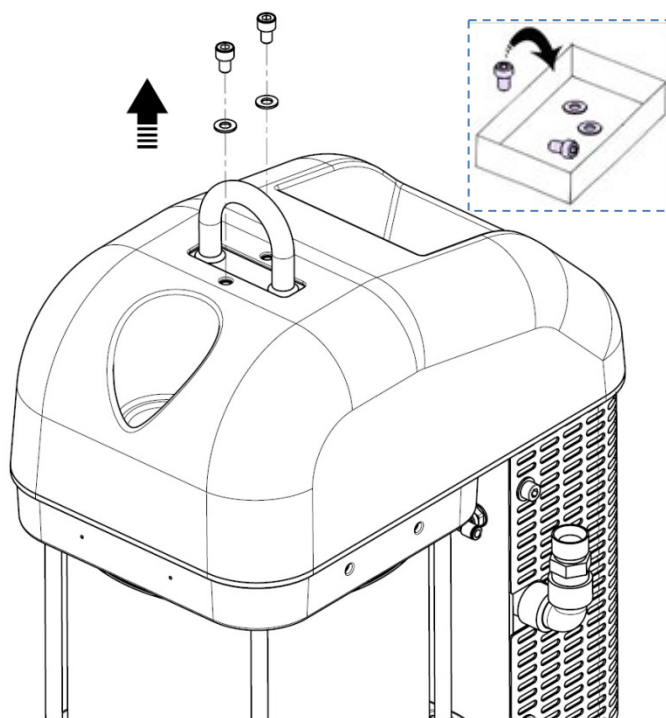

- ✓ If the engine hood has not been removed in the previous steps, remove the engine hood with a BTR wrench of 6 mm by removing the two screws and washers.

Tools needed



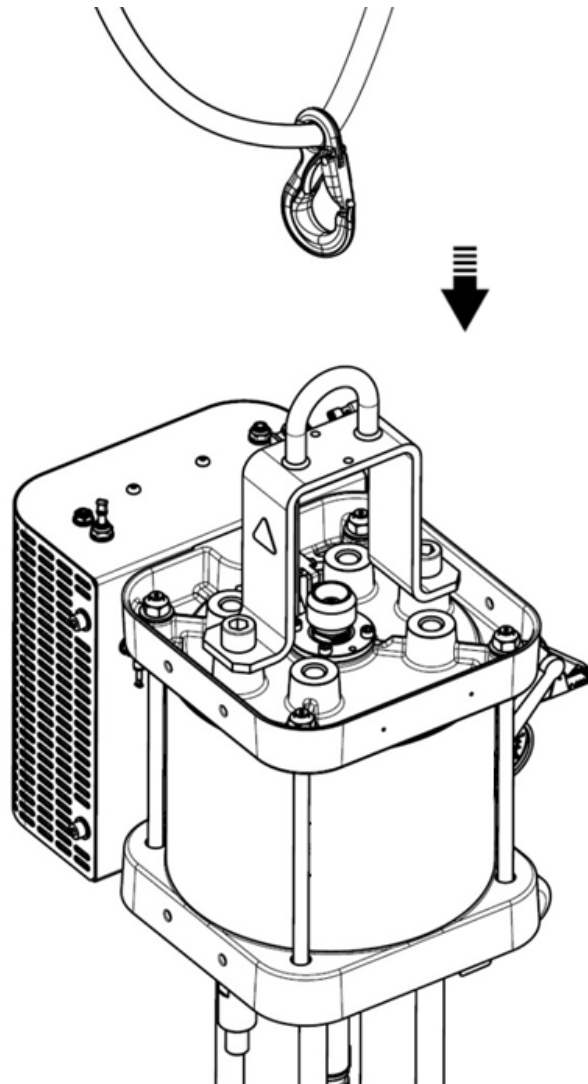

✓ Sling on the lifting ring / bracket.

Tools needed



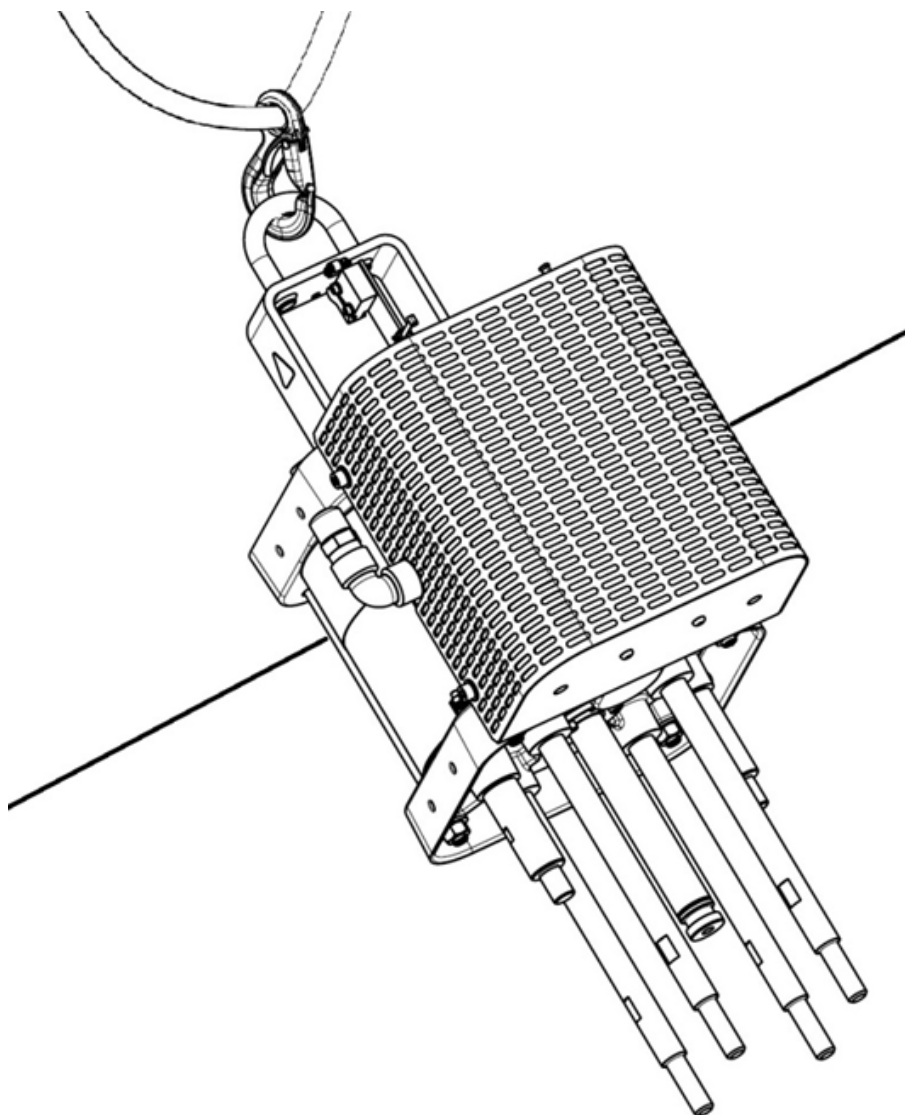

- ✓ Place the engine on a horizontal plane using a bridge or a stem.

Tools needed



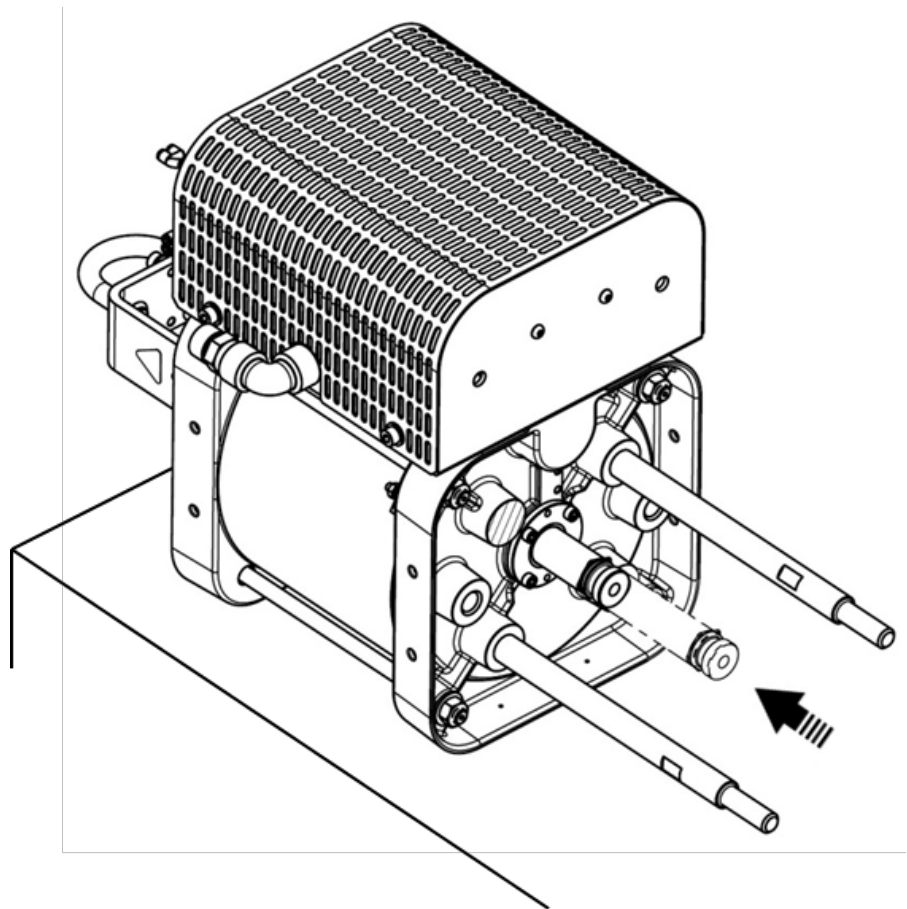

- ✓ Retract the motor shaft manually.

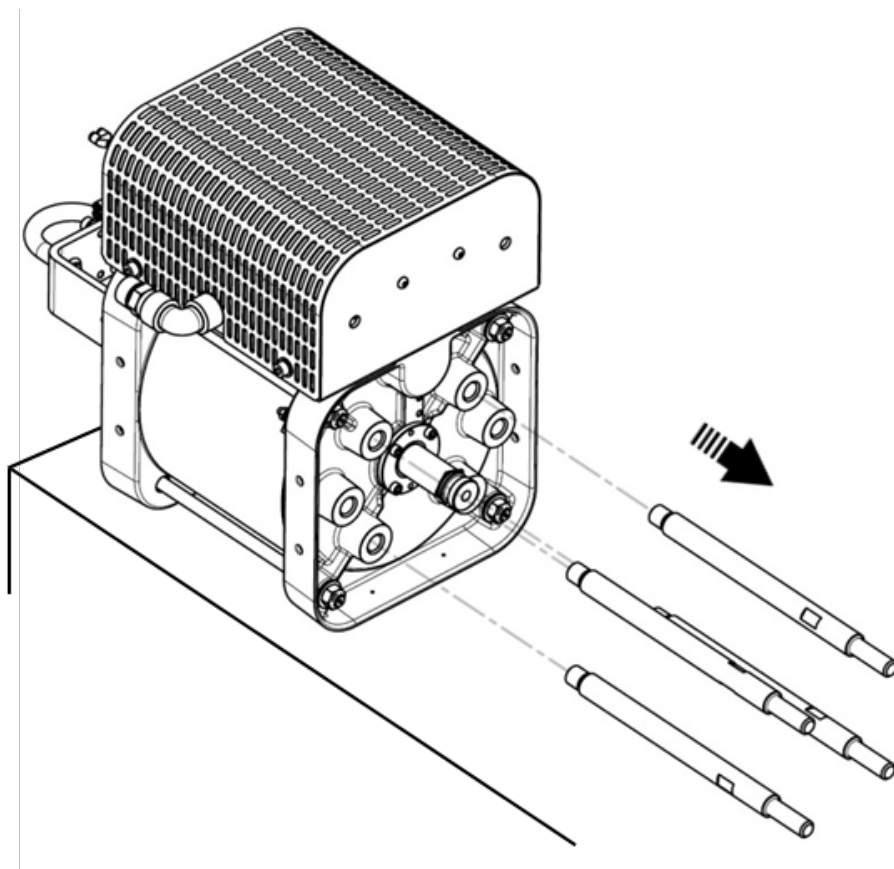

✓ Remove the 4 tie rods with a 19 mm wrench.

Tools needed

19



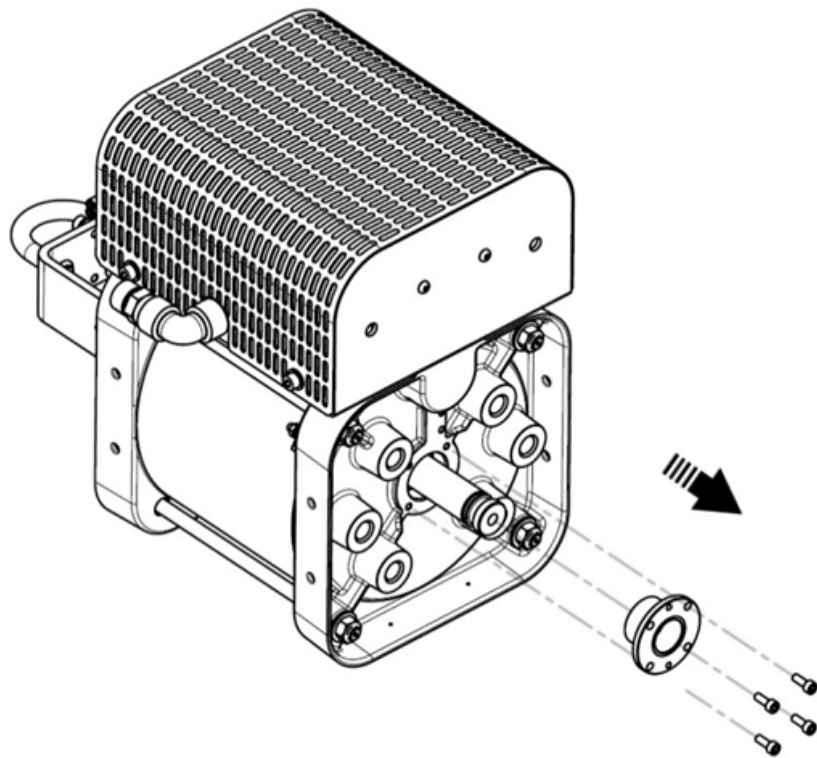

- ✓ In the event of disassembly of the lower bearing (change of seals), unscrew the 4 screws with a BTR wrench of 5 mm.
- ✓ Manually remove the lower bearing along the motor shaft.

Tools needed

5



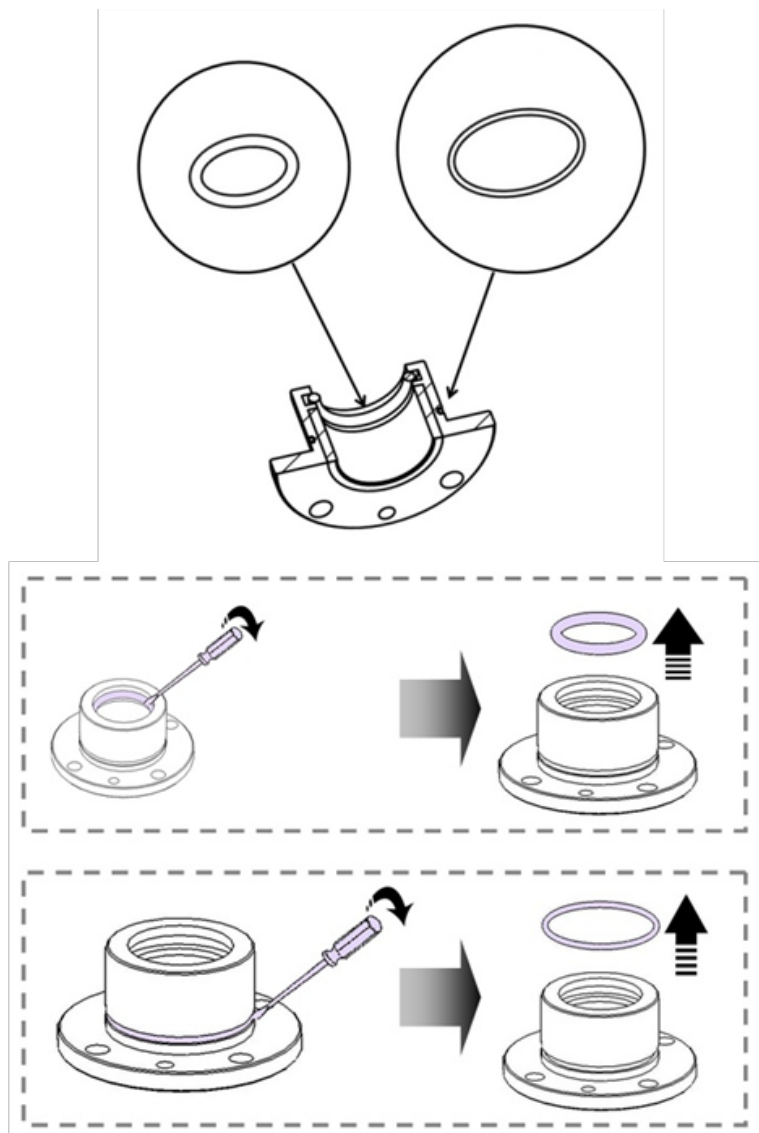

- ✓ Using a flat screwdriver, replace the seals (1) and (2).

Tools needed



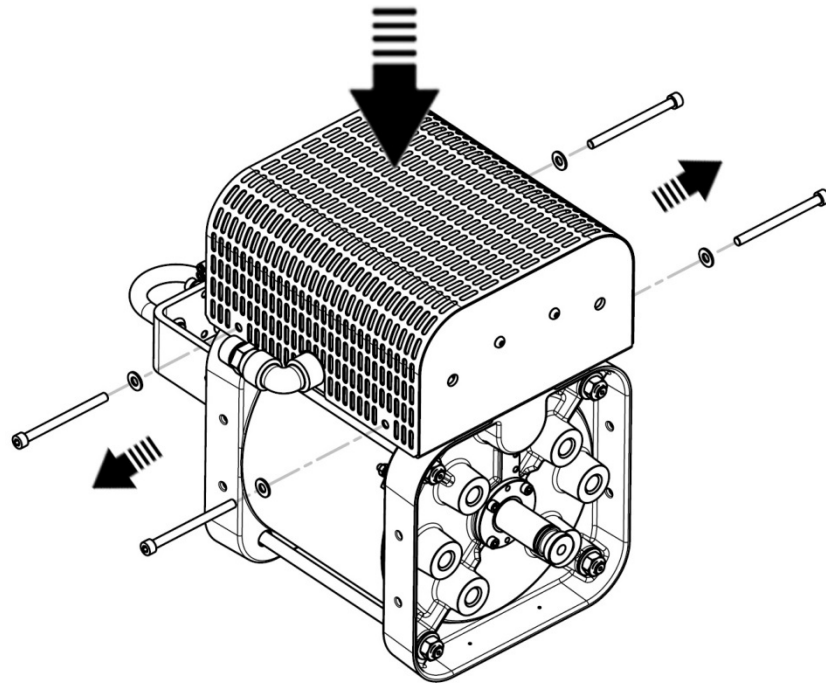

Attention

Manually maintain pressure on the sheet metal (1) before unscrewing the 4 screws.

- ✓ Remove the 4 screws with a 6 mm BTR wrench and the washers from the housing grid.

Tools needed

6



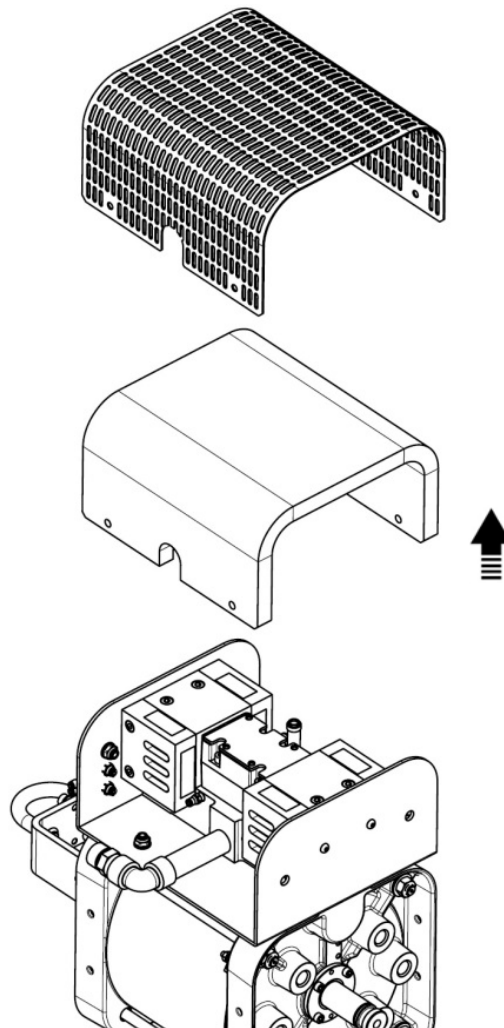

-
- ✓ Remove the crankcase and protective foam from the motor.
-

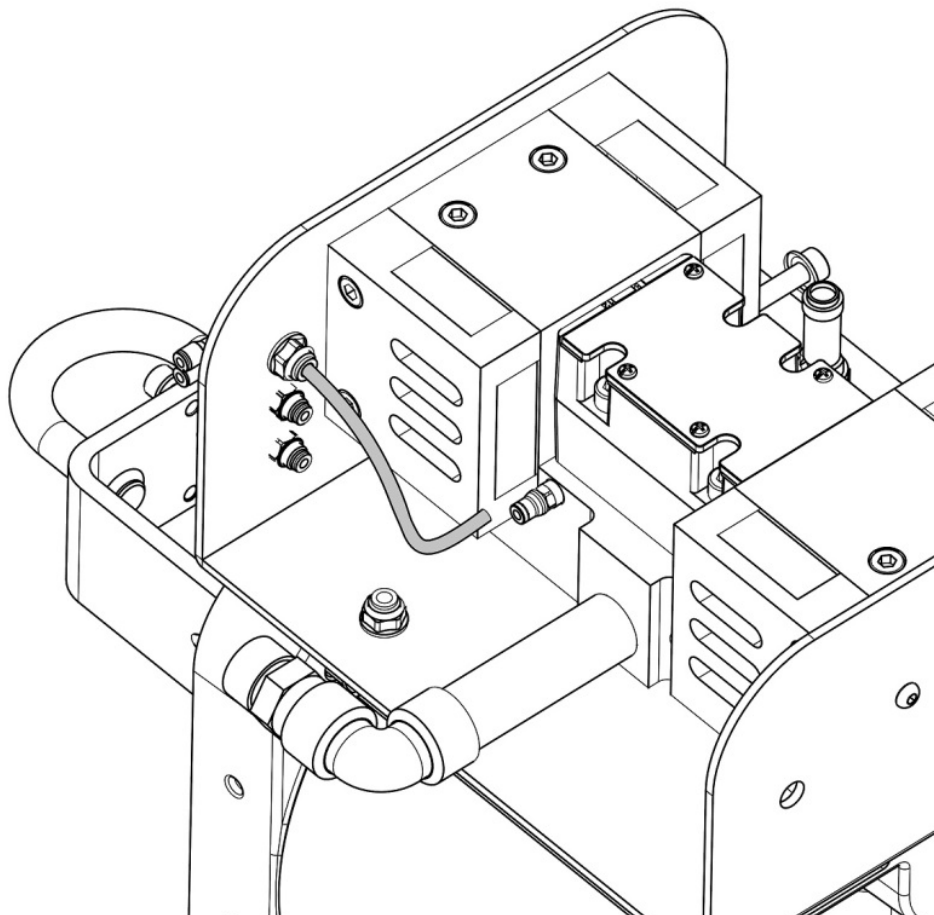

- ✓ Remove the pneumatic hoses from the distributor, leaving the bulkheads.

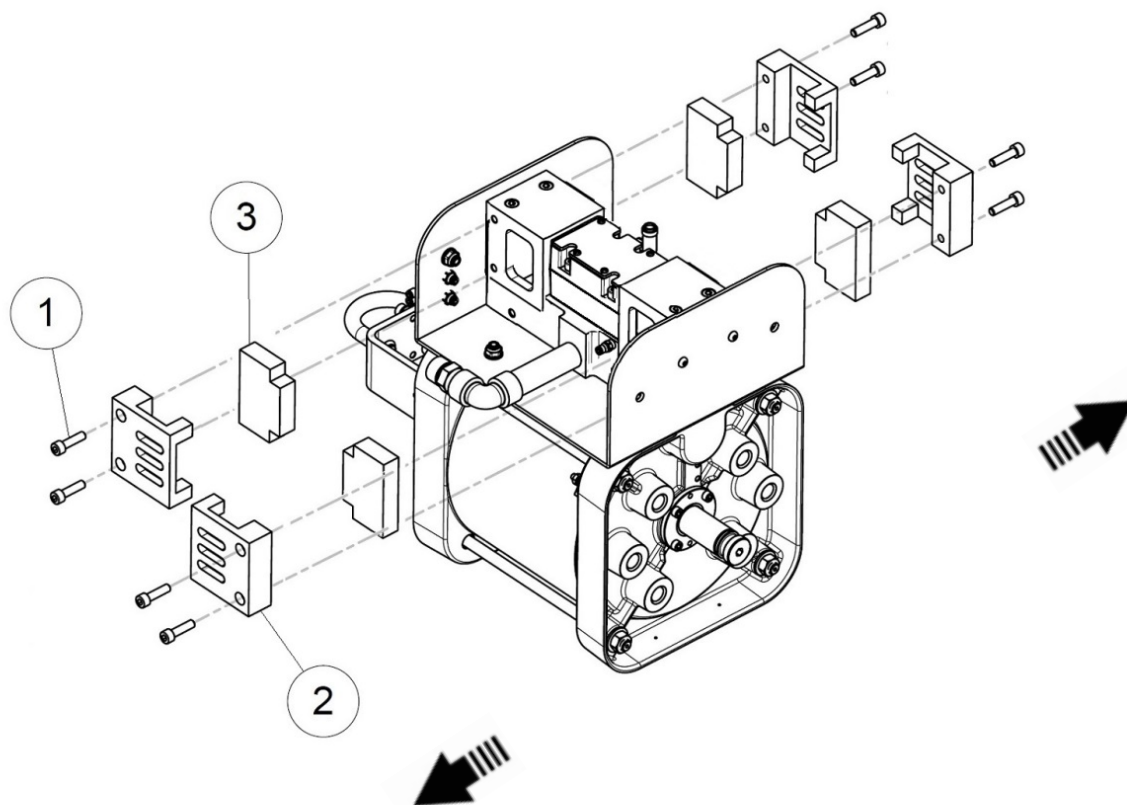

- ✓ Remove the 4 rigid foams and their holders from the distributor.

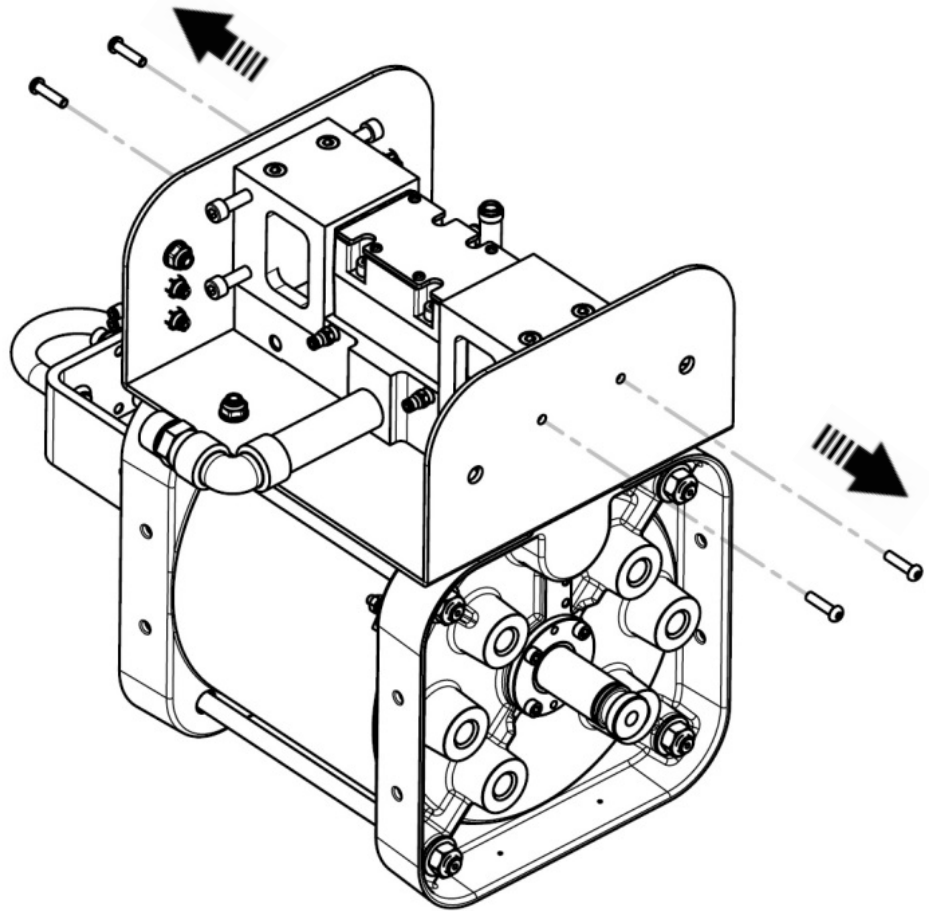

- ✓ Remove the 4 screws above and below the housing using a BTR wrench of 4 mm.

Tools needed

4 

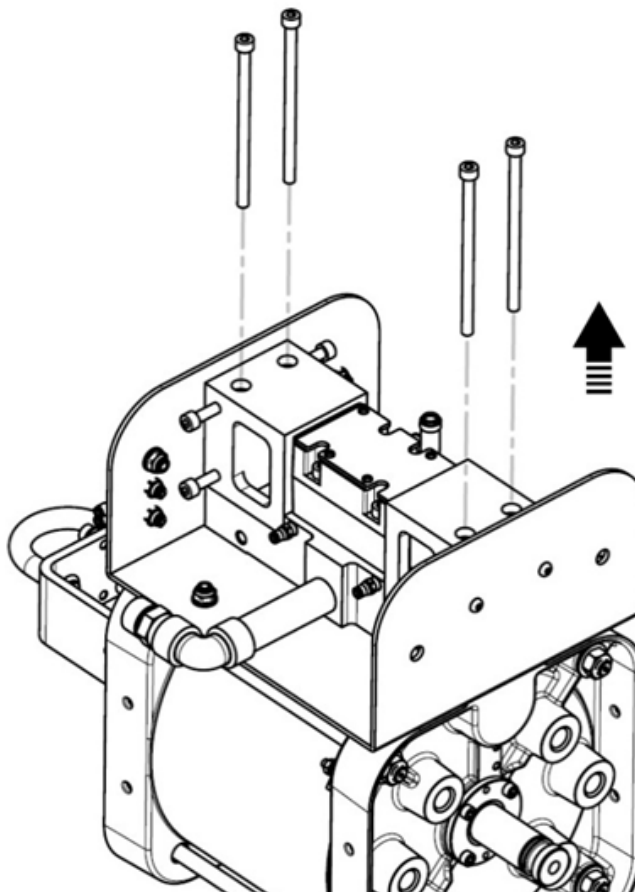

- ✓ Remove the 4 screws connecting the distributor to the housing, using a BTR wrench of 6 mm.

Tools needed

6



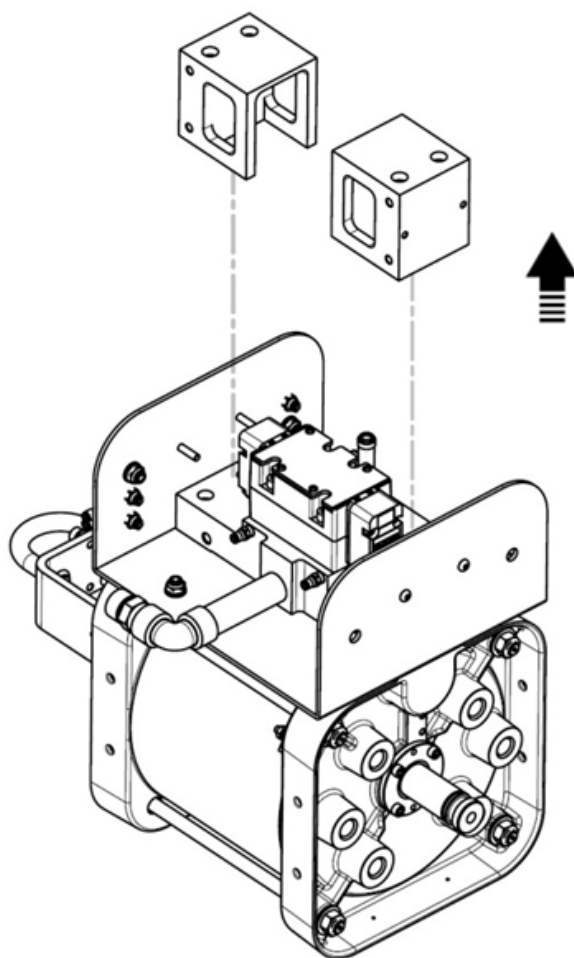

-
- ✓ Remove the two exhaust mounts.
-

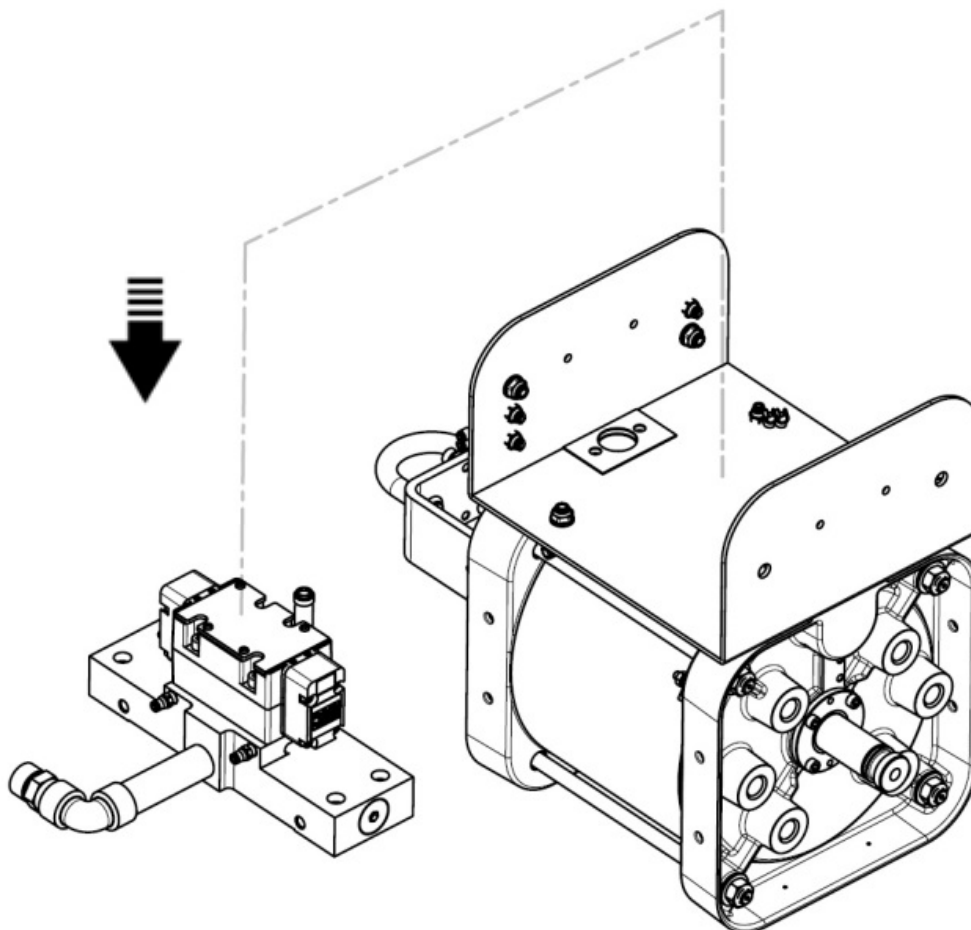

- ✓ If necessary, place the distributor assembly on a workbench for disassembly.

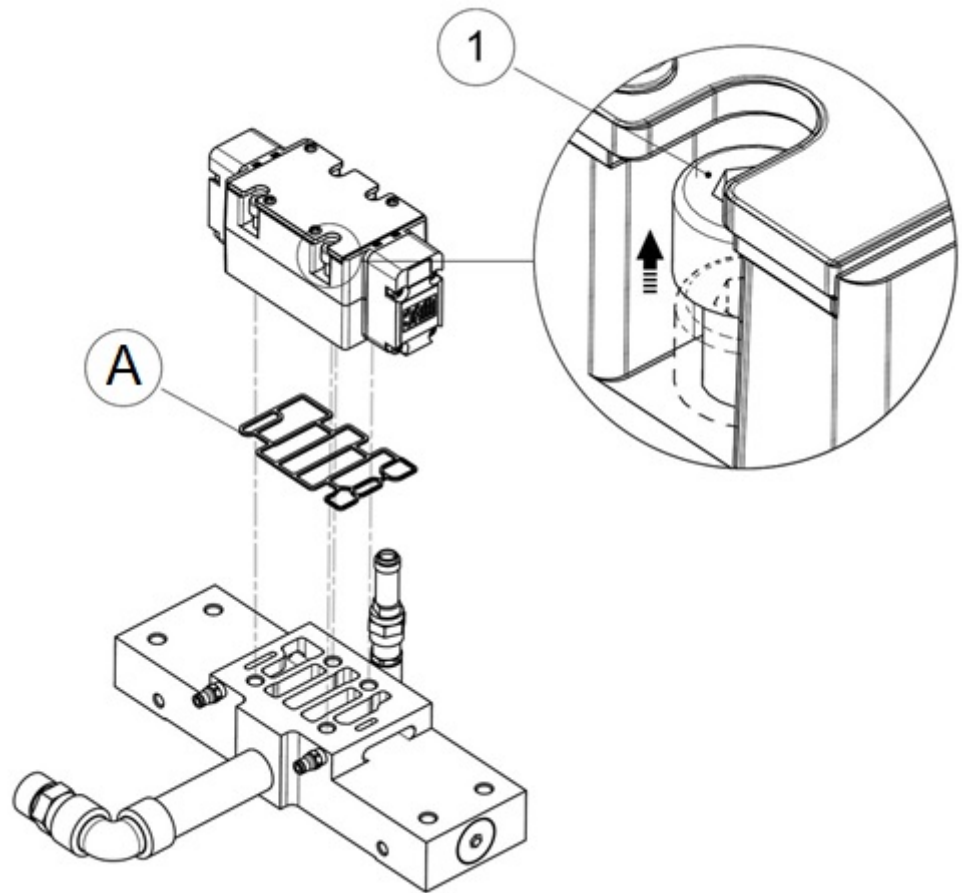

- ✓ To dismantle the distributor, remove the 4 screws using a BTR wrench of 6 mm.

Seal (A) is sold with the distributor.

Tools needed



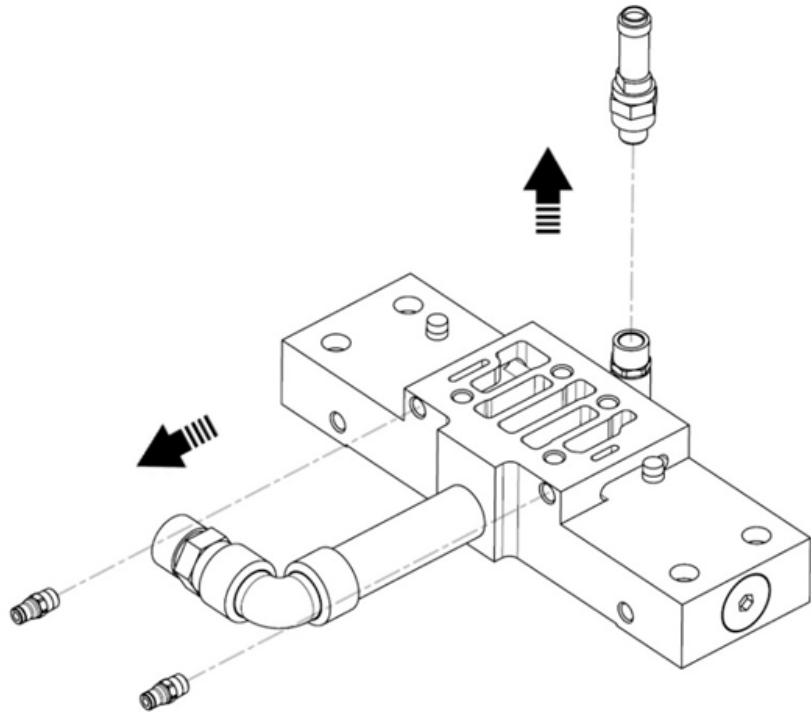

- ✓ Disassembly of the safety valve requires a spanner of 20 mm.
- ✓ Disassembly of the 2.7 / 4 pipe fittings requires a 10 mm spanner.

Tools needed

10



20



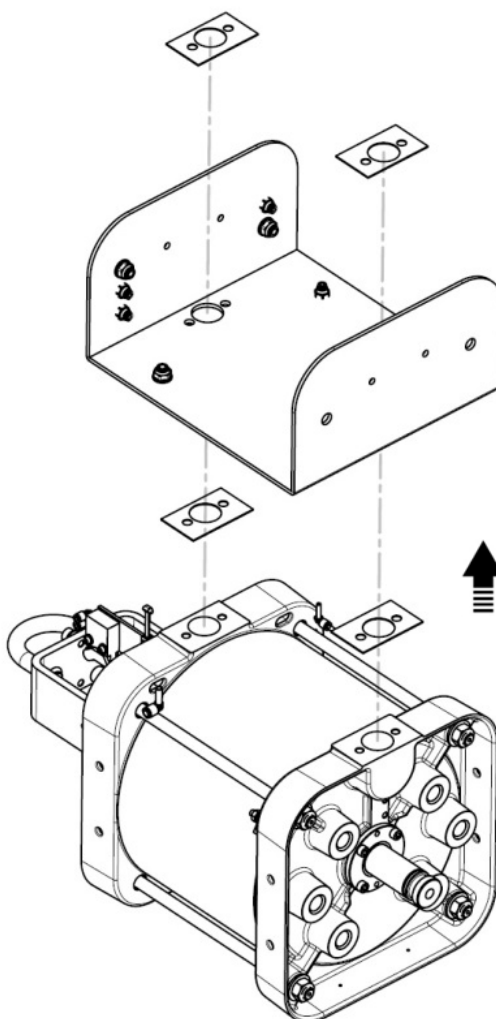

- ✓ Remove the flat gaskets, as well as the plastic sheet with the assembled bulkheads.

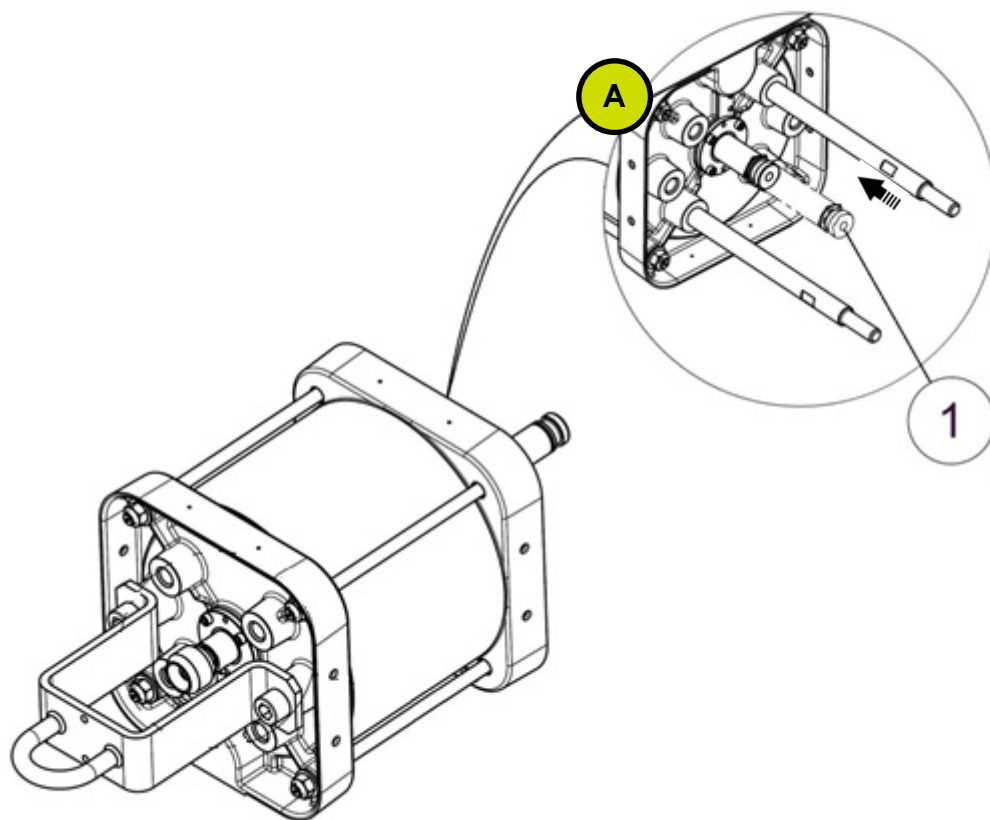

- ✓ (A) If necessary, manually retract the motor rod to adjust its position.

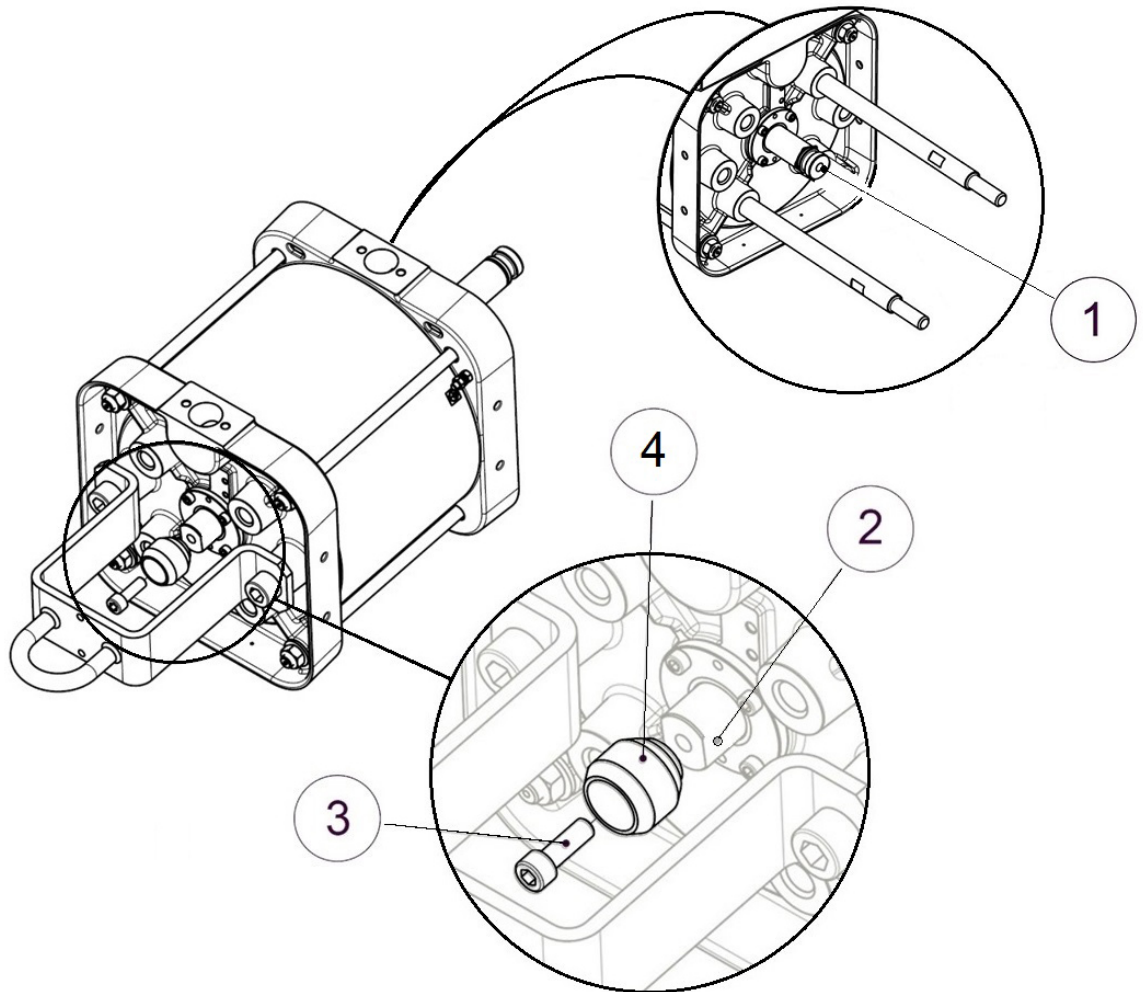

- ✓ To unscrew the cam, hold the rod (1) with an 8 mm BTR wrench.
- ✓ Unscrew the screw (3) with an 8 mm BTR wrench and manually remove the cam (4).

Tools needed

8 x2 

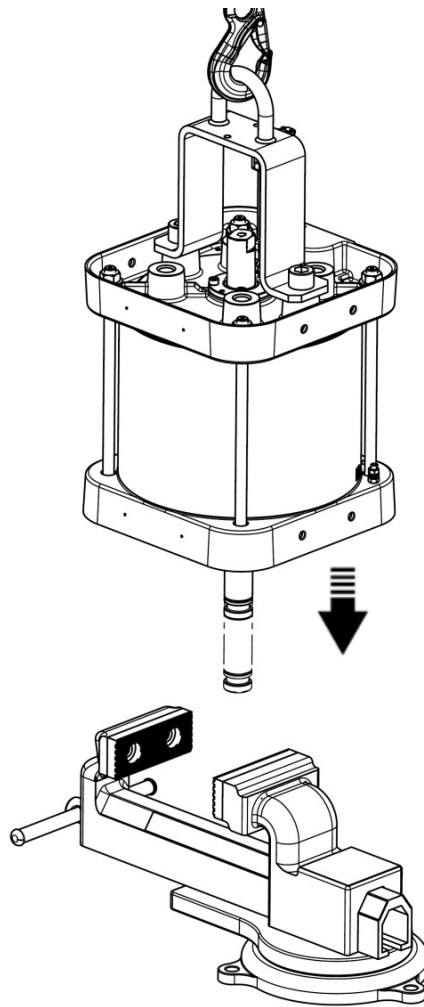

- ✓ Using the slings, approach the motor in a vertical position above a suitable vice.



Attention

in vertical position, the motor rod falls down by gravity.

Tools needed



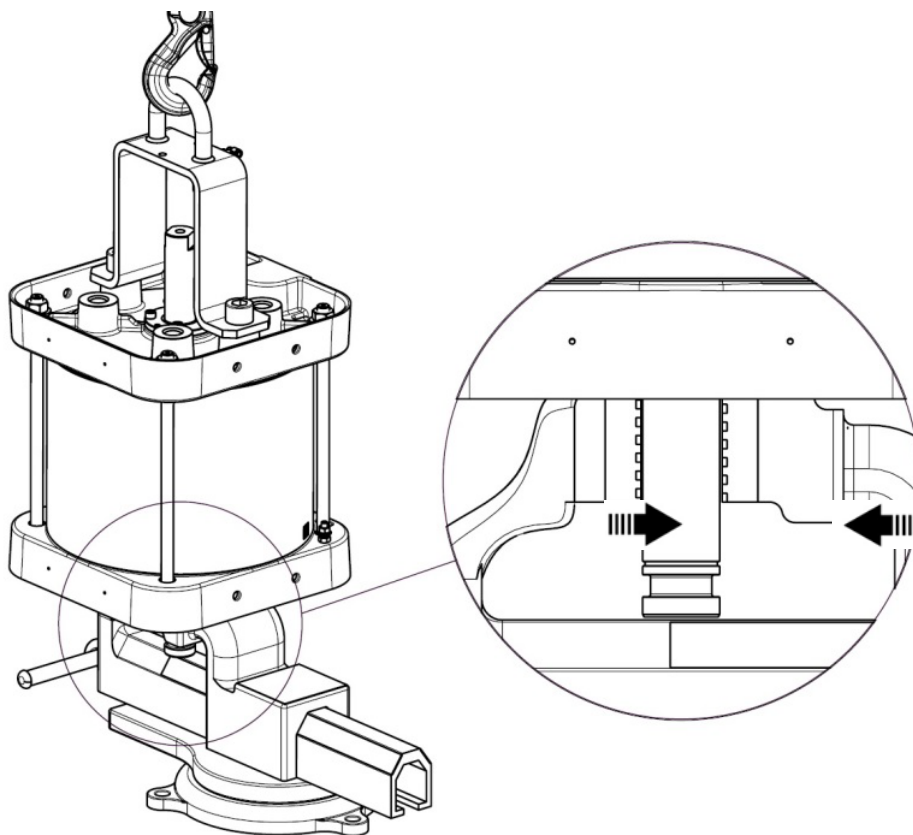

- ✓ Remove the motor from the vice, so that the lower flange rests on the jaws of the vice and the rod is locked in the jaws.



Attention

If the vice does not have a soft jaw, use a cloth to avoid damaging the rod coating.

- ✓ Remove the slings.

Tools needed



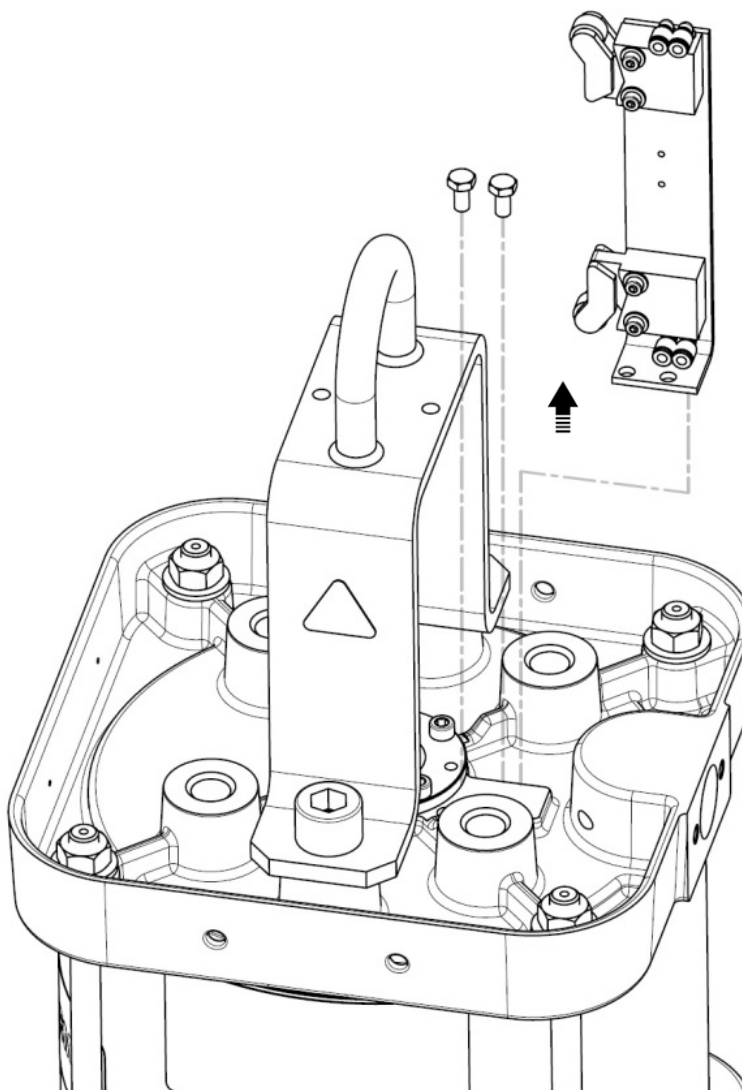

- ✓ Remove the bracket with the switches and the 5/2 bistable distributor, unscrewing the two screws at its base with a 10 mm open-end wrench

Tools needed



10



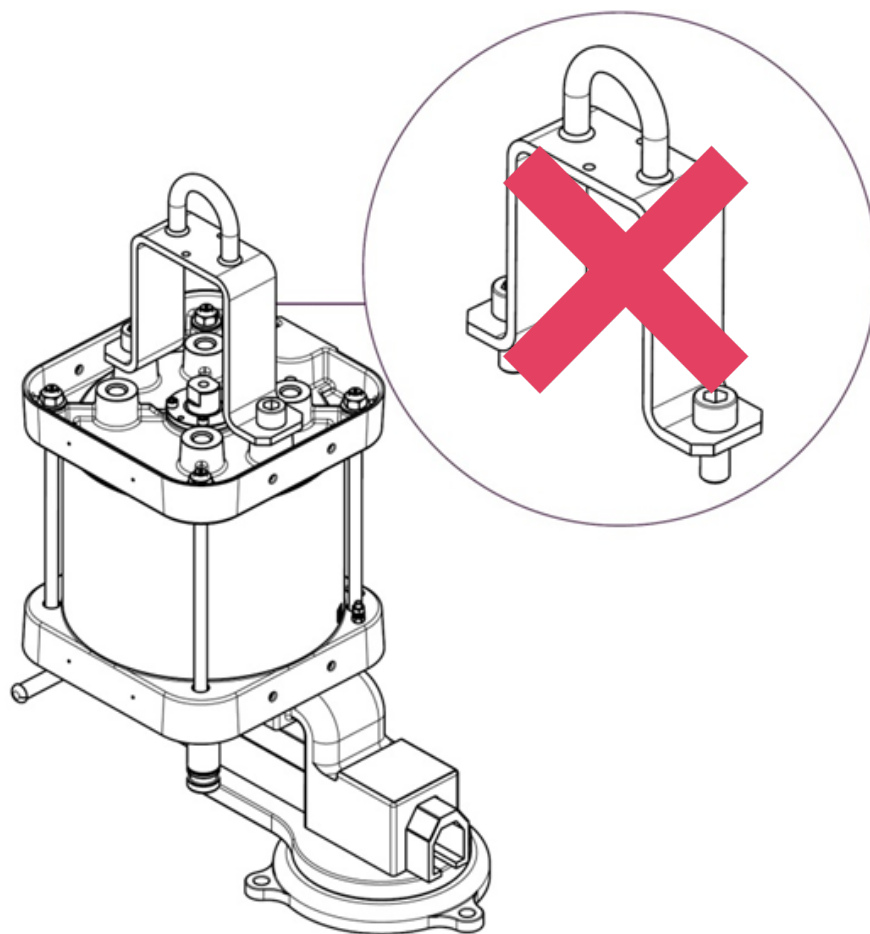

Attention : it is strongly discouraged to remove the caliper, the tightening torque required for its installation being very high.

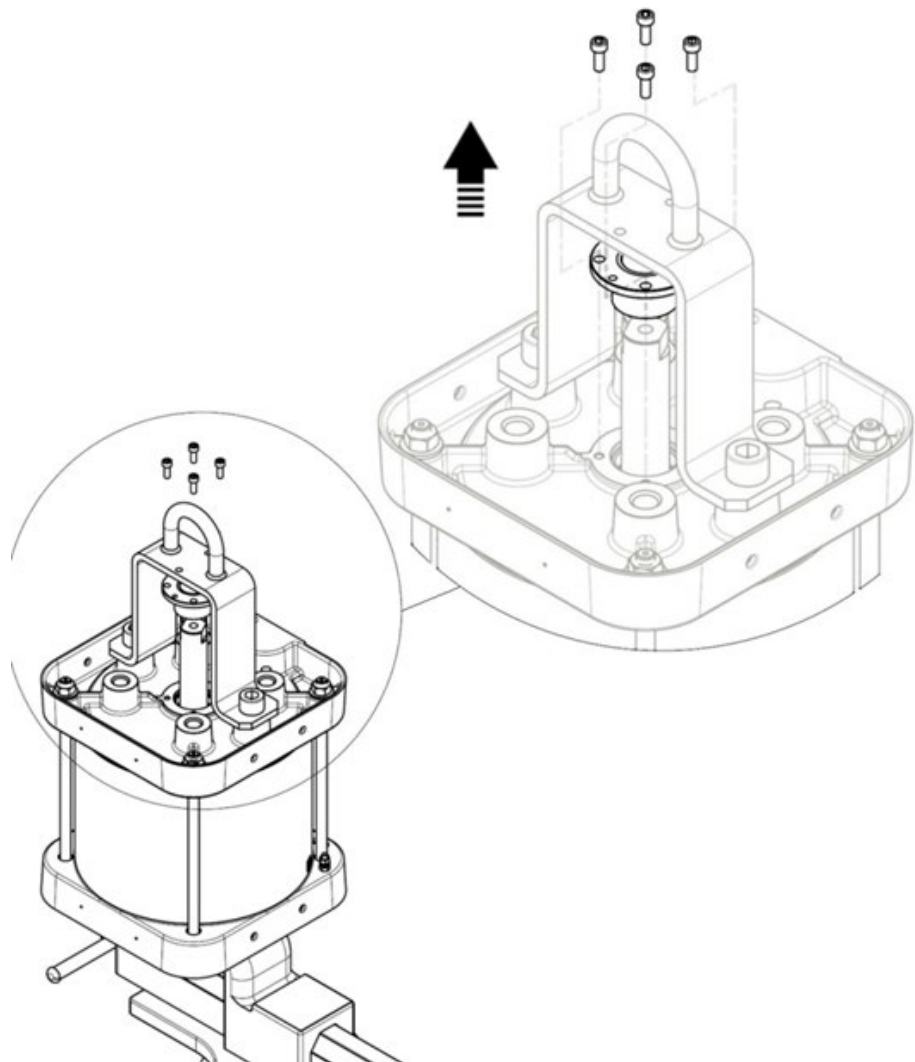

- ✓ To change the seals, disassemble the upper bearing by removing the 4 screws with a BTR key of 5 mm.

Tools needed



5



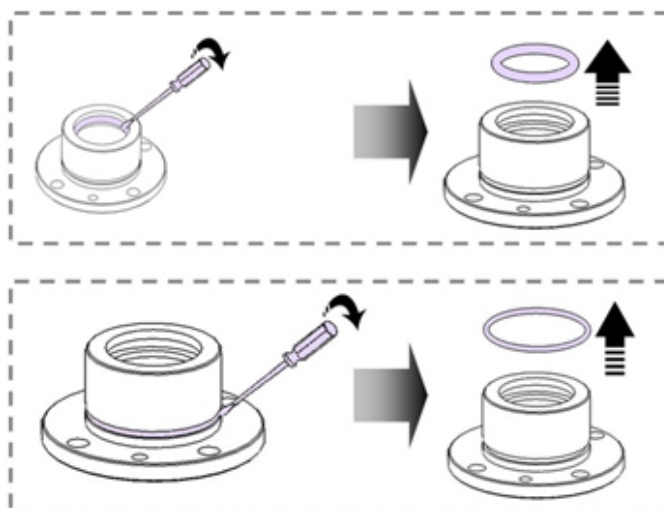
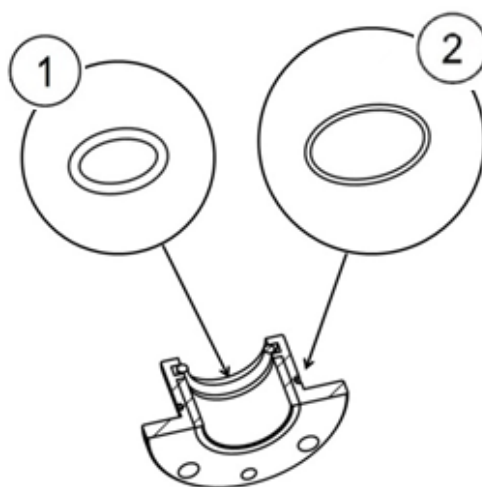

- ✓ Using a flat screwdriver, change the seals (1) and (2)

Tools needed

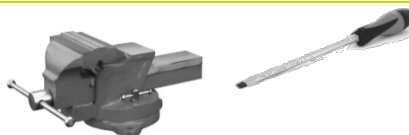

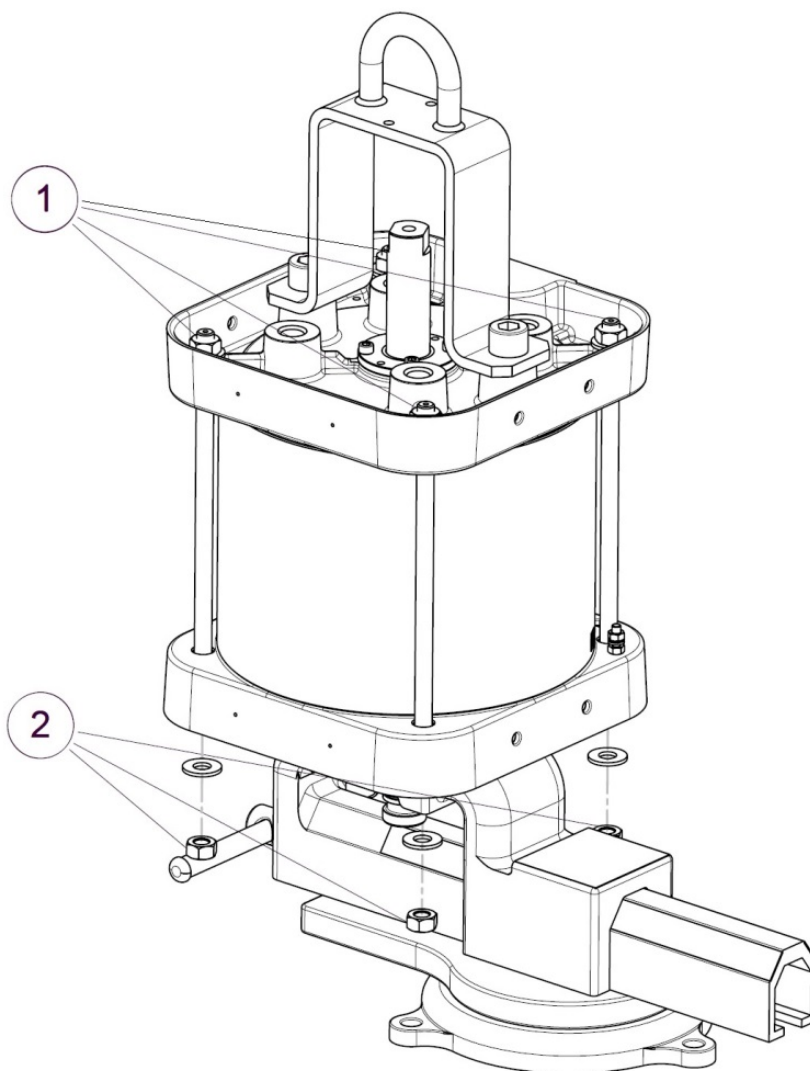

- ✓ Successively release each rod from the motor, holding the top nut (1) with a 19 mm socket wrench, while removing the corresponding bottom nut and washer assembly (2) with the other wrench.



Attention : be careful not to do the opposite operation that causes the stems to fall at the same time.

Tools needed



19x2



X2

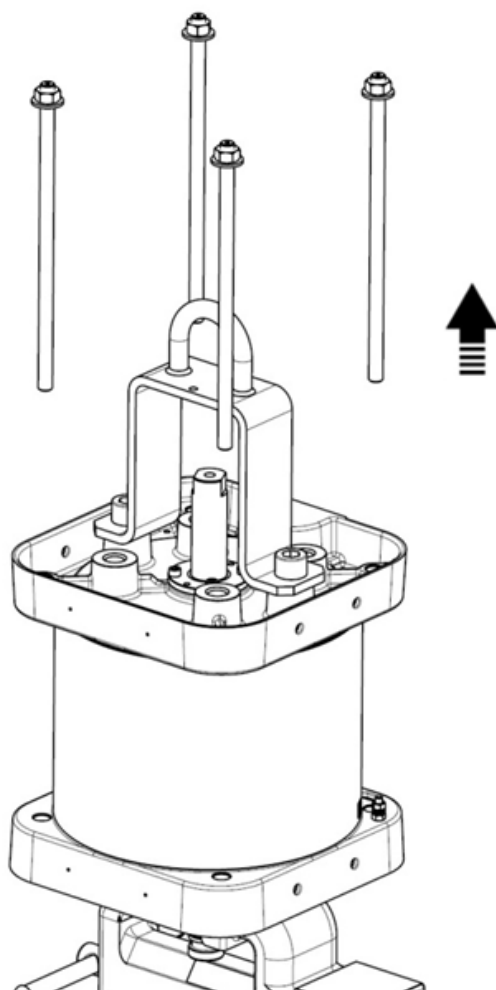

✓ Remove the 4 rods from the motor.

Tools needed



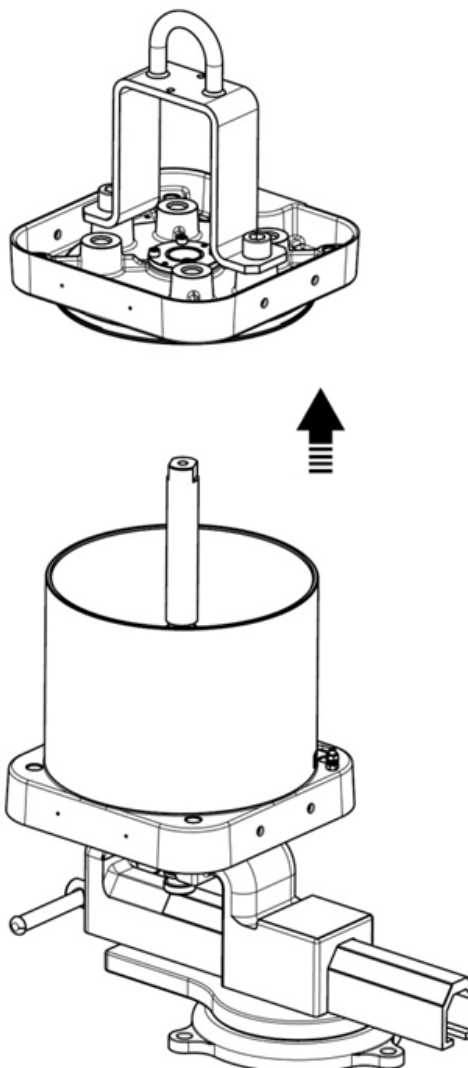

- ✓ Remove the top flange of the motor by locating its position.

Tools needed



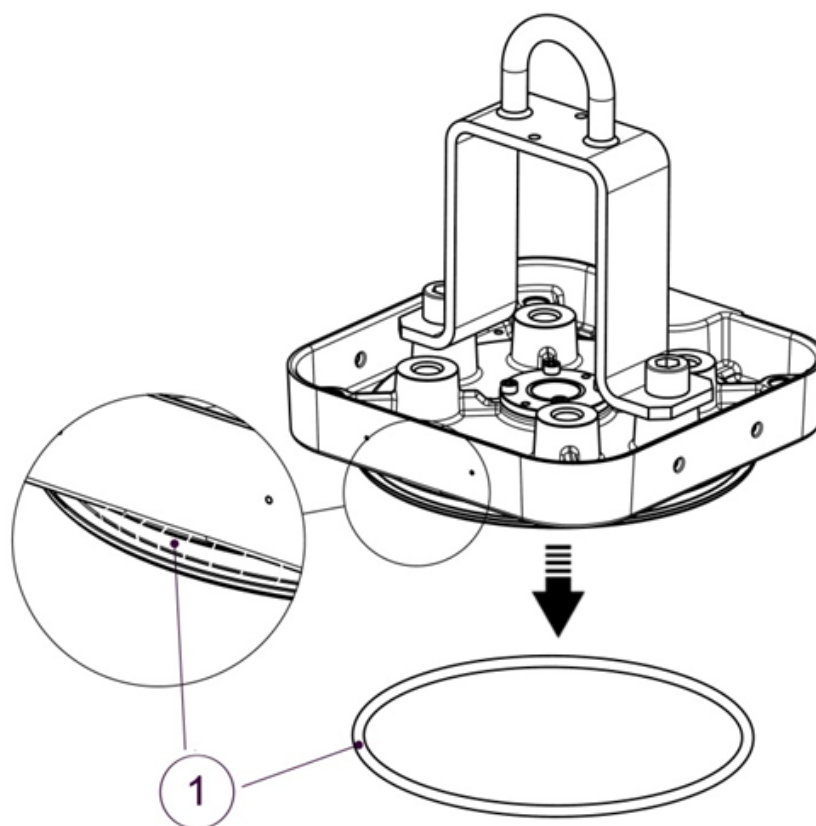

- ✓ To replace the seal (1) of the upper flange of the motor, remove it manually using a flat screwdriver.

Tools needed



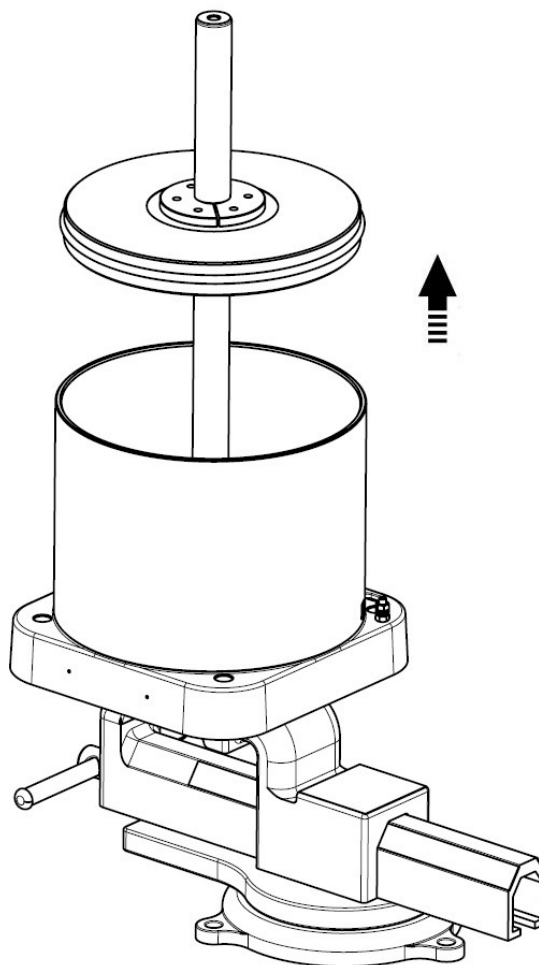

- ✓ Loosen the vice and remove the rod and motor piston assembly.

Note : it is normal for the seal to float in the piston groove between the piston and the cylinder.

Tools needed



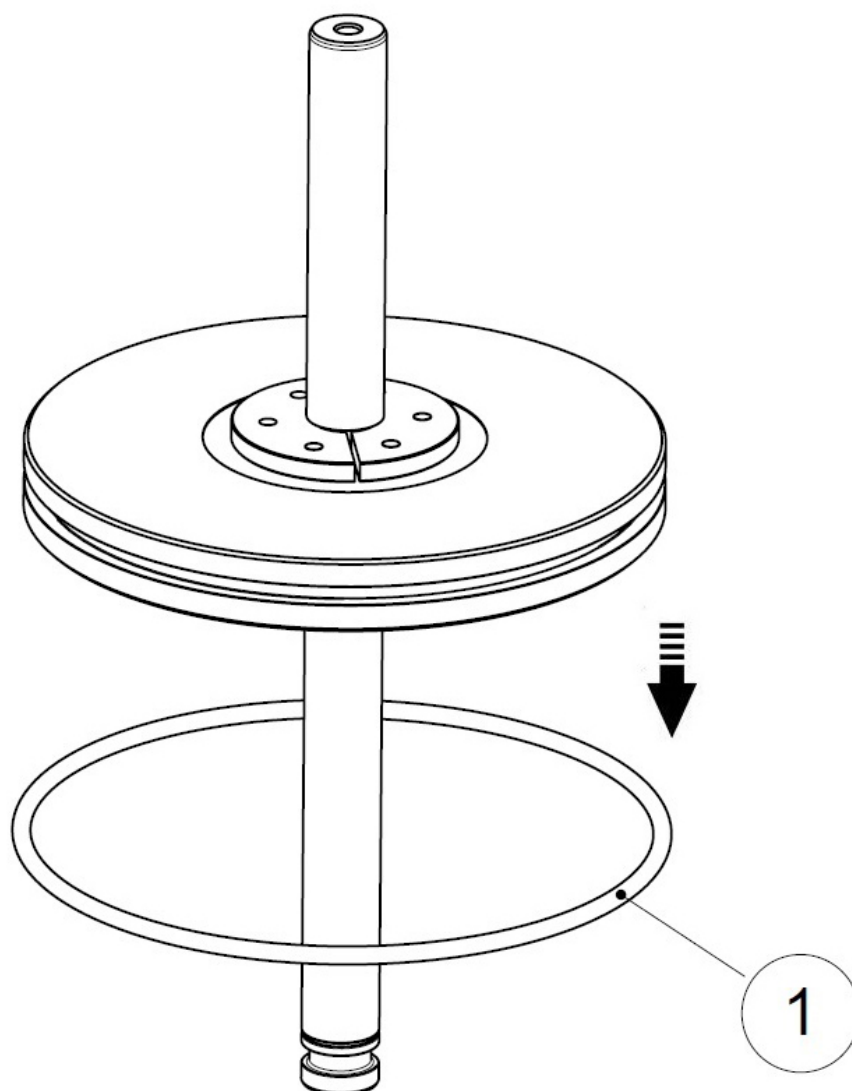

- ✓ Retrieve the piston seal.

Tools needed



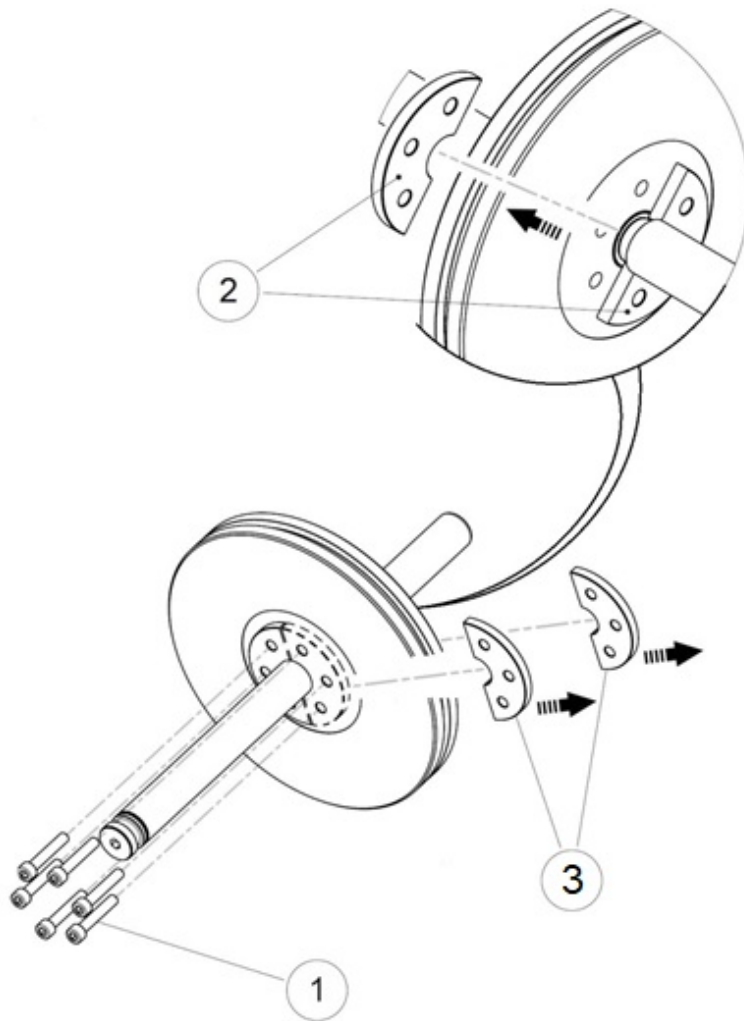

- ✓ To replace the stem seal, first unscrew the 6 screws with a BTR key of 6 mm, to remove the two upper and two lower flanges.

Note: mark the mounting direction of the counter flanges.

Tools needed



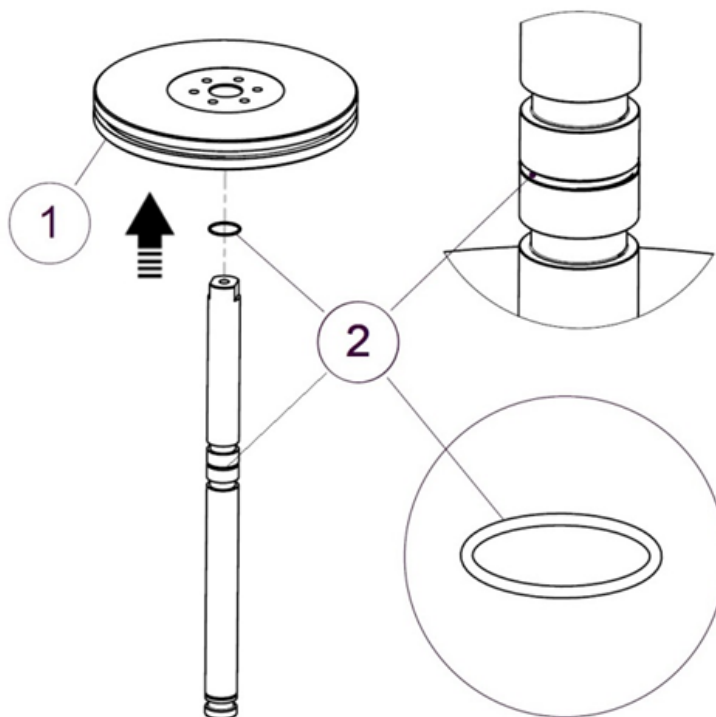

- ✓ Remove the piston (1), then remove the seal (2) using a flat screwdriver.

Tools needed



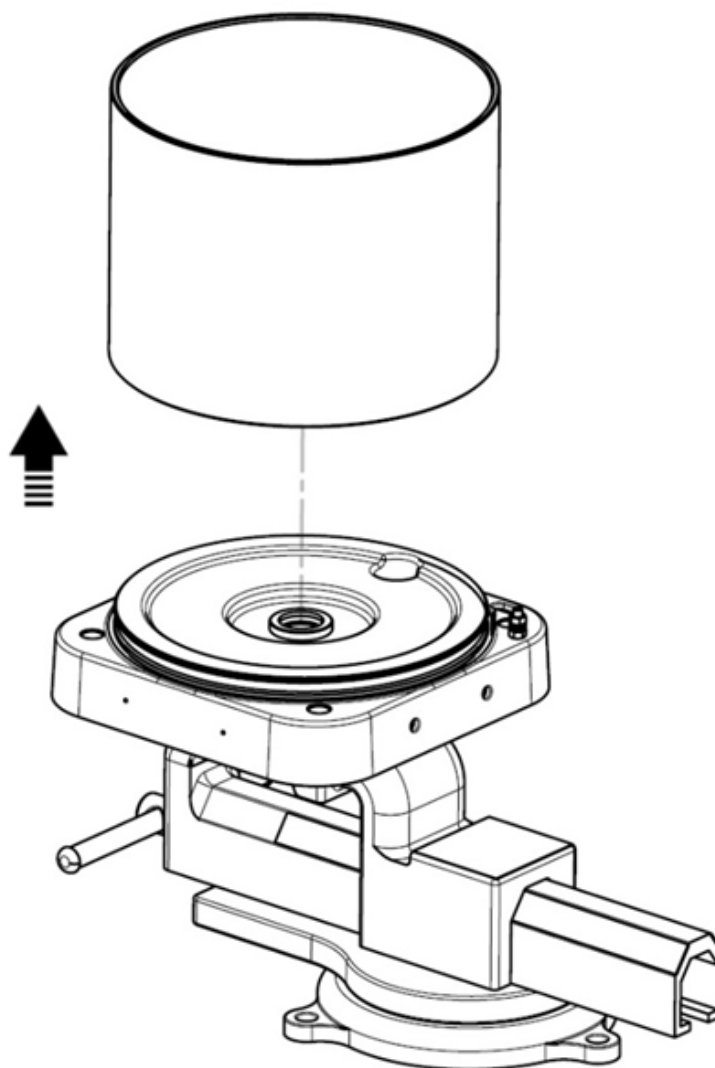

- ✓ Manually remove the cylinder from the lower flange.

Tools needed



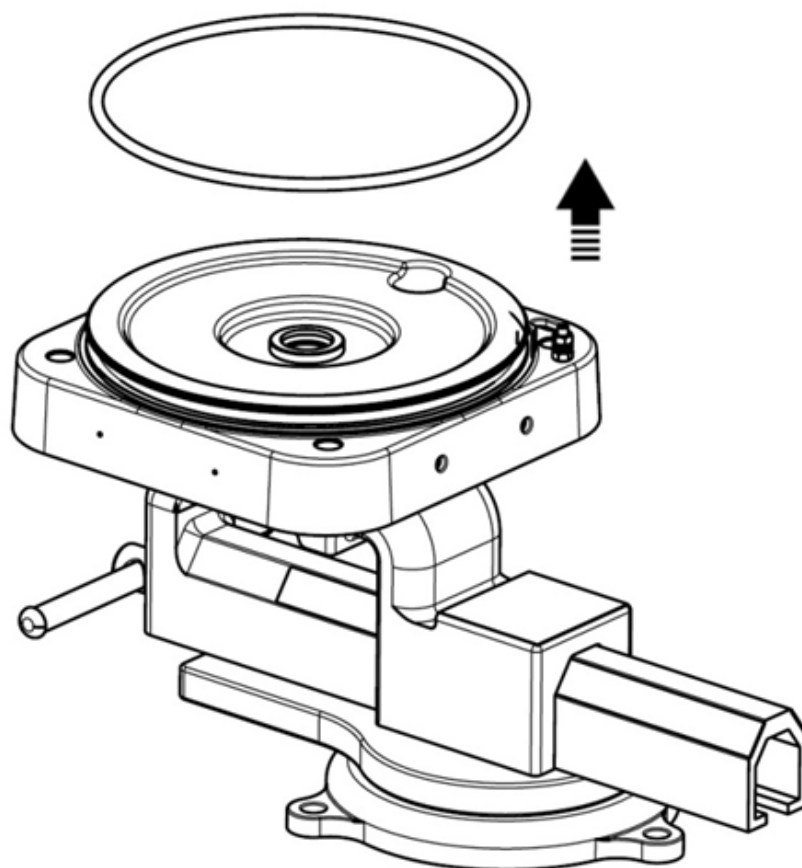

- ✓ Remove the gasket from the lower flange using a flat screwdriver.

Tools needed



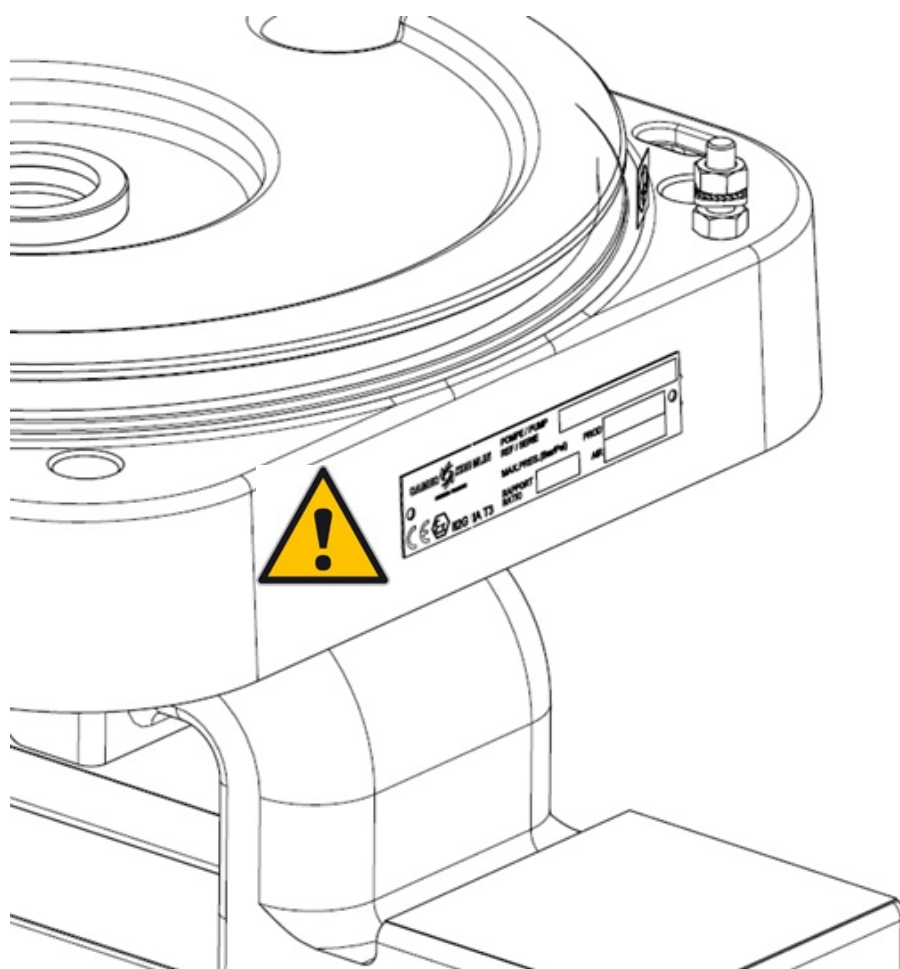

Attention: never disassemble the plate of firm of the equipment present on the lower flange.

14.3 Reassembly



ATTENTION :

The procedure described below requires the use of a vice and a workbench.

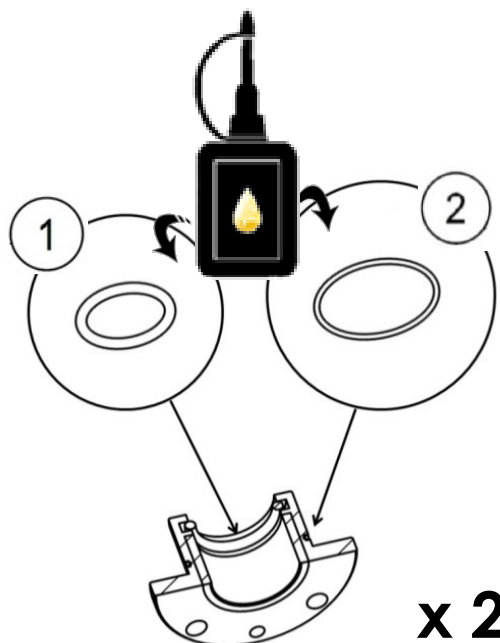

- ✓ Place seals (1) and (2) in their respective locations on the motor bearing.
- ✓ Grease the entire joint contour evenly with industrial grease.

Tools needed



**Kluber petamo
HY 133N**

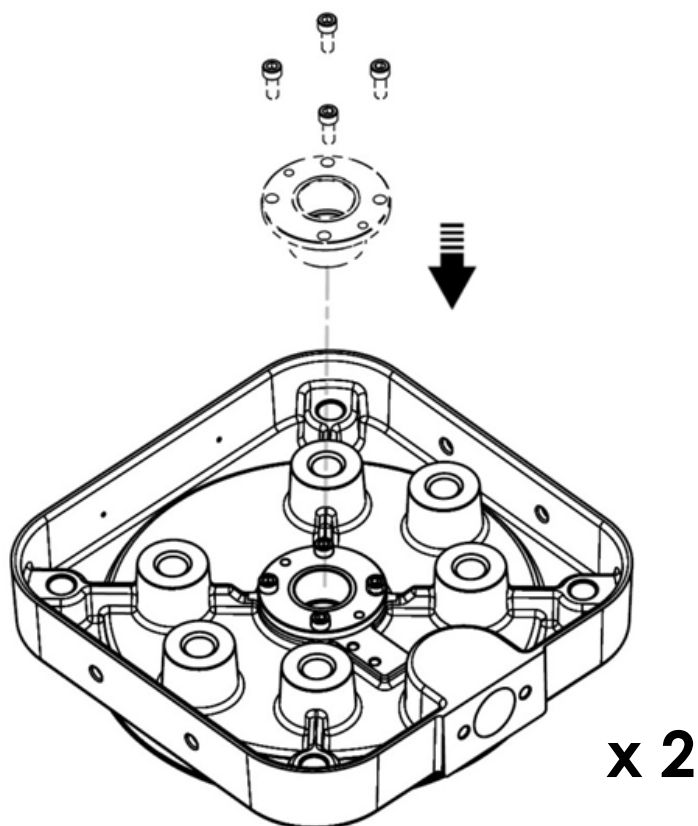

- ✓ Place the engine bearing fitted with greased seals in each of the two flanges.
- ✓ Screw the 4 screws connecting each bearing to the corresponding flange (upper and lower), using a BTR key of 5 mm.

Tools needed

5 

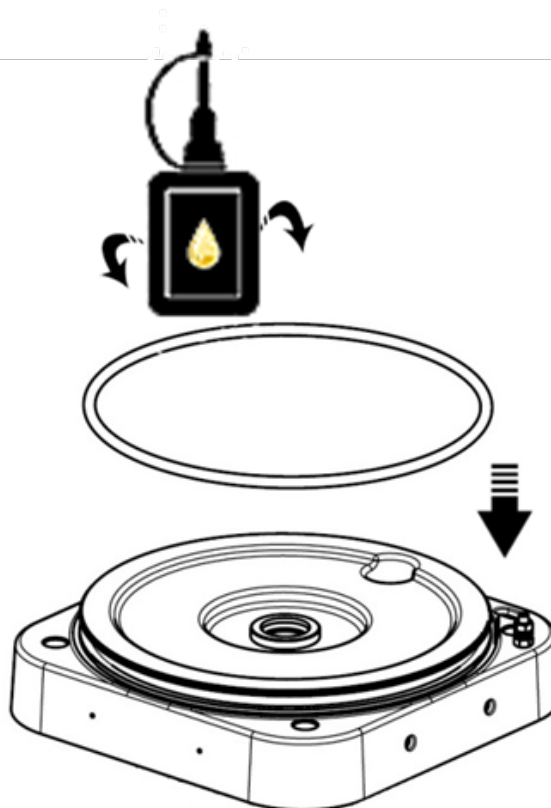

- ✓ Fit the gasket on the flange and lubricate evenly over the entire joint contour with the industrial grease.

Tools needed



**Kluber petamo
HY 133N**

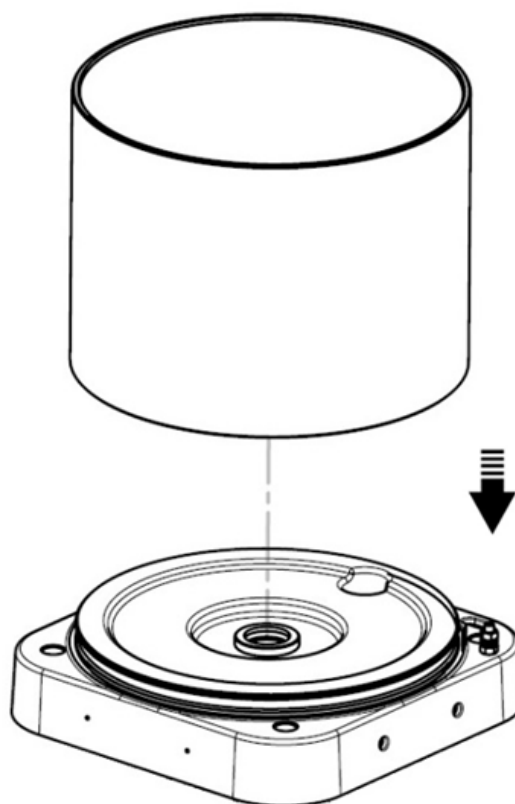

- ✓ Place and insert with a mallet the motor cylinder on the lower flange.
- ✓ The cylinder must come into abutment on the flange.
- ✓ Grease the inside of the cylinder evenly over the entire contour.

Tools needed

**Kluber petamo
HY 133N**

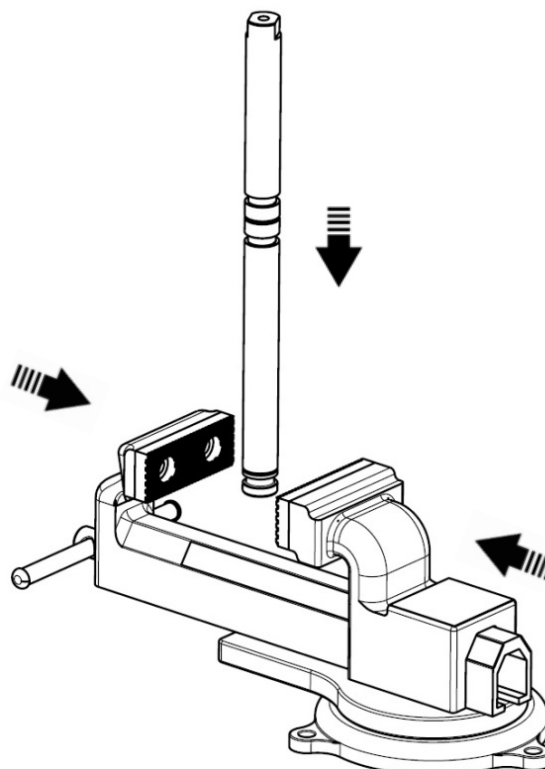

- ✓ Place the motor rod (lower part) in a V-jaw vice (protect this rod so as not to damage it).



Attention

If the vice does not have a soft jaw, use a cloth to avoid damaging the rod coating.

Tools needed



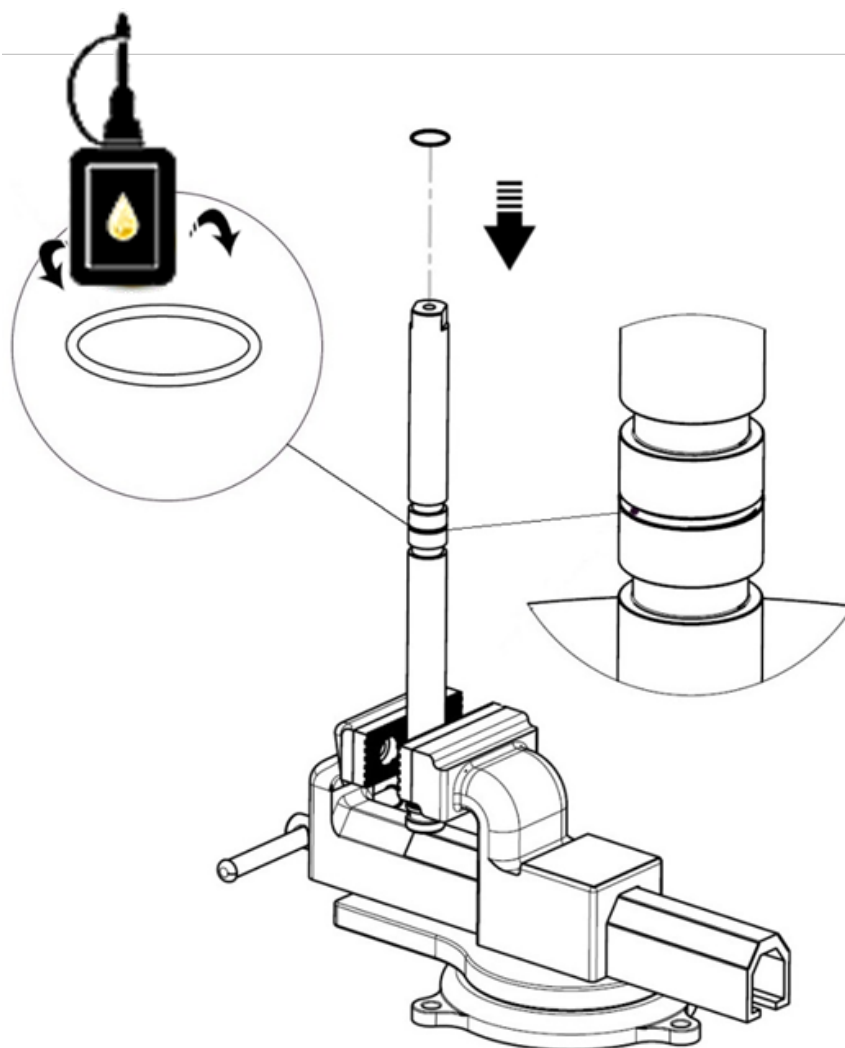

- ✓ Place the seal on the motor rod.
- ✓ Grease the seal.

Tools needed



**Kluber petamo
HY 133N**

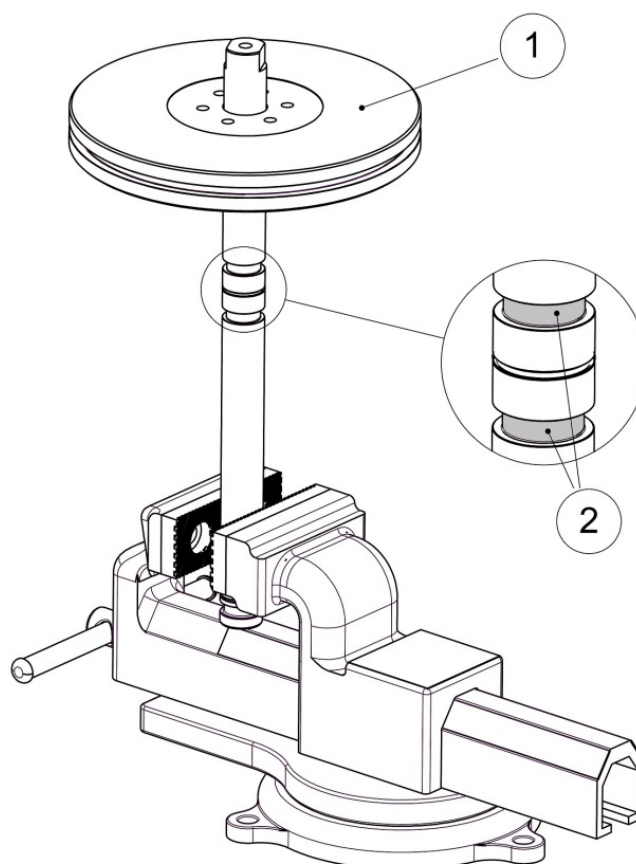

- ✓ Press the motor piston onto the motor rod (1) and place the piston between the two grooves (2) of the rod. It must cover the seal.

Tools needed

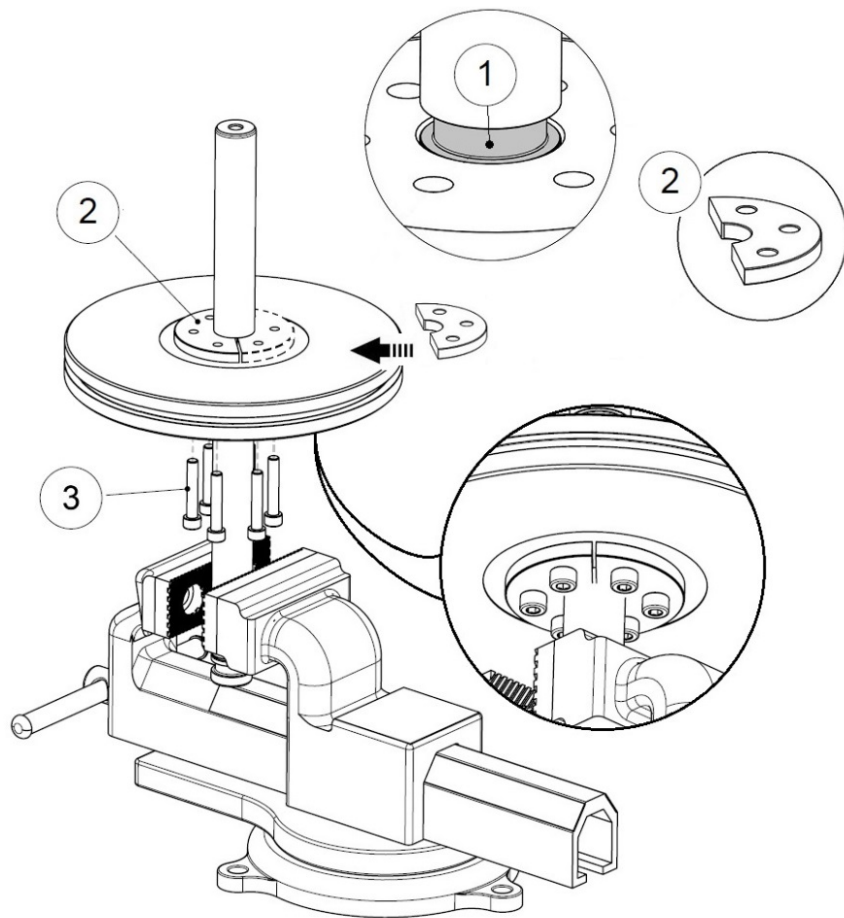

- ✓ Place the counter flanges (2 and 4) and glue them in the grooves (1) of the drive rod (pay attention to the direction),
- ✓ Screw and glue (anaerobic adhesive low threadlock) the 6 screws CHC M8X45 (3) with a key BTR of 6 mm.
- ✓ Wipe off excess glue.



Attention

Pay attention to the mounting direction of the counterflanges.

Tools needed

6



Loxal 58-31



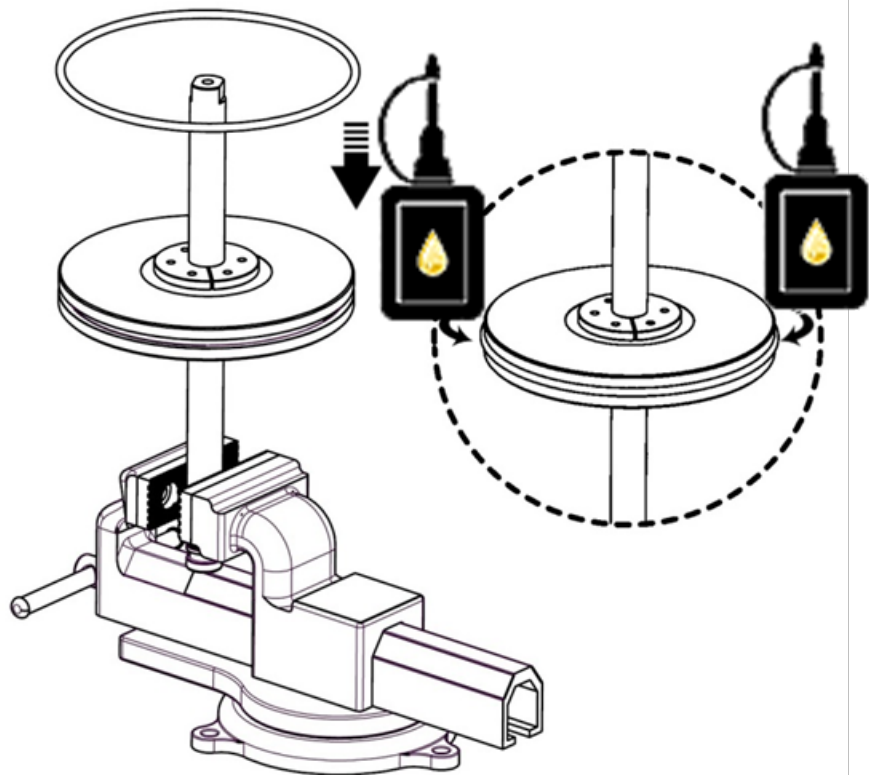

- ✓ Place the floating seal in the groove of the motor piston.
- ✓ Then lubricate it evenly over the entire contour.

Note: It is normal for the seal to float in the piston groove between the piston and the cylinder.

Tools needed



**Kluber petamo
HY 133N**

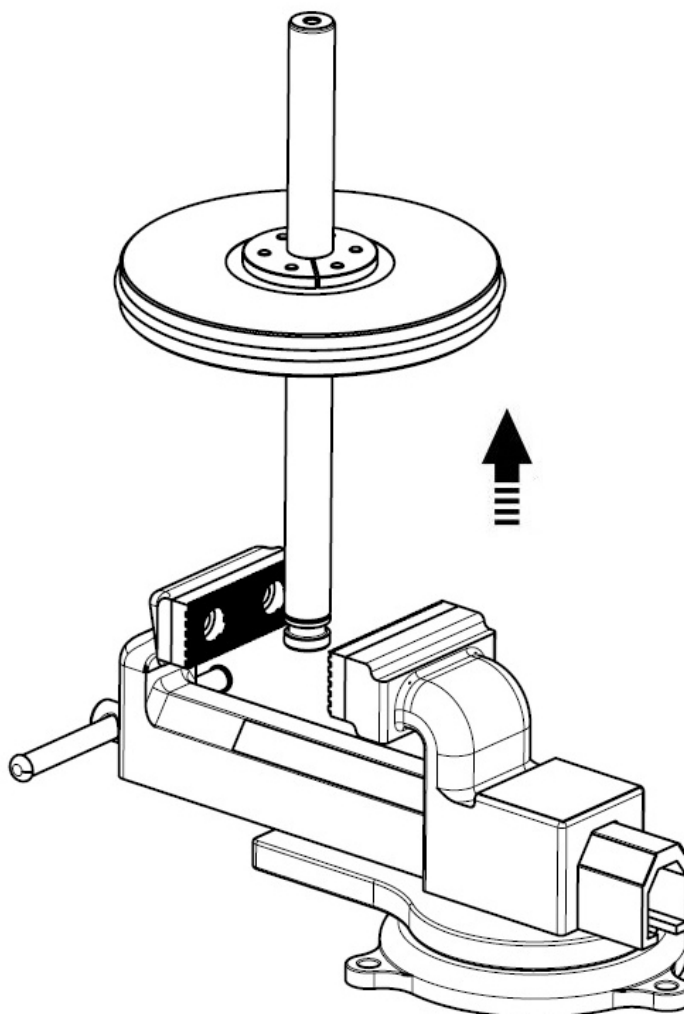

- ✓ Undo the vice, lift and place the rod and piston assembly on a bench.

Tools needed



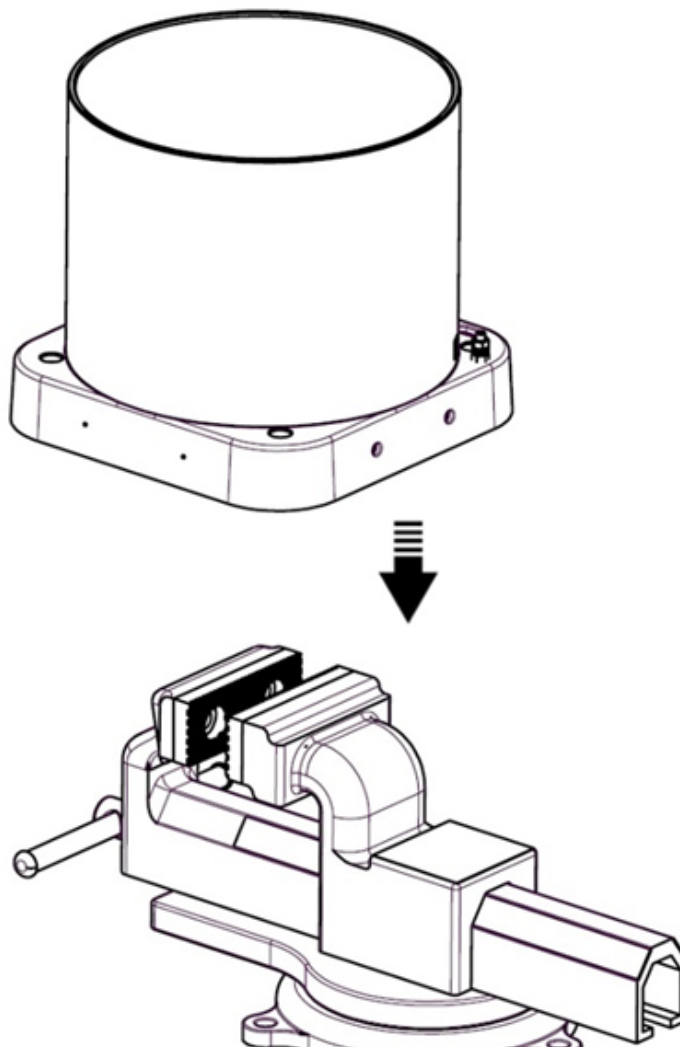

- ✓ Place the lower flange and motor cylinder assembly on the open bench vice by positioning the rod above the crosshead of the vice.

Tools needed



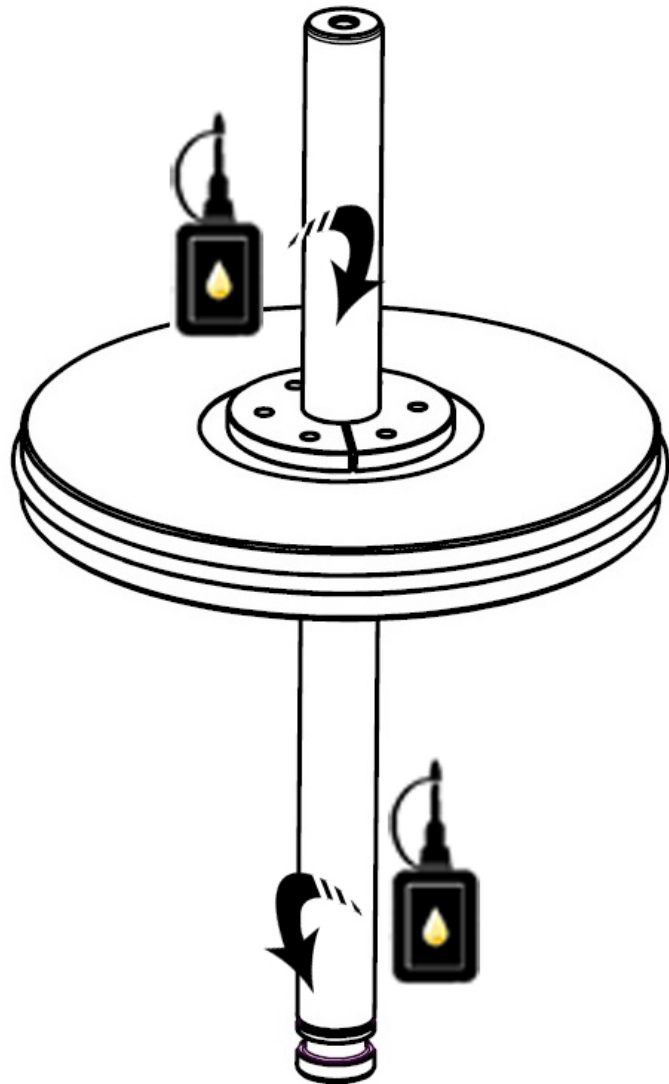

- ✓ Take up the rod and piston assembly with the lifting means through the lifting eye,
- ✓ Evenly grease the entire height of the rod circumference.

Tools needed



**Kluber petamo
HY 133N**

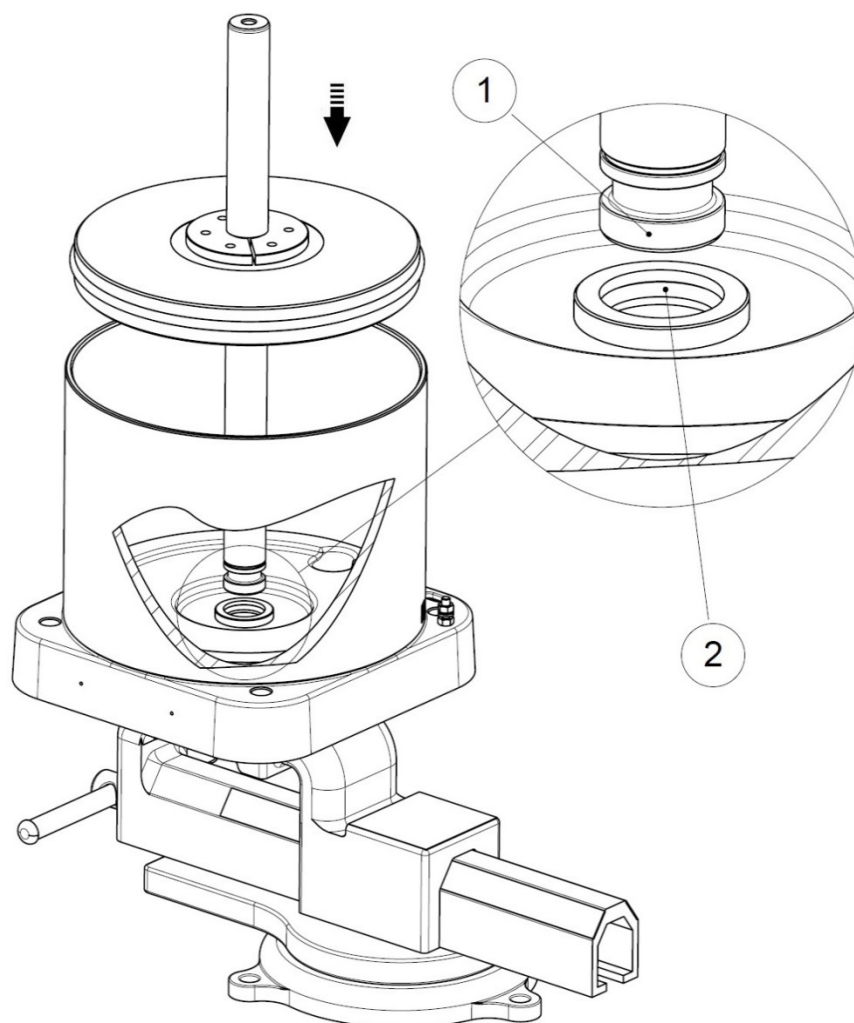

- ✓ From above, position the rod (1) in the bronze bearing (2) of the motor bearing and SLOWLY lower the rod + piston assembly.

Tools needed



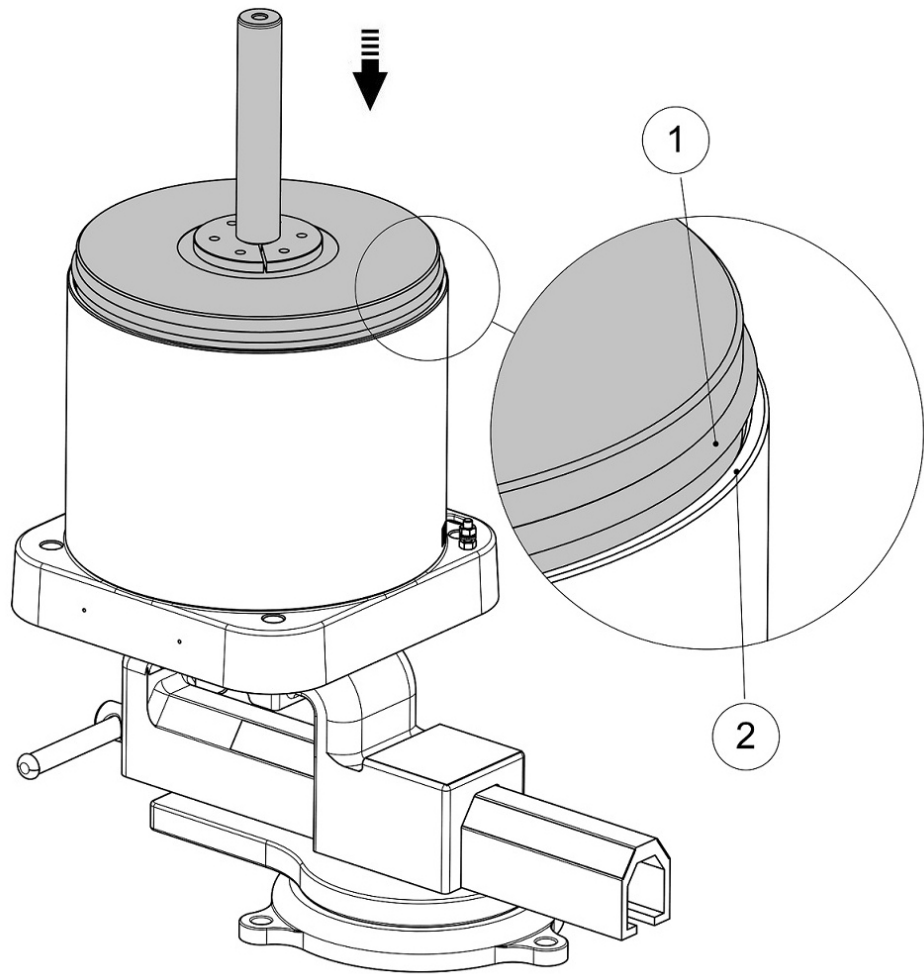

- ✓ Gently bring the floating seal (1) of the rod and piston assembly into contact with the upper edge (2) of the cylinder.

Tools needed



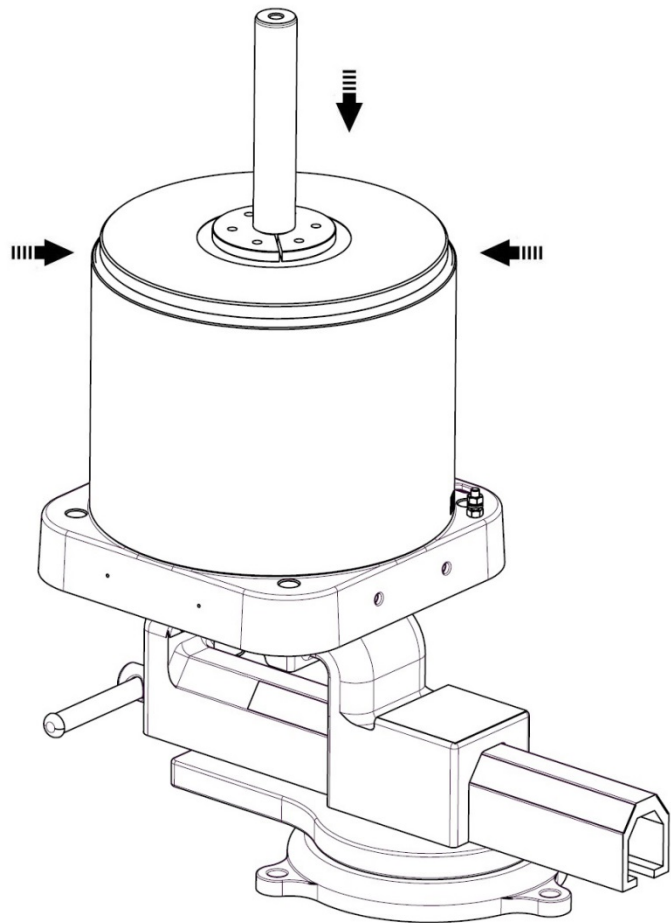

- ✓ Place the seal in the motor cylinder by guiding it manually along the entire contour of the cylinder.



Attention

Risk of pinching

Tools needed



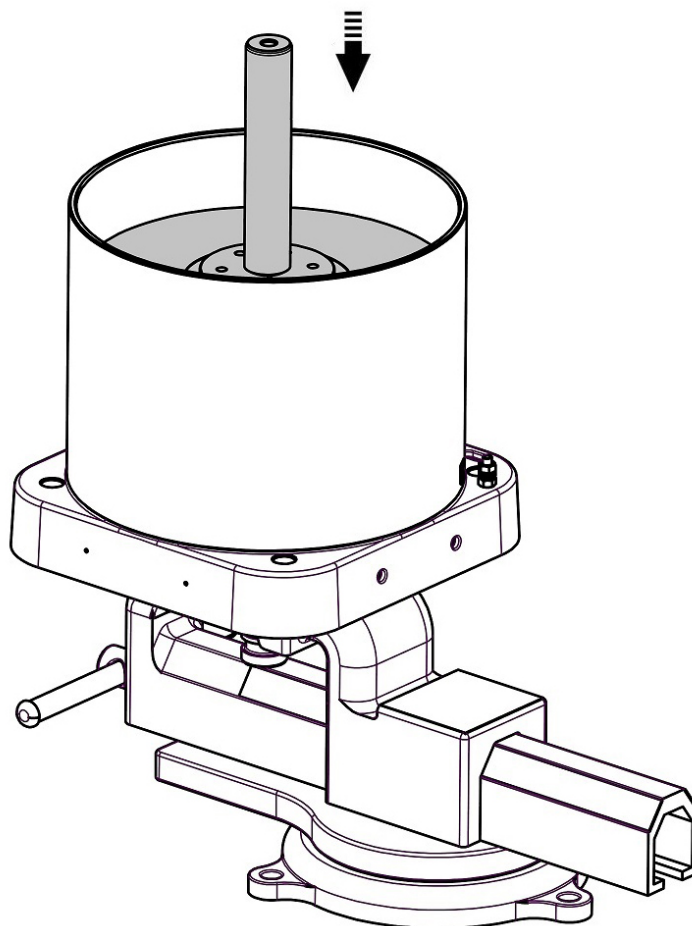

-
- ✓ Lower the rod and piston assembly to the end of the lower flange of the motor or the vice.
-

Tools needed



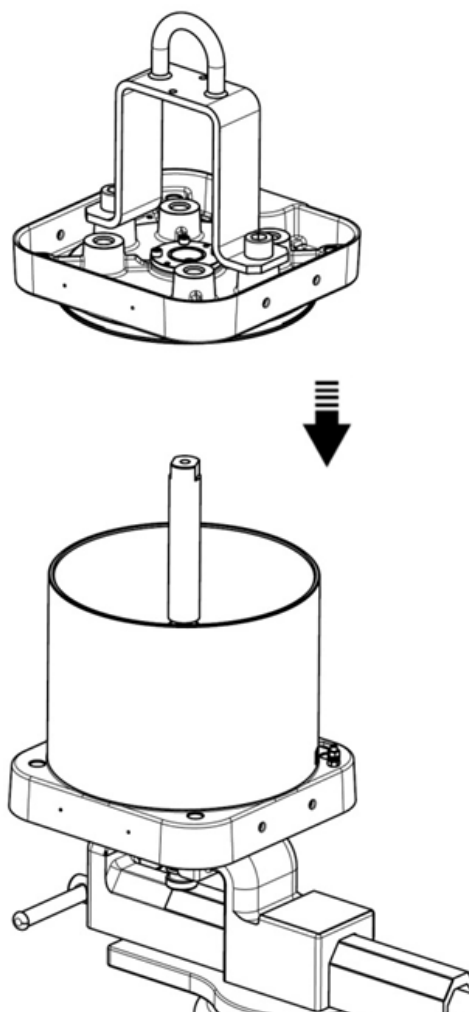

- ✓ Place and fit with a mallet the upper flange equipped (with stirrup), until the stop. (Attention to the direction of assembly).

Tools needed

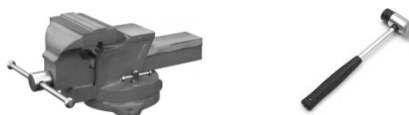

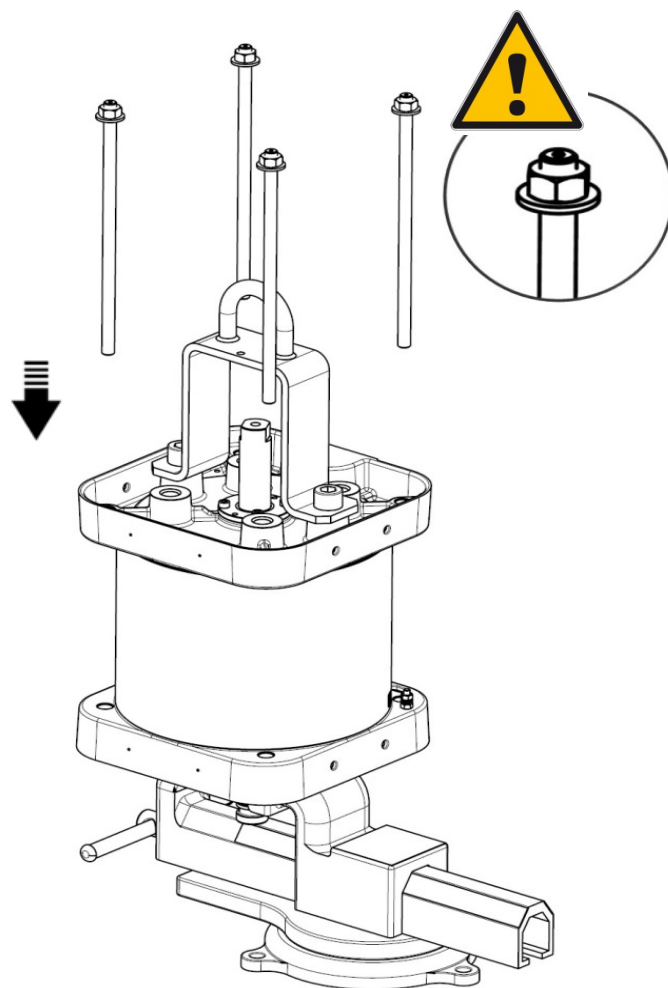

- ✓ Place the 4 tie rods + nut on the motor, from above, and on the lower part, place the washers + nut on the tie rods.

Tools needed



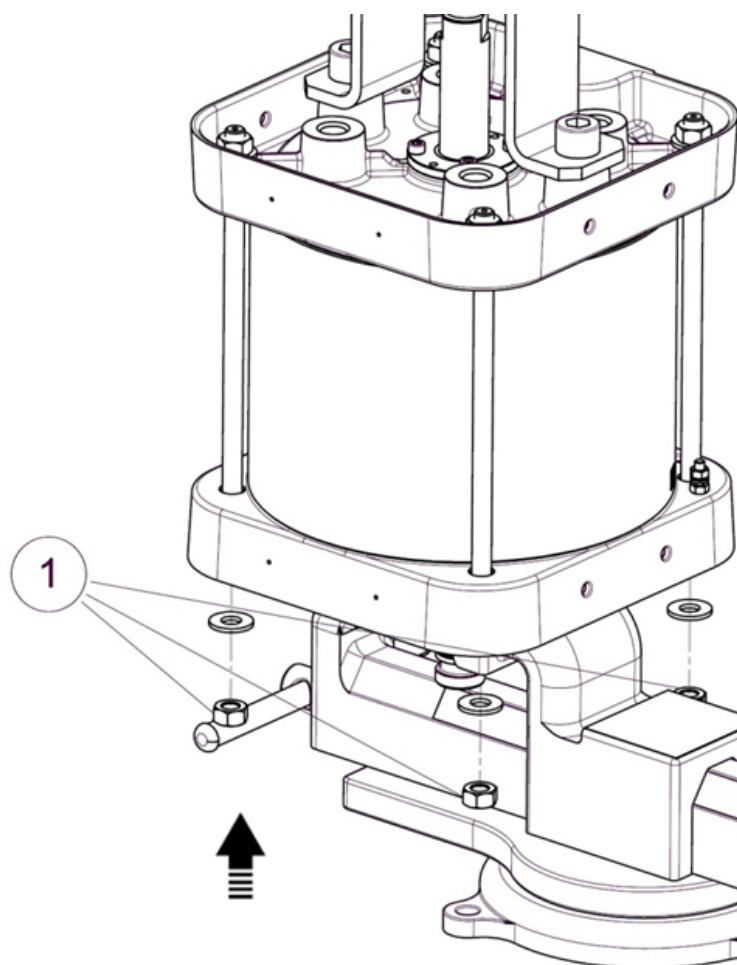

✓ MANUALLY tighten the nuts (1) as far as they will go.

Tools needed



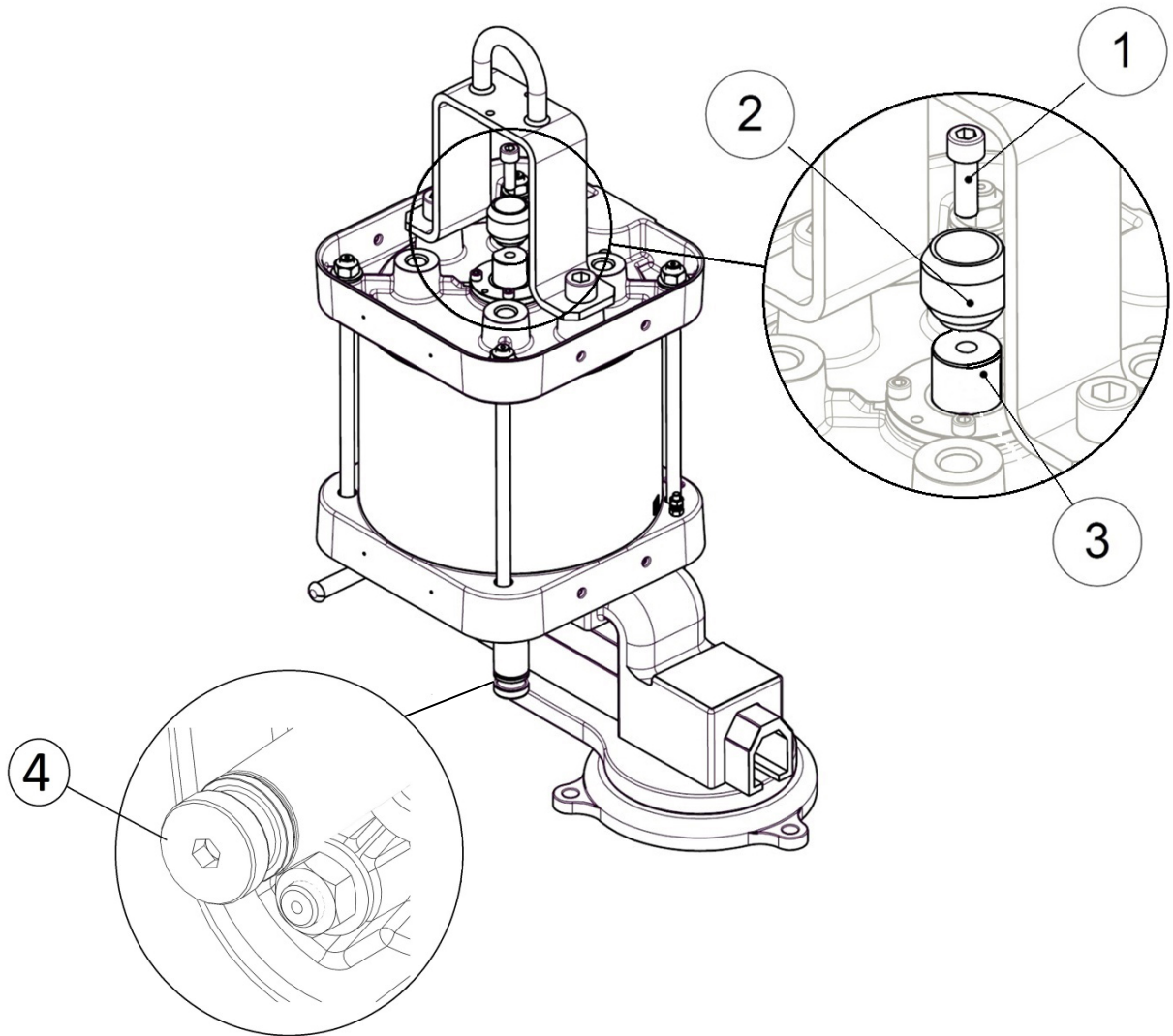

- ✓ Tighten the cam (2) with the CHC M10 screw (1), with a BTR key of 8 mm, and counterblock on the flat part of the rod with a BTR wrench of 8 mm.

Tools needed



8 x2



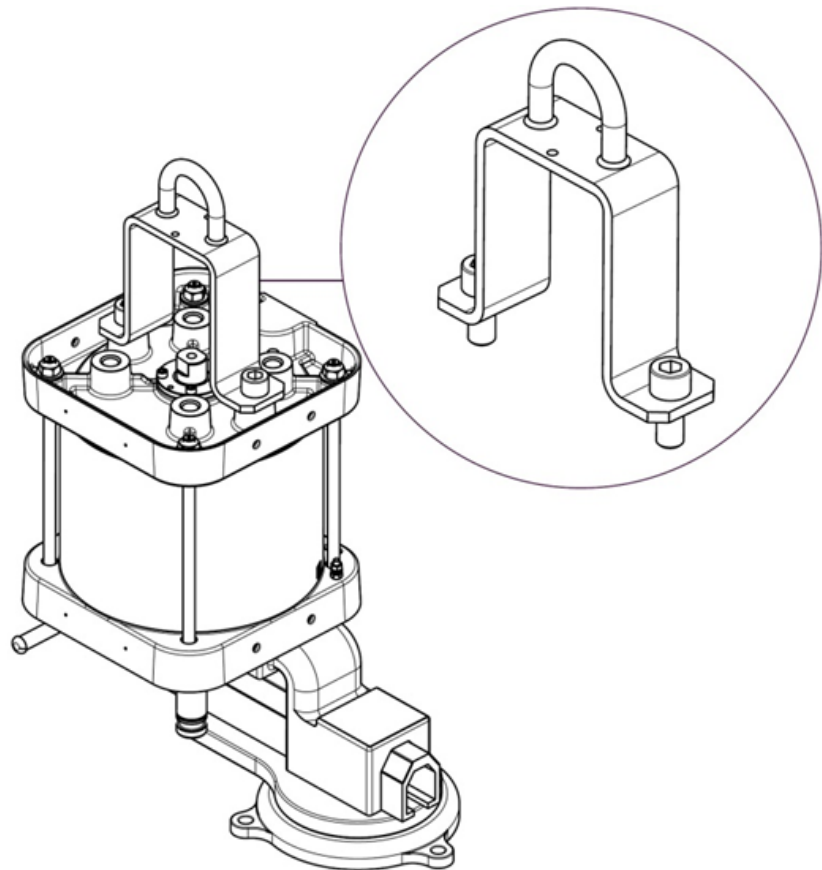

- ✓ In the case (not recommended) where the bracket has been removed, reinstall the bracket with the 2 CHC M18 screws, using a 14 mm BTR torque wrench with a torque of 260 N.m..

Tools needed



BTR14

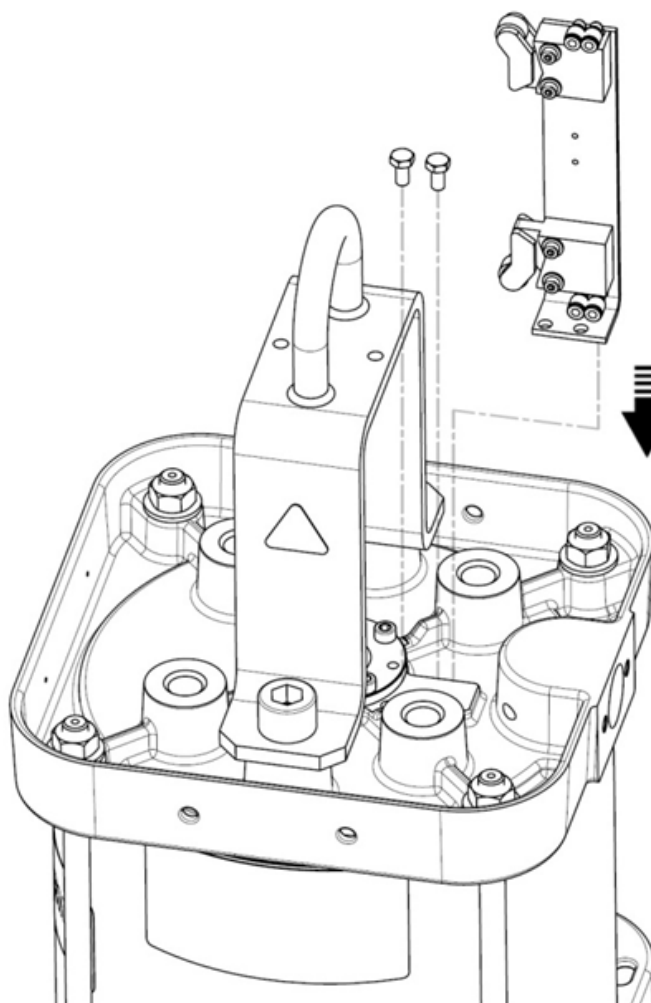

- ✓ In the case where the bracket has been dismantled, reinstall it on the motor by fixing the two screws located at its base using a spanner or a pipe wrench of 10 mm.

Tools needed

10



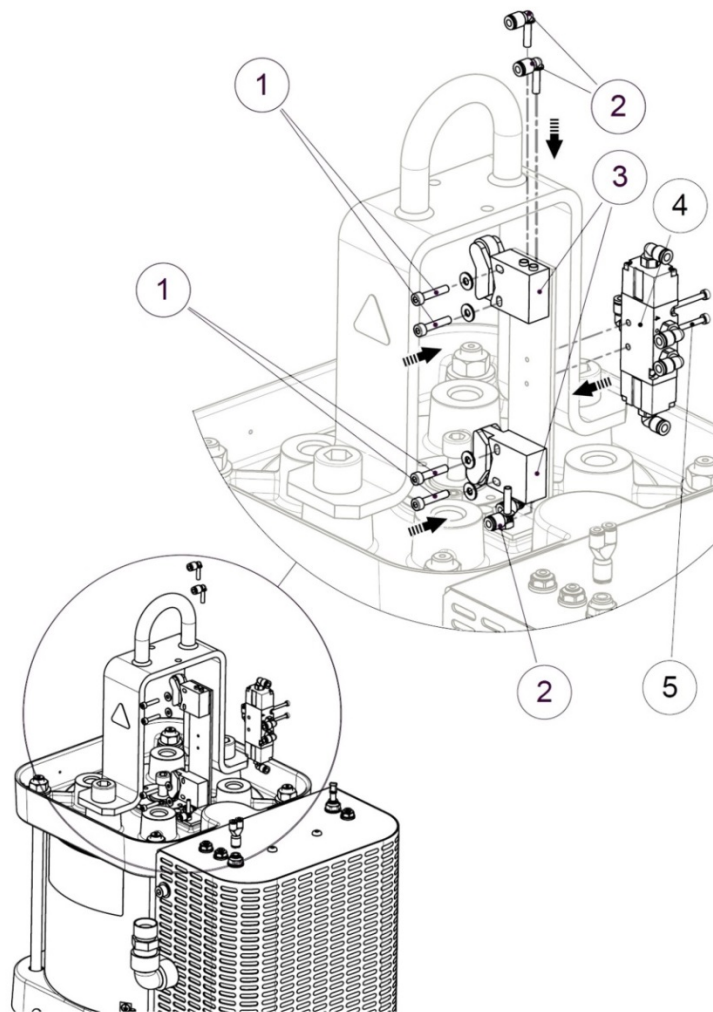

- ✓ Fix the two switch sensors (3) on the bracket by placing the washers and tightening the 4 screws (1) and the connections (2) with a BTR key of 3 mm.

Tools needed

3 

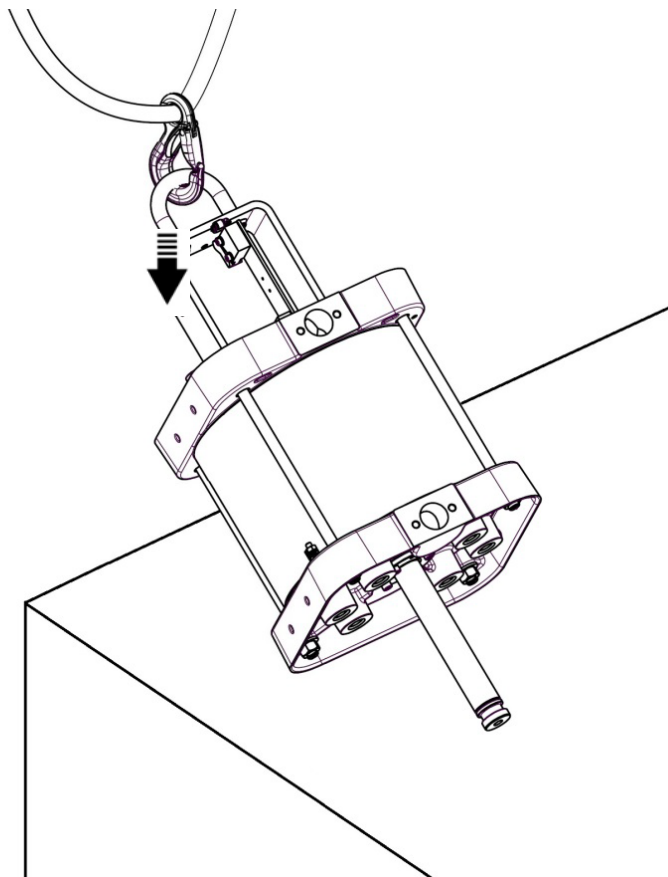

- ✓ Remove the motor unit on a horizontal plane (established type), using a lifting device hooked to the caliper.

Tools needed



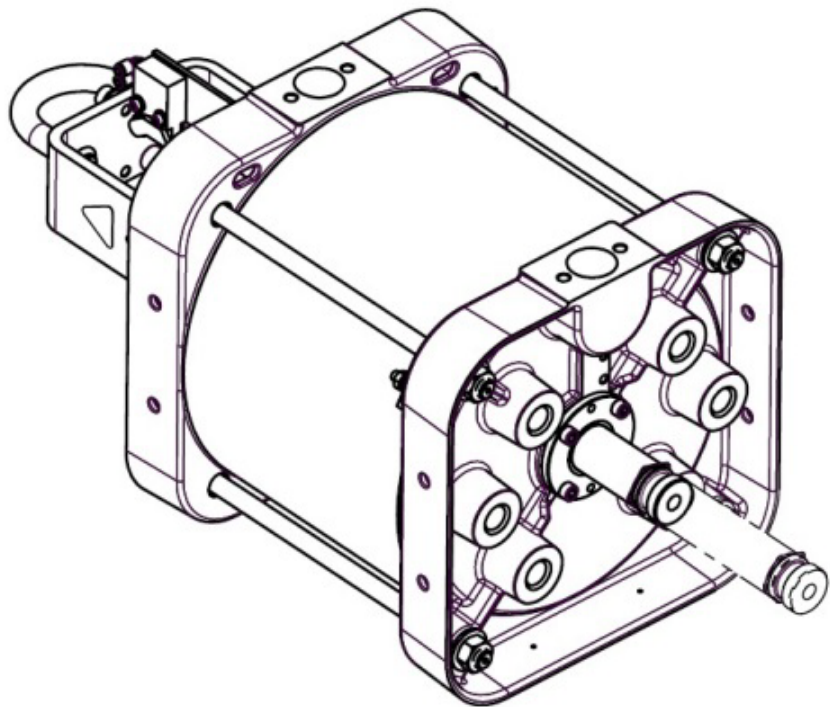

-
- ✓ Manually re-enter the motor shaft.
-

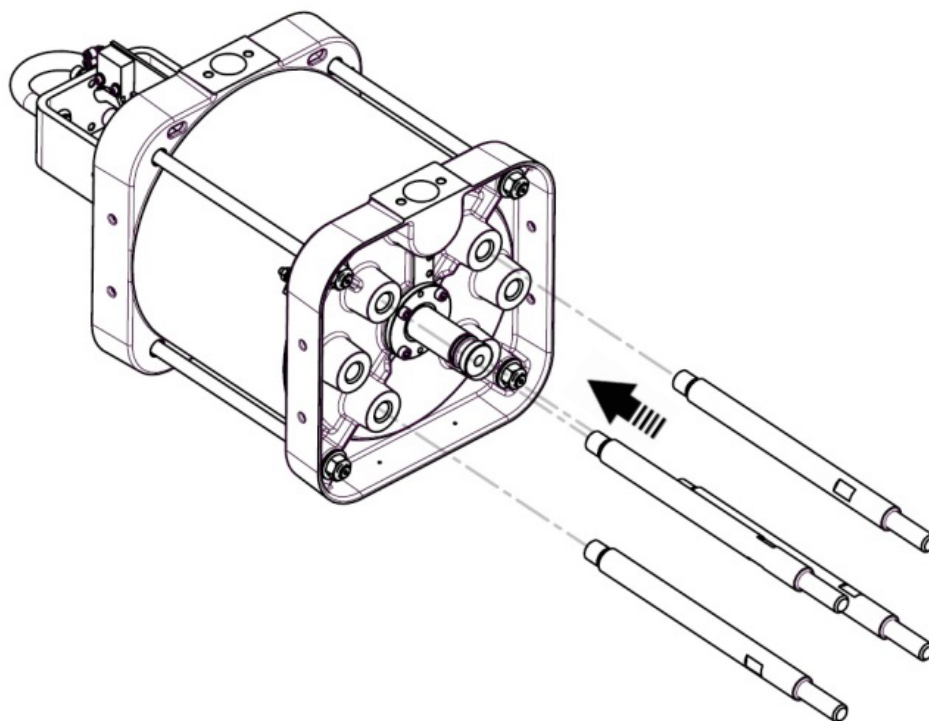

- ✓ Install the tie rods using a 19 mm torque wrench with a tightening torque of 100 N.m.



Pay attention to the tightening torque.

Tools needed

19



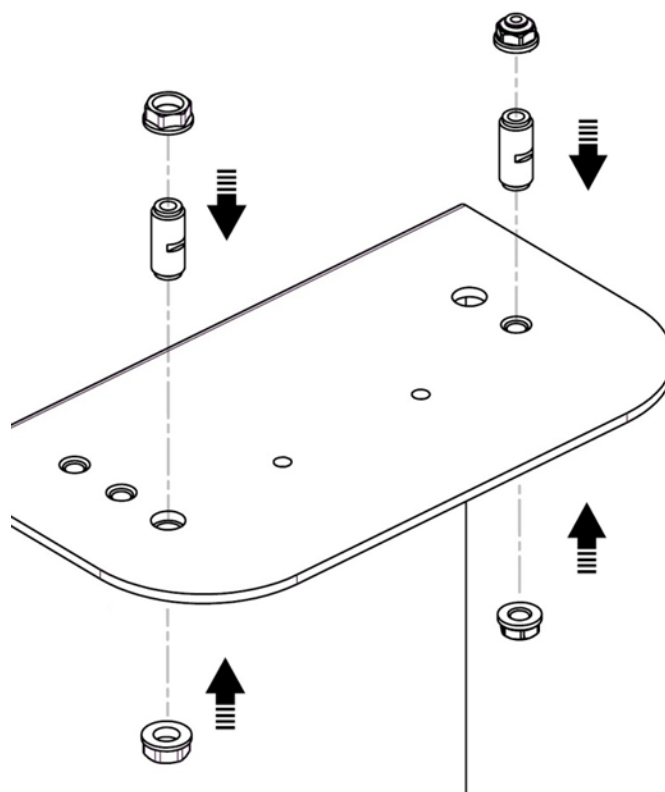

- ✓ If the bulkheads are not mounted on the plastic sheet:
 - Screw all the partition passes and onto the plastic sheet.

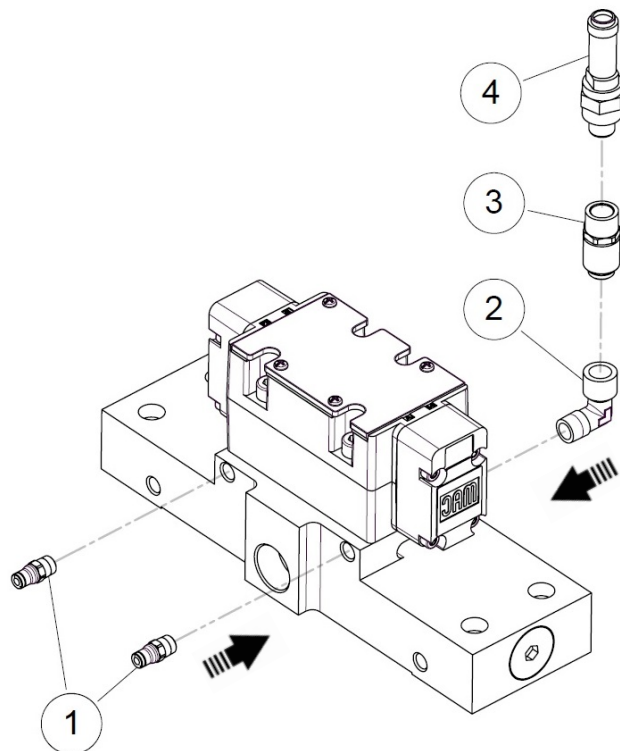

- ✓ If the base with the connections is completely disassembled:
 - Mount the 2 pipe connectors 2.7 / 4 on the base with a 10 mm spanner.
- ✓ Fit the 90 ° elbow on the base with a flat wrench of 13, and orient it according to the image below (image).
- ✓ Fit the on the 90 ° elbow with a 17 mm spanner.
- ✓ Fit the safety valve with a spanner of 20 mm.



Attention : the safety valve is a safety element - handle with care.

Tools needed

10

13

17

20



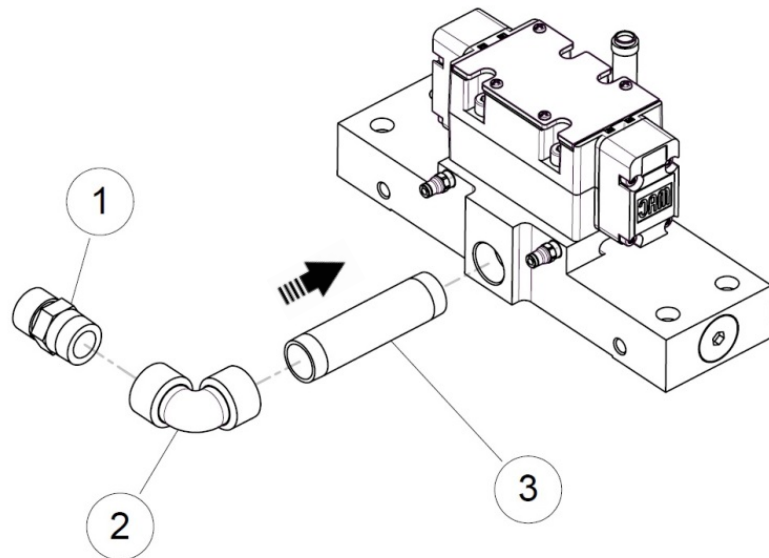

- ✓ Glue (with sealing tube glue) and screw the power supply with the elbow fitting with a 27 mm spanner.
- ✓ Glue (with glue the sealed tube) and screw the assembly on the fitting.
- ✓ Tighten with a 27 mm spanner (using connection), and put in the up position.

Tools needed



Loctite 5772

27



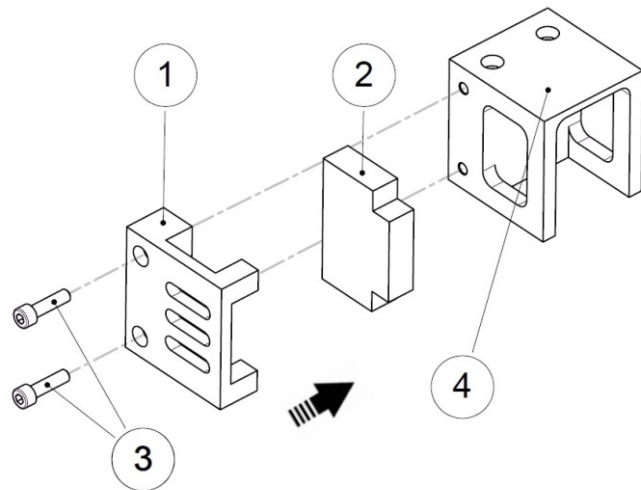

- ✓ Place in the foam (1) support rigid foam (2).
- ✓ Screw the 2 screws CHC M8 the previous subassembly on the exhaust support, with a 6 mm BTR key (x2).
- ✓ Repeat the previous two steps on the other side of the exhaust bracket (4).
- ✓ Follow the same procedure for the second exhaust support.

Tools needed**6**

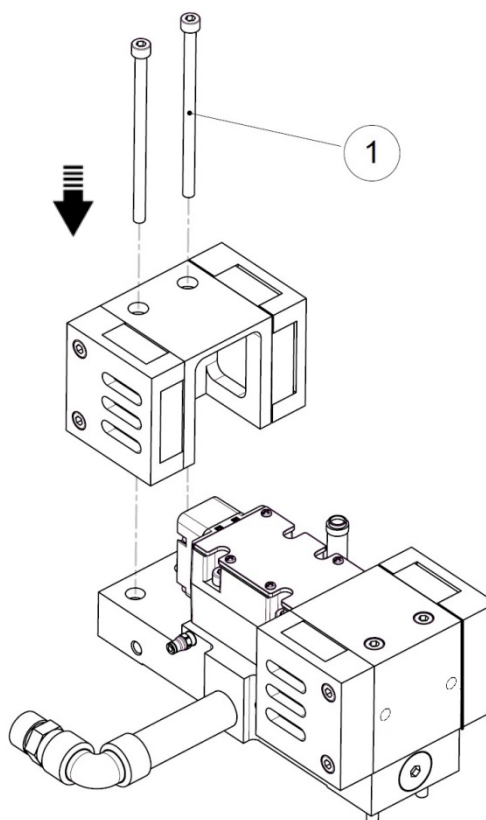

- ✓ Place the 2 previous sub-assemblies on the equipped base, with the 4 screws CHC M8.

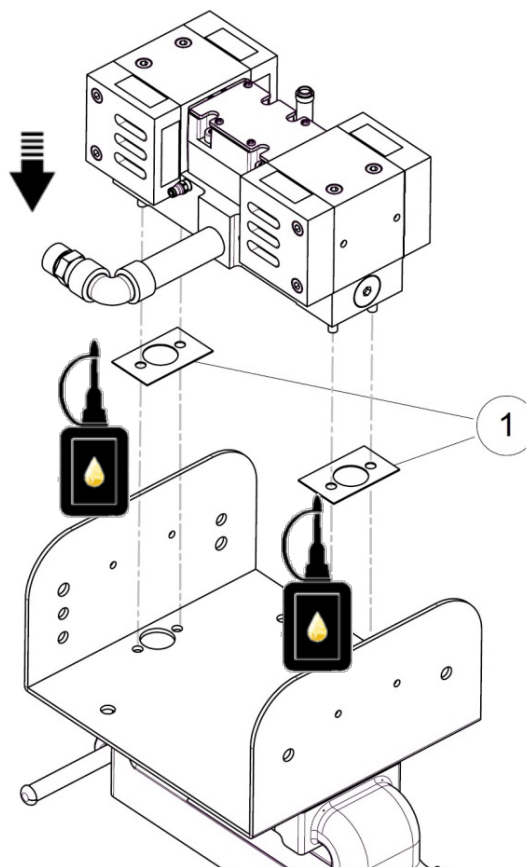

- ✓ Stabilize the plastic plate of the housing on the vise, to facilitate the work of fixing the joints.
- ✓ Place the two base seals (between the plastic plate and the base).



Attention

Be sure to grease the joints sufficiently to promote adhesion to the substrate.

Tools needed



**Kluber petamo
HY 133N**

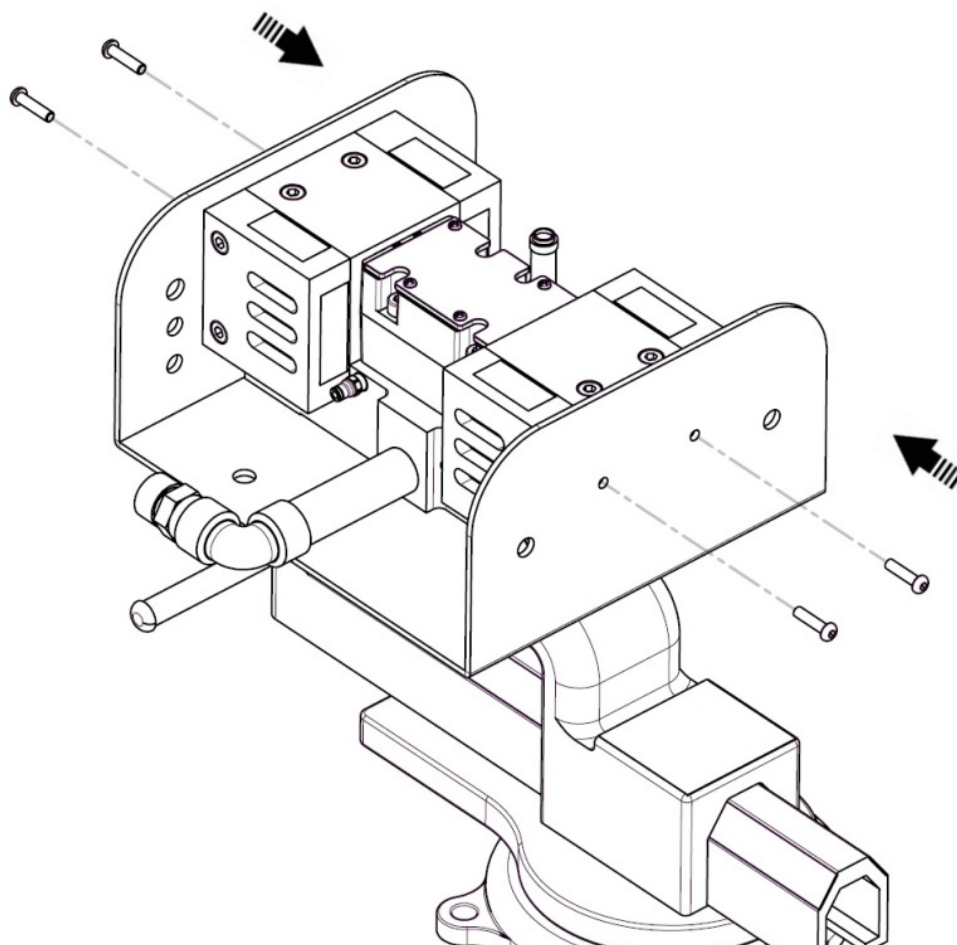

- ✓ Using a 4 mm BTR wrench, attach the distributor assembly to the plastic sheet with the 4 screws.

Tools needed

4 

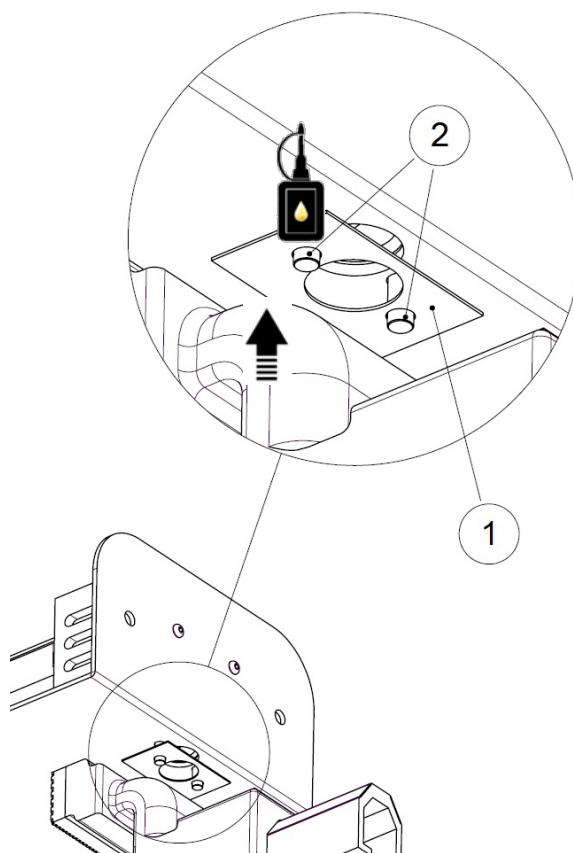

- ✓ Place the two other base seals (1), on the outside of the plastic sheet of the housing, by passing them in the screws (2).
- ✓ Grease the seals.

Tools needed



**Kluber petamo
HY 133N**

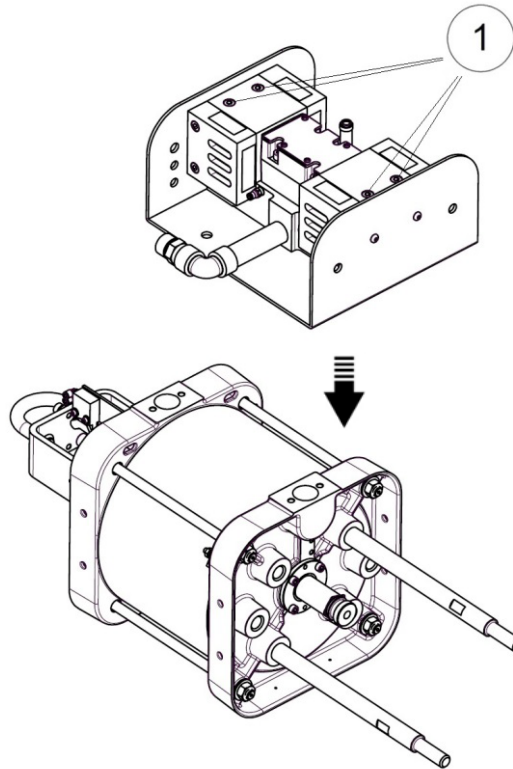

- ✓ Move the assembly to the motor flanges, and screw the 4 screws CHC M8 with a 6 mm BTR key.

Note: Check the tightness so that there is no daylight at the seals.

Tools needed



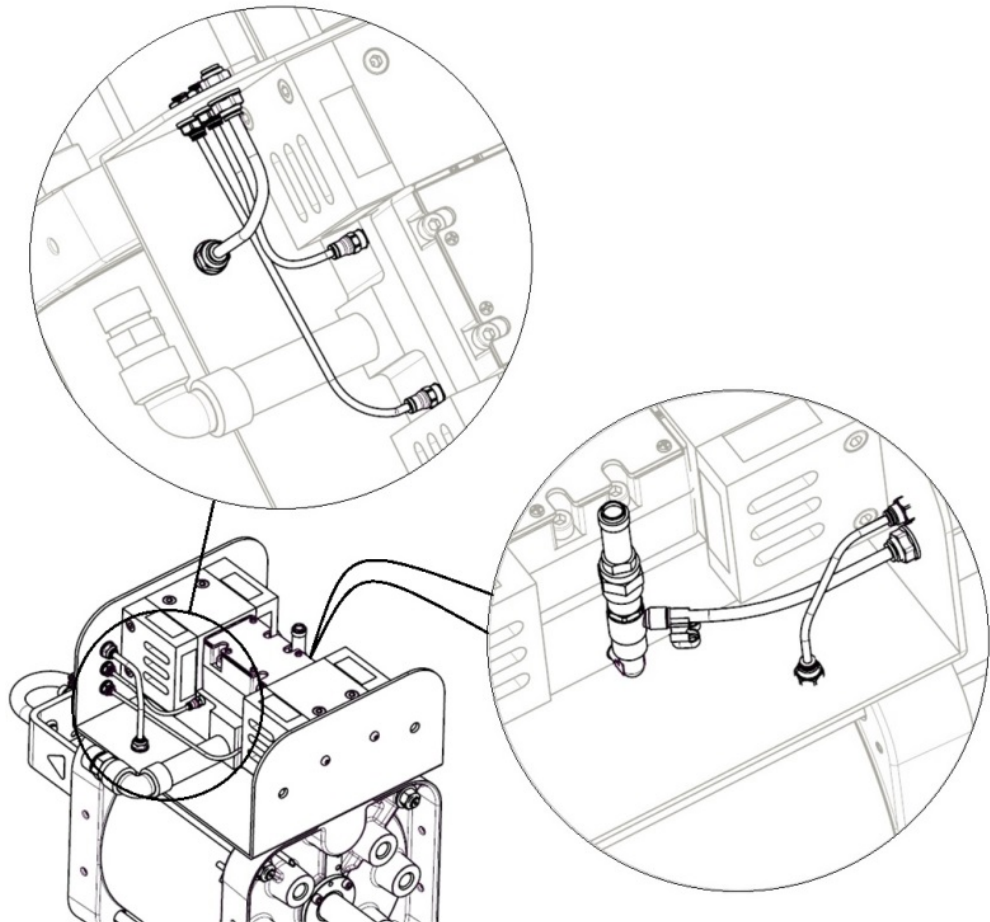

- ✓ Make the pneumatic wiring of the distributor part.

Wall bracket option

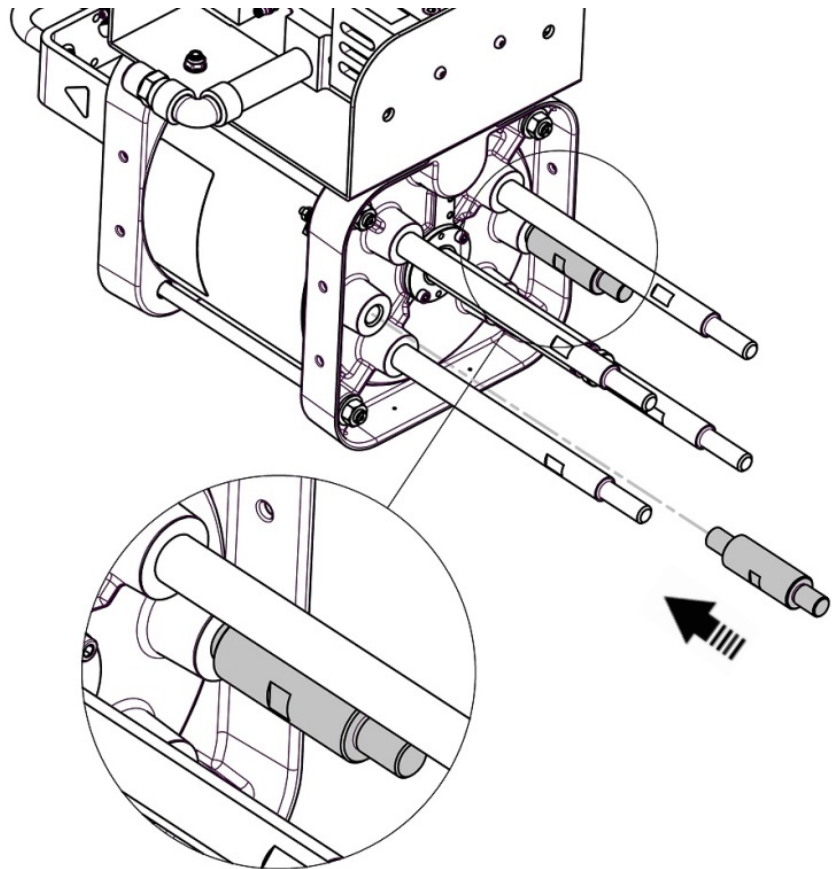

- ✓ Screw both daggers with a 27 mm torque wrench with a tightening torque of 260 Nm on the lower flange.

Tools needed

27



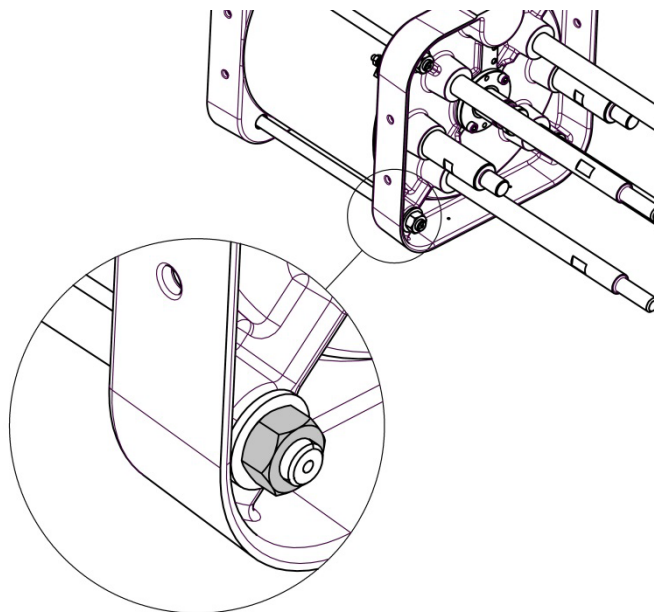

- ✓ Using a 19 mm torque wrench, tighten the 4 nuts of the tie rods with a tightening torque of 100 N.m

Tools needed

19



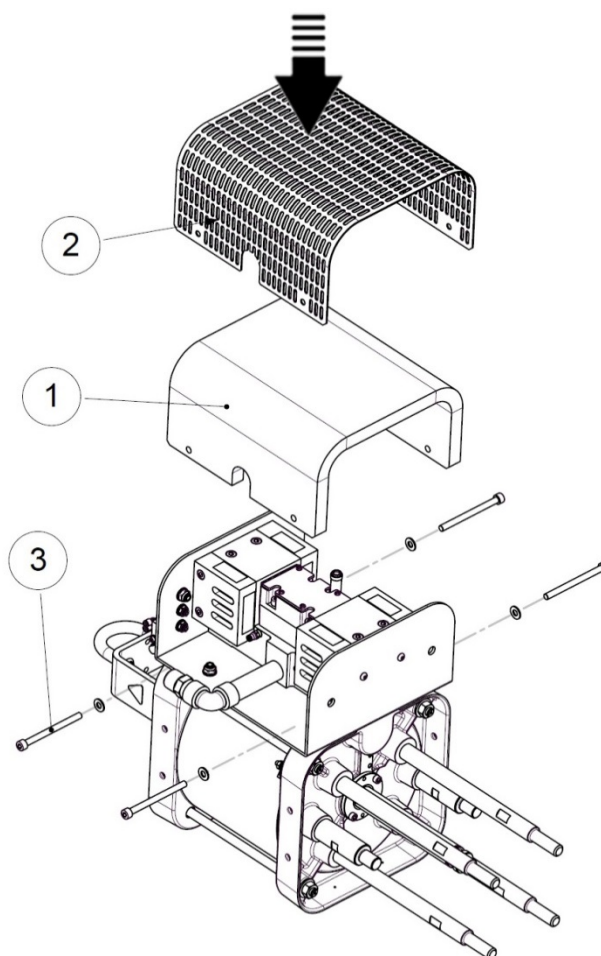

- ✓ Place the foam and the grid, by putting the 4 washers and the 4 screws CHC M8 with a key BTR of 6 mm.



Attention

Manually maintain pressure on the plate (1) to tighten the 4 screws.

Tools needed

6



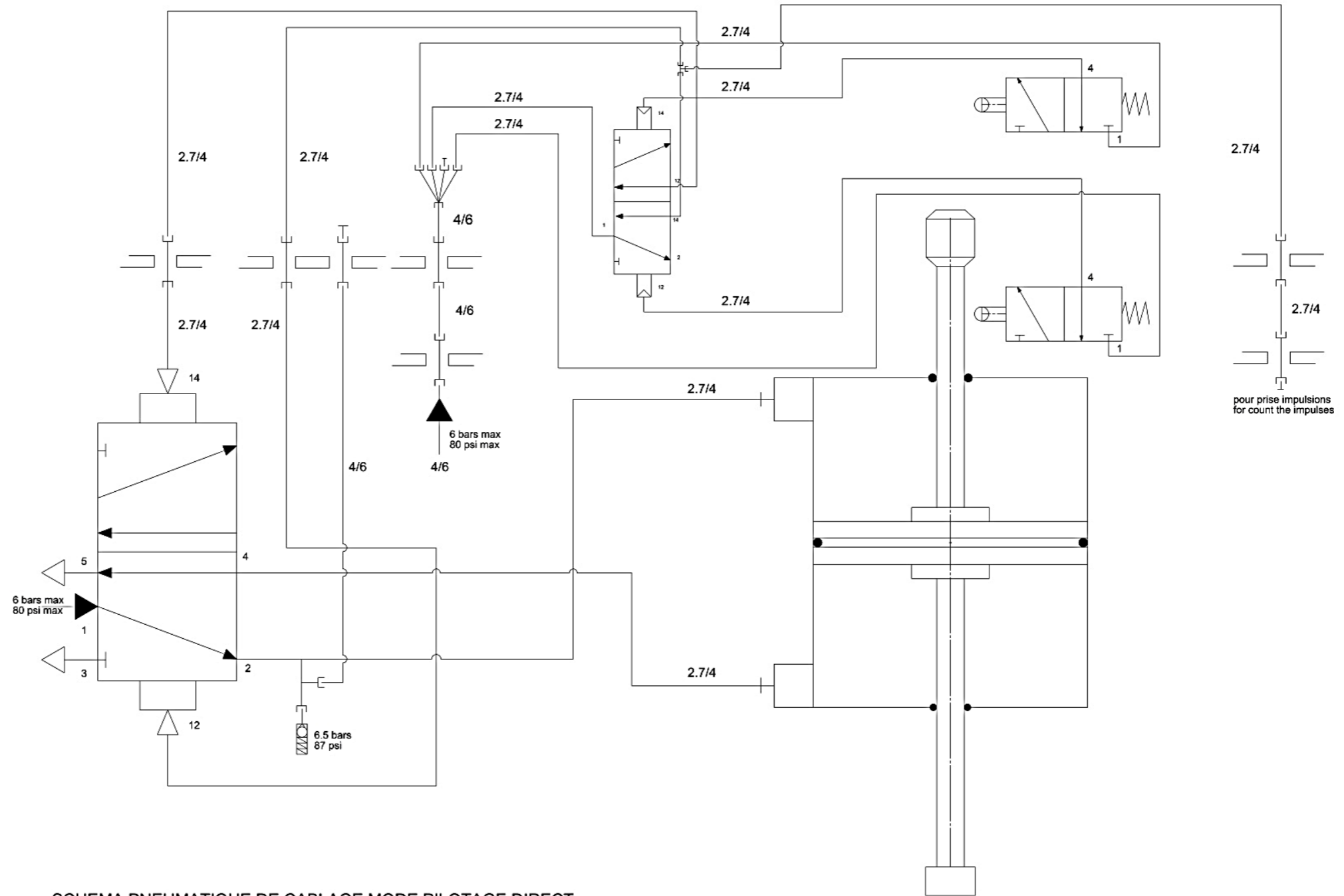

SCHEMA PNEUMATIQUE DE CABLAGE MODE PILOTAGE DIRECT
 PNEUMATIC WIRING DIAGRAM FOR DIRECT PILOTING MODE

- ✓ Make the pneumatic wiring of the upper part.

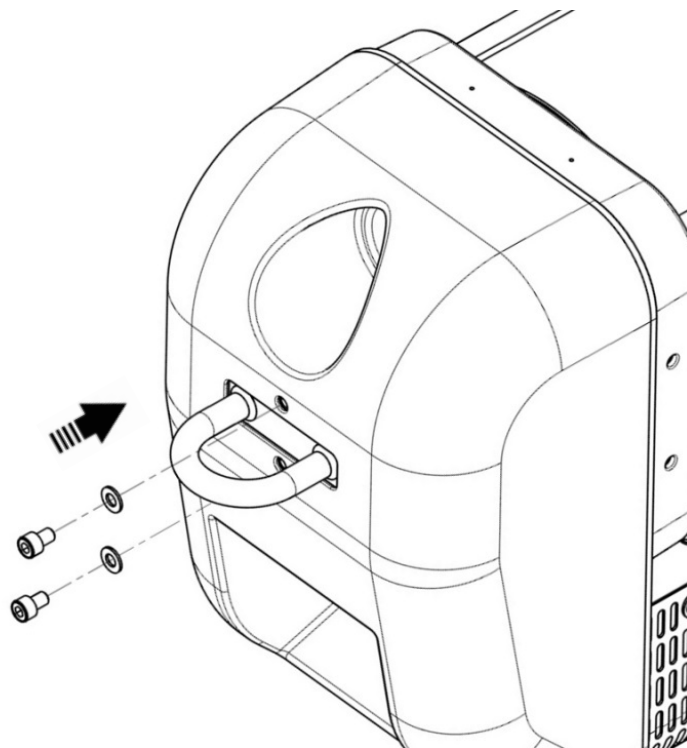

- ✓ Place the cover and washers by screwing in the CHC M8 screws with a 6 mm BTR wrench.

Tools needed

6



Wall bracket option

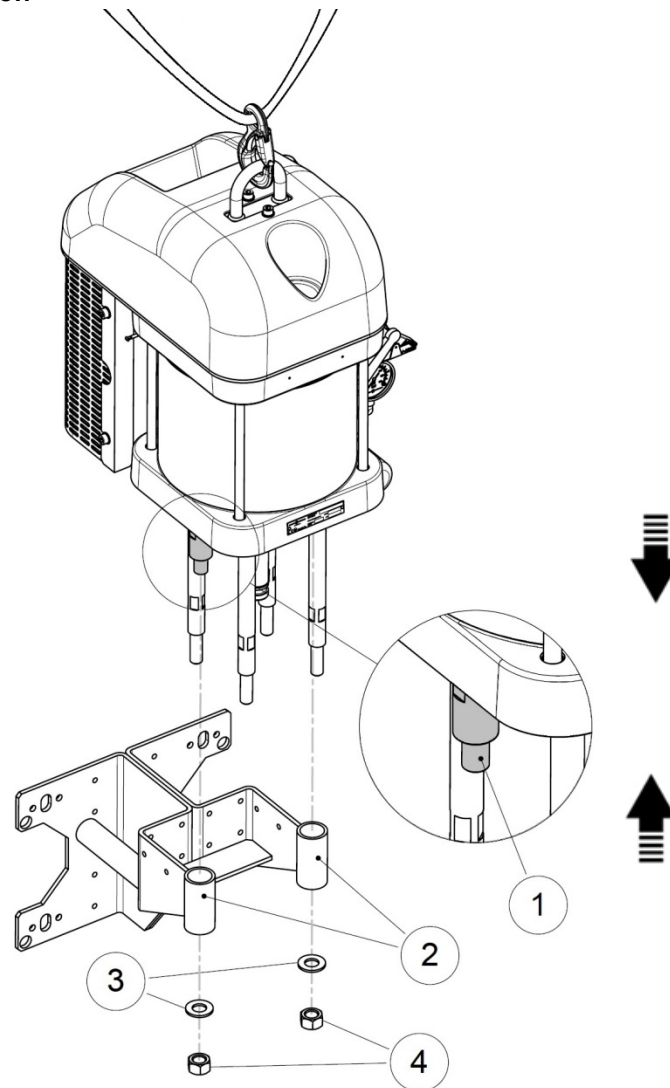

✓ With lifting means:

- Place the assembly on the support (option) and screw the 2 nuts + washers, 27 mm torque wrench with a tightening torque of 100 N.m.

Tools needed



27



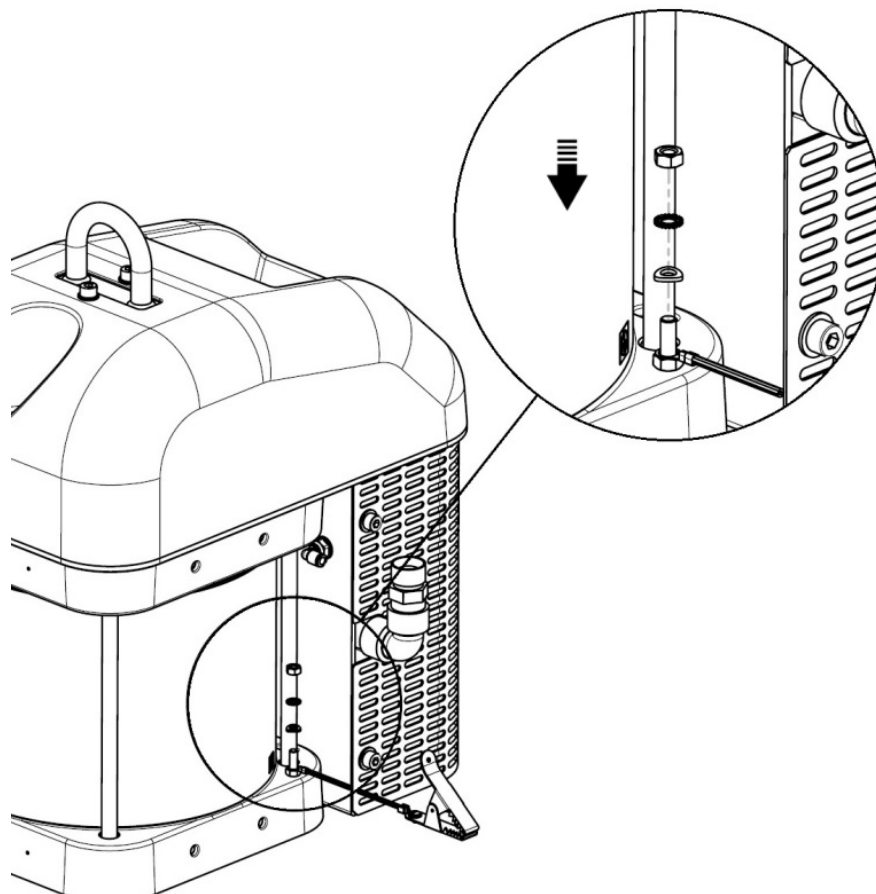

- ✓ Reinstall the grounding cable with a wrench of 10 mm.

Tools needed

10



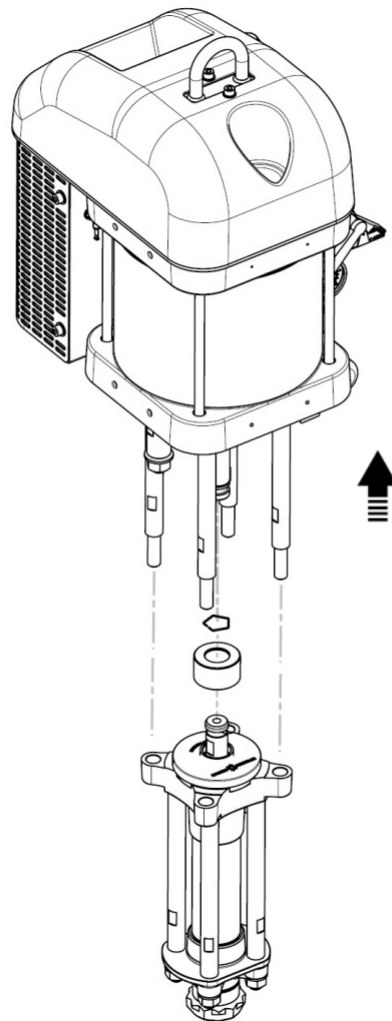

- ✓ Place the axle brake and the locking ring along the motor shaft.
- ✓ Make the coupling of the motor to the fluid section.

Note: It is important to perform this operation vertically.



Attention: Support the fluid section well (Fluid section weight: 11 kg / 24.25 lbs).

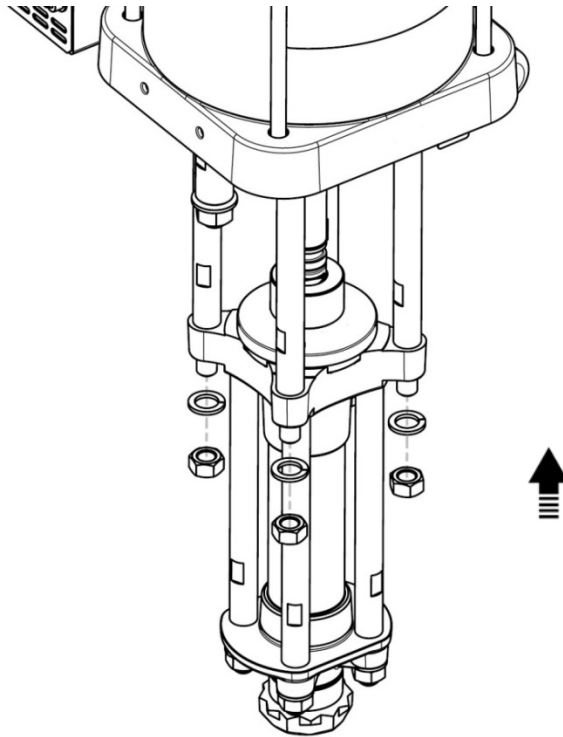

- ✓ Put the fluid section back in place, by manually screwing the 4 M16 nuts in contact.
- ✓ Coupling to the fluid section.
- ✓ Connecting the Air supply.
- ✓ Run the pump slowly at no load for 3 cycles to align the pump seals vertically.
- ✓ Tighten the four nuts in star, to the torque of 100 N.m.

Outillage nécessaire

24



15 Pneumatic Wiring

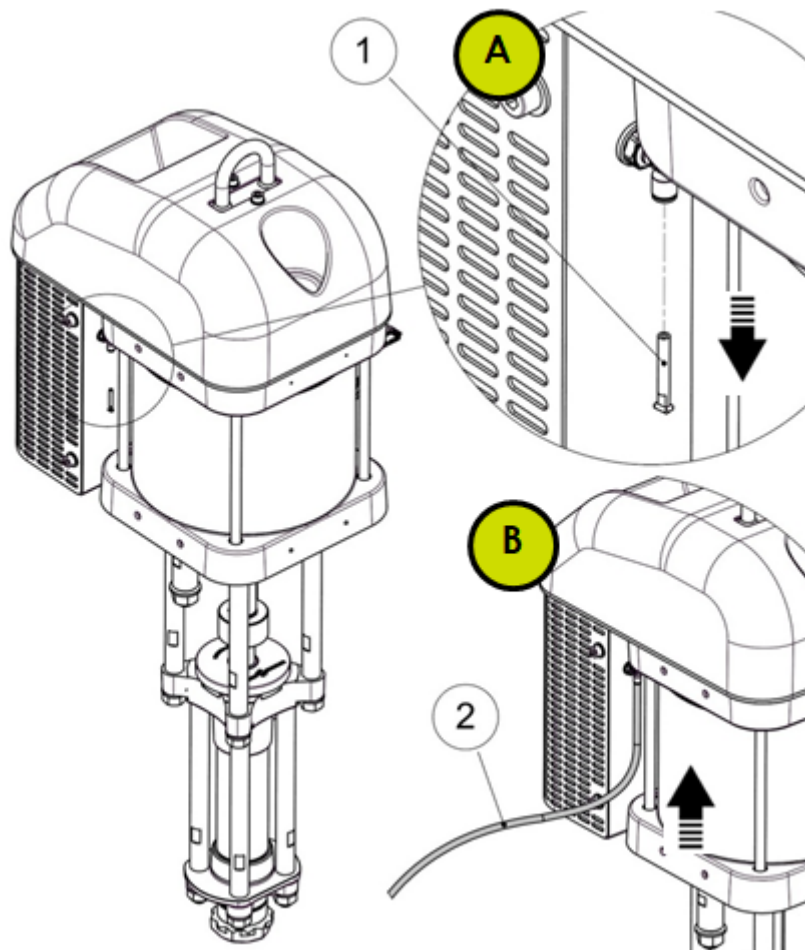

Count cycles pneumatic

- ✓ (A) Remove the plug (1) from the fitting on the left side of the pump (in front view).
- ✓ (B) Connect a 4/6 hose (2) to the coupling on one end and to the metering equipment on the other end.

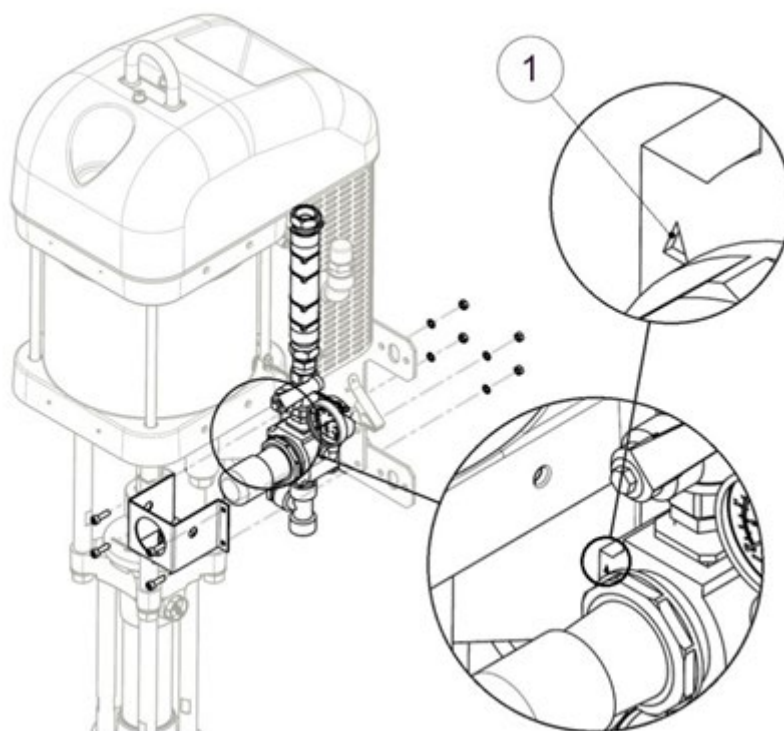

Fit the regulator

- ✓ Install the regulator of the air equipment, respecting the direction of assembly: the direction of air circulation is given by the arrow (1).

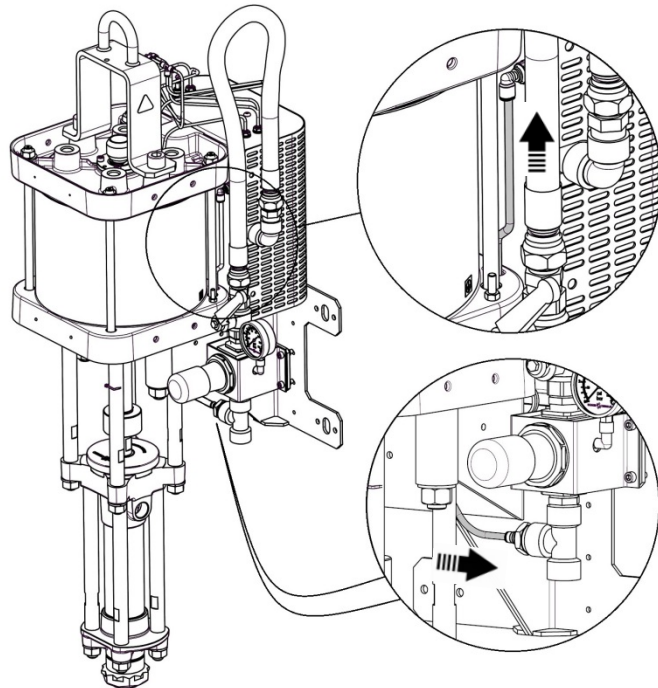

Direct air control

- ✓ Install the side pipe along the motor cylinder, passing through the bulkhead from the crankcase on one side, and the lower flange of the motor on the other hand.
- ✓ Connect the direct pilot hose to the fitting below the regulator.

Indirect air control

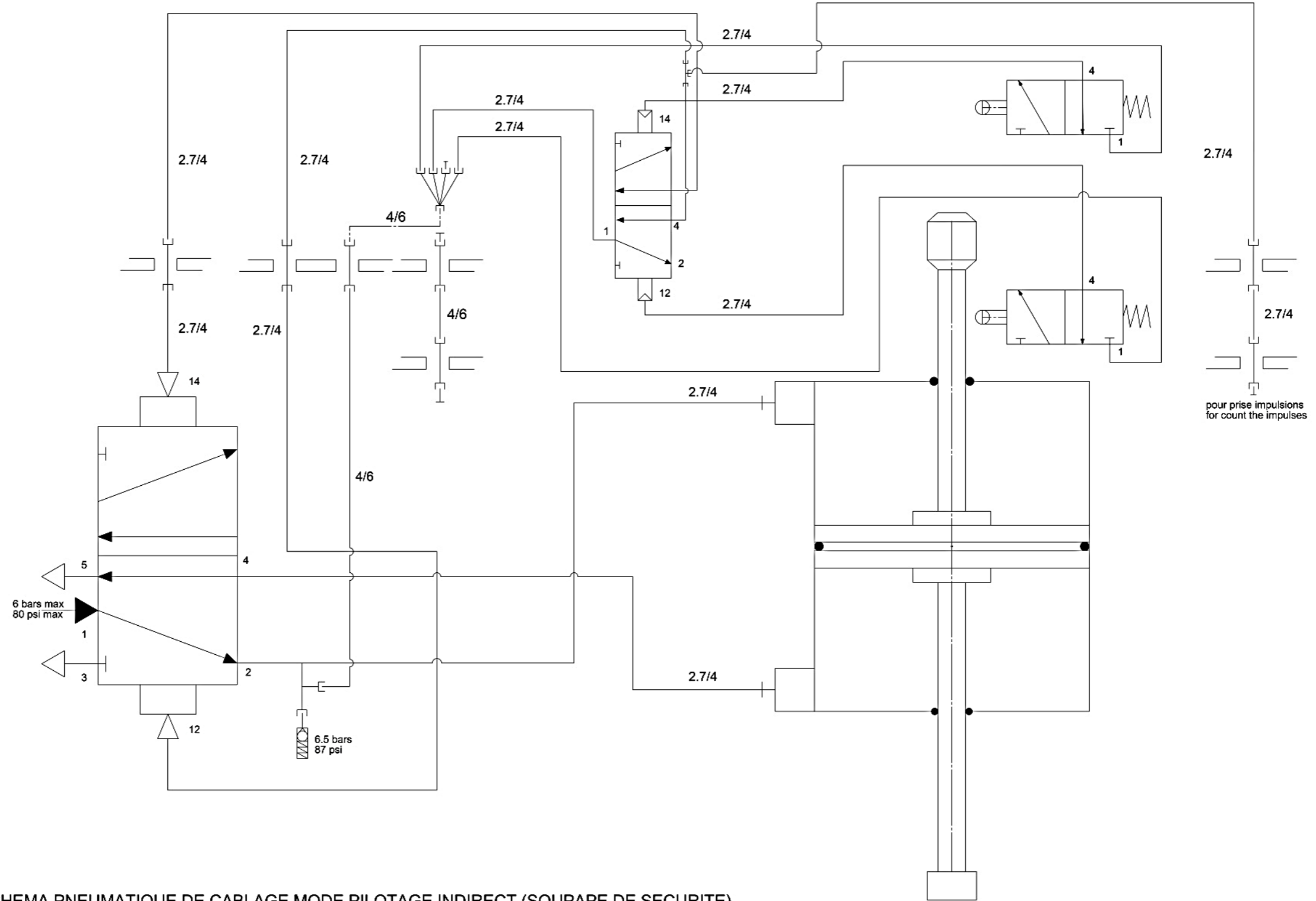

SCHEMA PNEUMATIQUE DE CABLAGE MODE PILOTAGE INDIRECT (SOUPAPE DE SECURITE)
 PNEUMATIC WIRING DIAGRAM FOR INDIRECT PILOTING MODE (SAFETY VALVE)

16 Filter

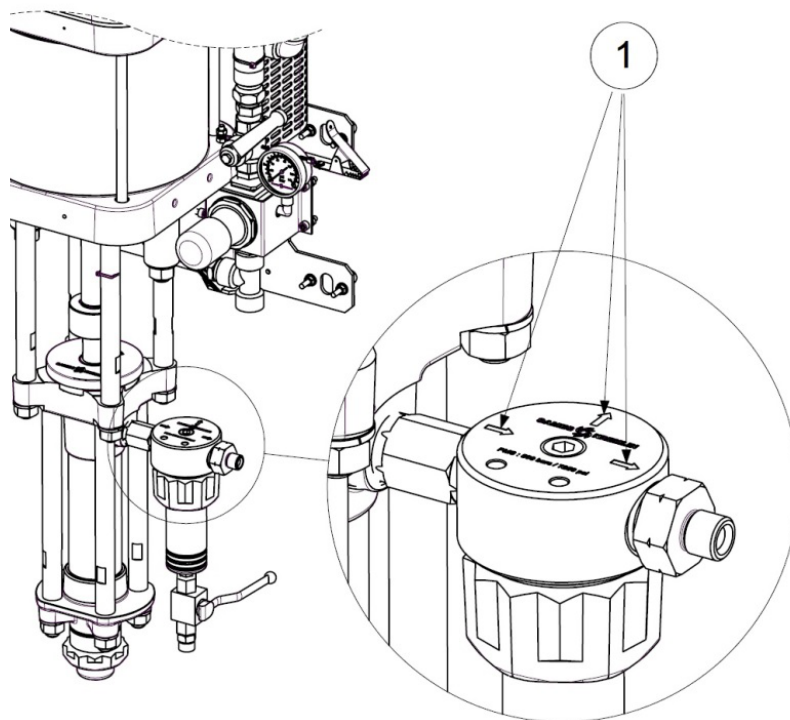

Install filter

- ✓ Observe the direction of the arrows (1) for circulation of the product.

Note: The filter can be mounted in the up or down position. In this manual it is shown in the lower position.

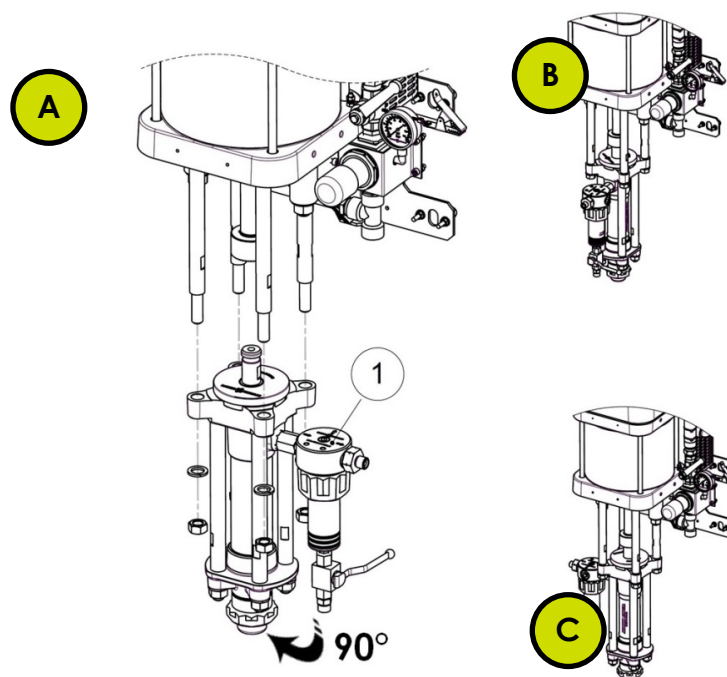

Orientation of the product output

- ✓ (A) By default, the filter (1) is installed to the right of the pump (front view).
- ✓ (B) and (C) It is possible to change the position of the product output by first removing the 4 nuts and washers to disconnect the fluid section part (on which the filter is mounted) of the motor

Note: (B) possible if hopper is missing.



Attention: Support the fluid section well (Fluid section weight: 11 kg / 24.25 lbs).

Tools needed

24



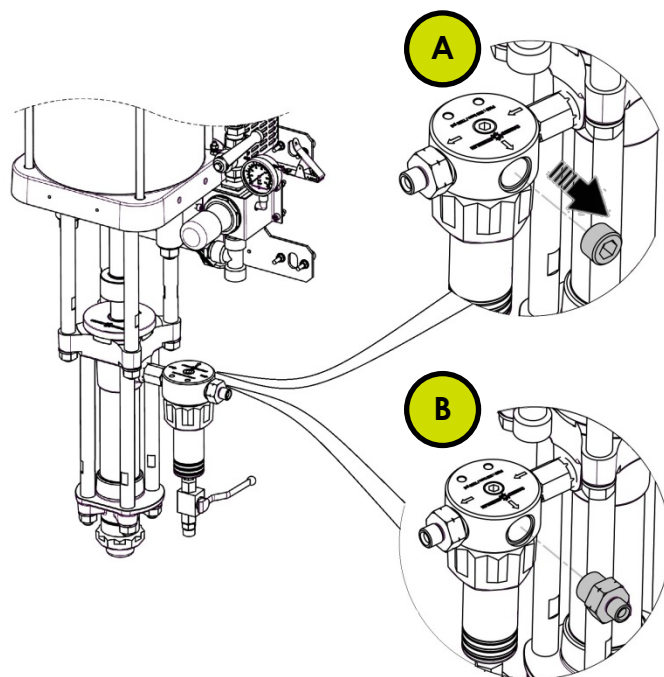

Connecting a second gun

- ✓ (A) To install a second spray gun on the filter, first remove the cap, with a 14 mm BTR wrench, located on the filter base.
- ✓ (B) Glue and screw the connection with a 32 mm open-end wrench to the empty location.

Tools needed

32



14



Loctite 5772

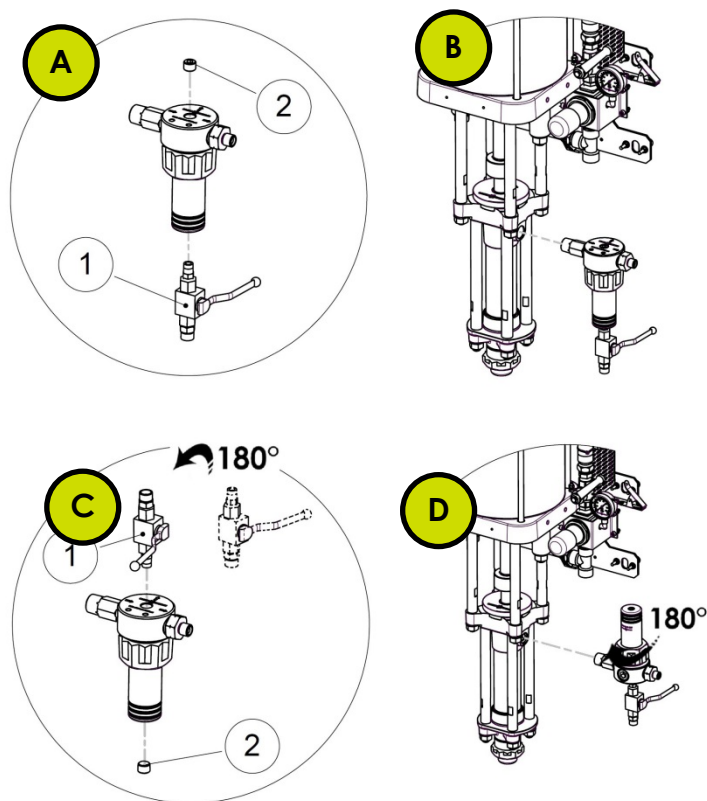

Reversing the direction of the tank

- ✓ (A) Remove the valve (1) from the filter with a 21 mm spanner and the cap (2) using a BTR key of 8.
- ✓ (B) Using a flat wrench of 27, rotate the filter by 180°.
- ✓ (C) Install the valve (1) at the other end of the filter by turning it 180°; replace the cap (2) at the top of the filter with waterproof tube glue.
- ✓ (D) Install the valve (1) at the other end of the filter by turning it 180°; replace the cap (2) at the top of the filter with waterproof tube glue.

Note: This position increases the risk of paint stagnation in the base.

Tools needed

27



21



8



Loctite 5772

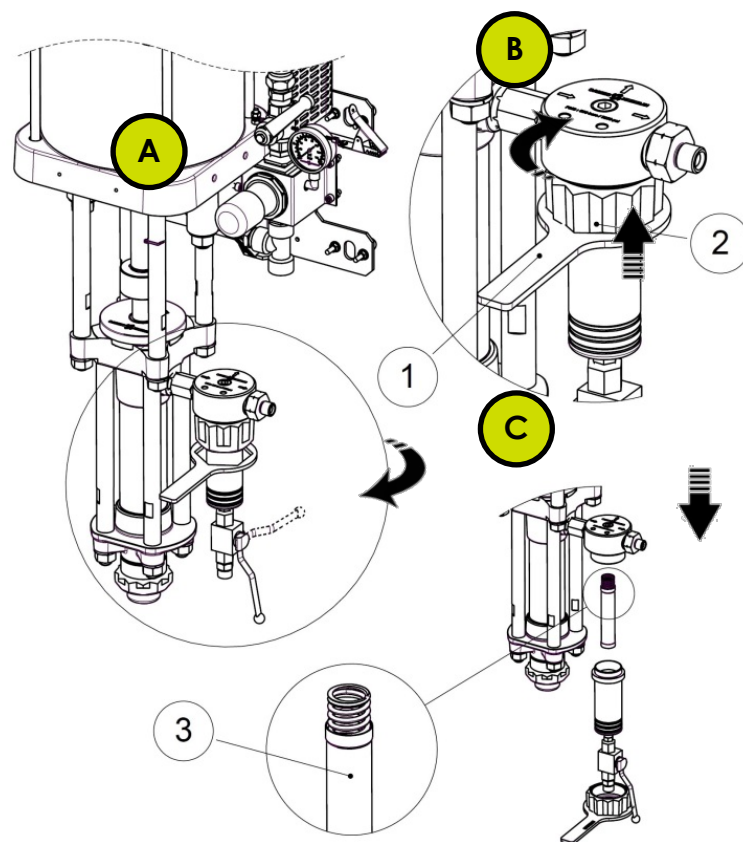

- ✓ To disassemble the filter.
- ✓ Place the integral key (1) against the corresponding projections on the filter ring (2).
- ✓ Unscrew the ring (2) and remove the filter to access the filter elements (3) to change them.

Tools needed



17 Operations Dismantling / Reassembling the C225 Fluid section

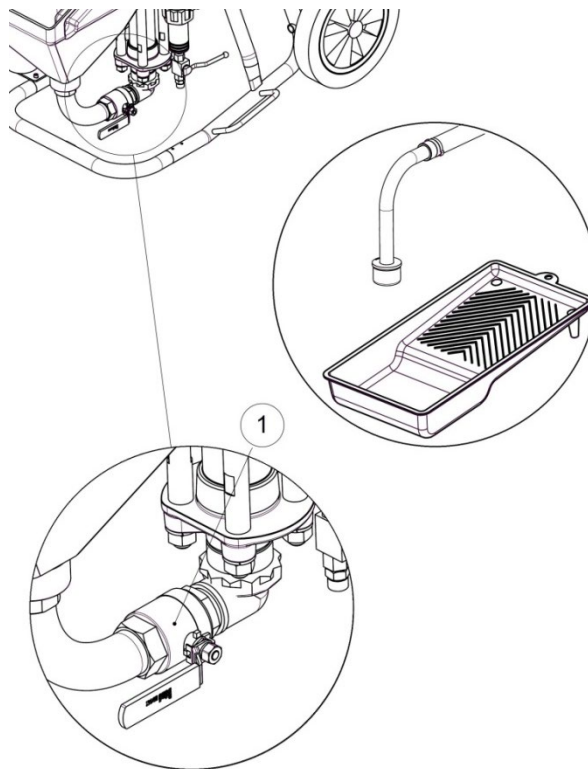

- ✓ Drain the pump, cane or hopper.

Note: It is possible to stop feeding the hopper by the valve.

Note: Do not close the valve (1) while the pump is running.

- ✓ Solvent the recirculating pump with solvent, using the filter valve and the 1.5 m hose (option), and drain the pump.

- ✓ In case of replacement of the hopper strainer:
 - Lift the hopper lid and manually pull out the strainer.
- ✓ In case of replacement of the cane strainer:
 - unscrew the strainer manually and replace it

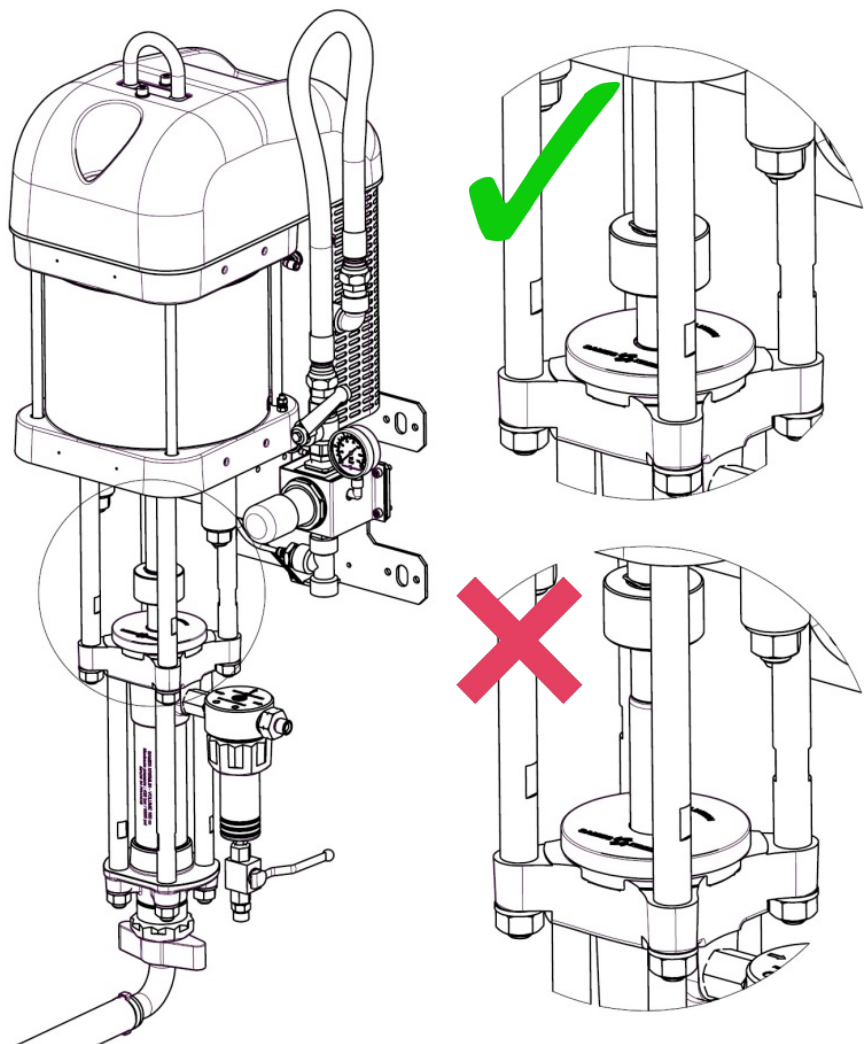

-
- ✓ Stop the pump in the low position. Fluid section rod in low position
-

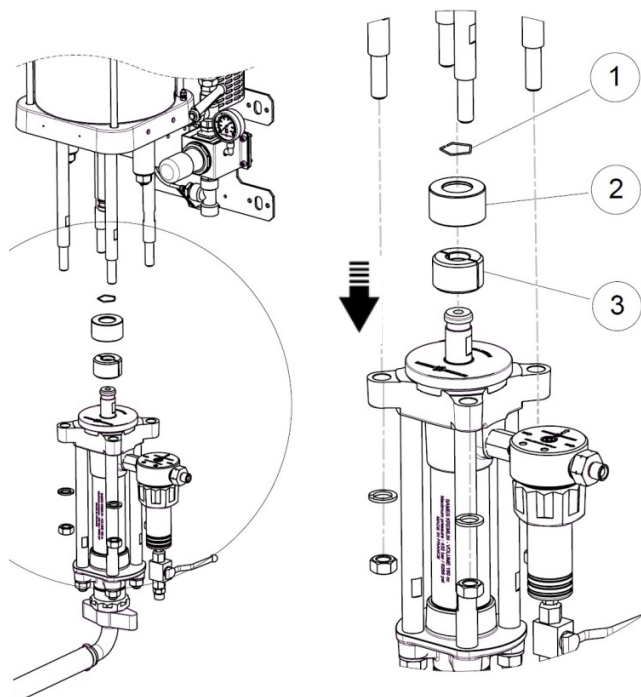

17.1 Dismassembly

Change the upper seals (8 chevrons + PTFE O-ring):

- ✓ Release the axle brake (1) from the groove above the locking ring (2), to disengage the coupling nuts (3).
- ✓ Remove the 4 nuts with a 24 mm open-end wrench
- ✓ Disconnect the motor from the fluid section (uncoupling phase).



Attention: Support the fluid section well (Fluid section weight: 11 kg / 24.25 lbs).

Tools needed

24



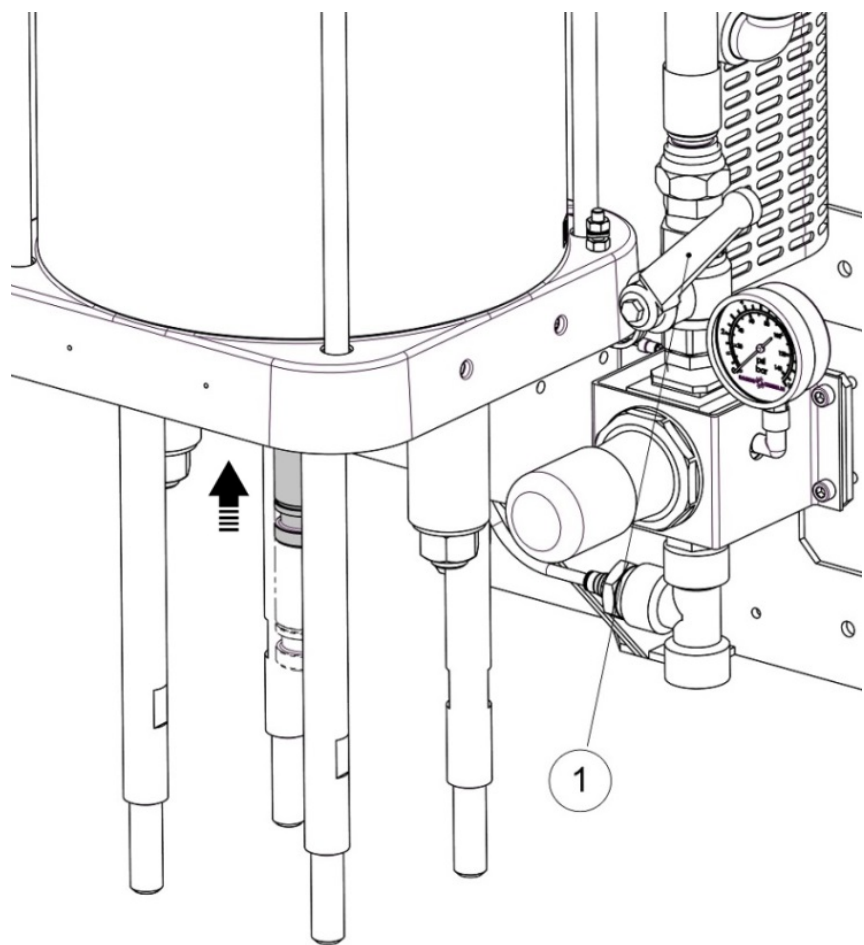

-
- ✓ With the regulator
 - Put the motor rod in the up position
 - ✓ With the valve
 - Close the valve (1).
-

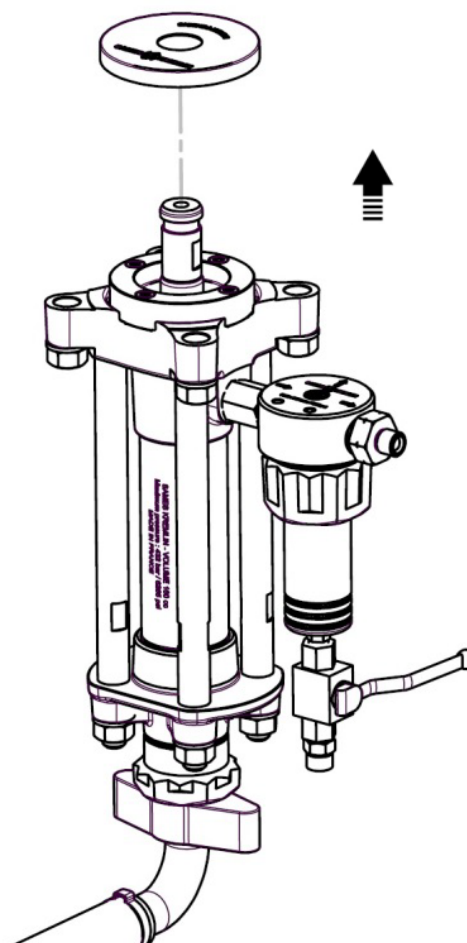

- ✓ Remove the cover.

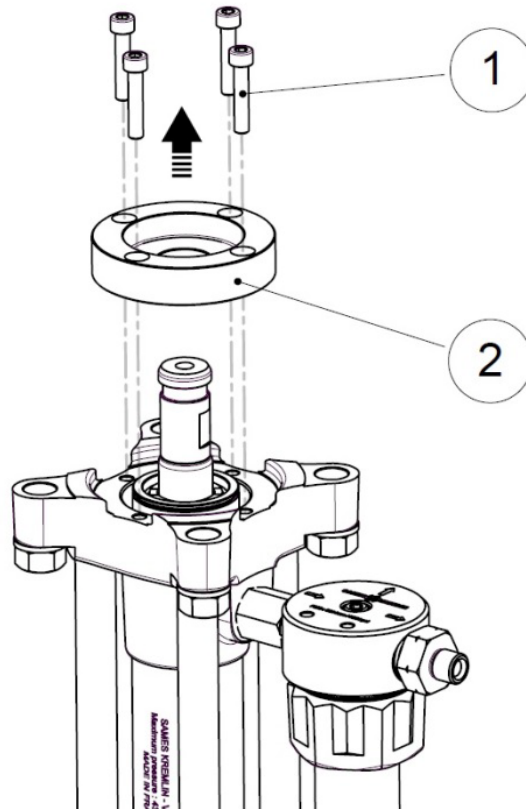

- ✓ Unscrew the 4 screws CHC (1) with a key BTR of 6 mm.
- ✓ Remove the flange (2) manually.

Tools needed



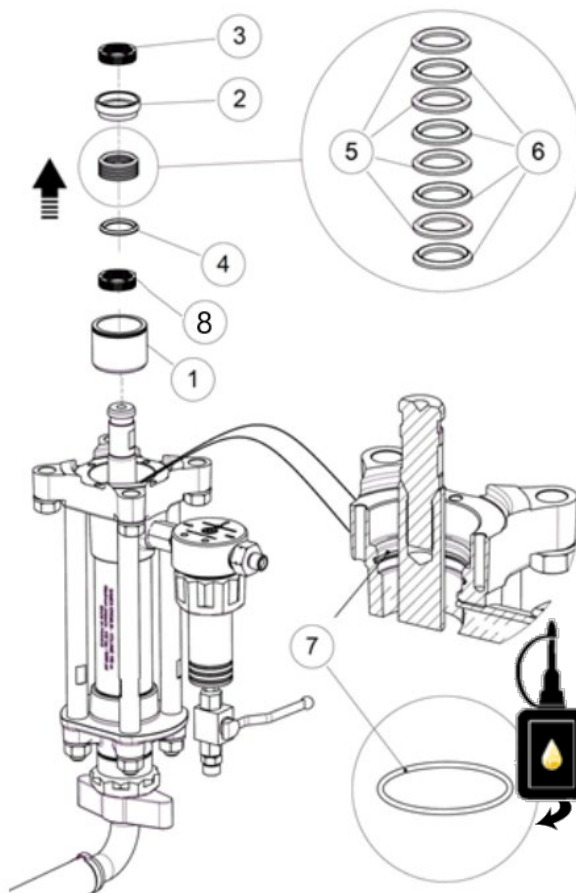

- ✓ With a flat screwdriver in the groove of the cartridge body (1), remove the cartridge (1), spring cartridge (2), spring (3) + male seal press (4) + 8 V-seals (5 and 6) + adjustment wedges (8), positioning it.
- ✓ Change the V (5) and (6) joints, taking care to respect the order of the rafters.
- ✓ Remove the seal (7) using a flat screwdriver.
- ✓ Change and grease it.

Tools needed



**Kluber petamo
HY 133N**

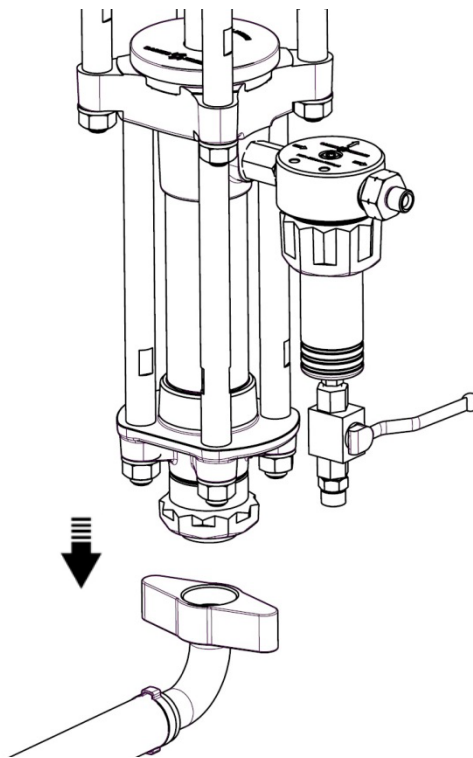

- ✓ With suction cane option:
 - Remove the suction rod with a mallet, keeping it at the elbow.
- ✓ With hopper option:
 - Unscrew the knurled nut manually by a few millimetres.
 - Unscrew the nut from the fitting with a 55 mm wrench.
 - Remove the entire bracket from the front.

Tools needed

55



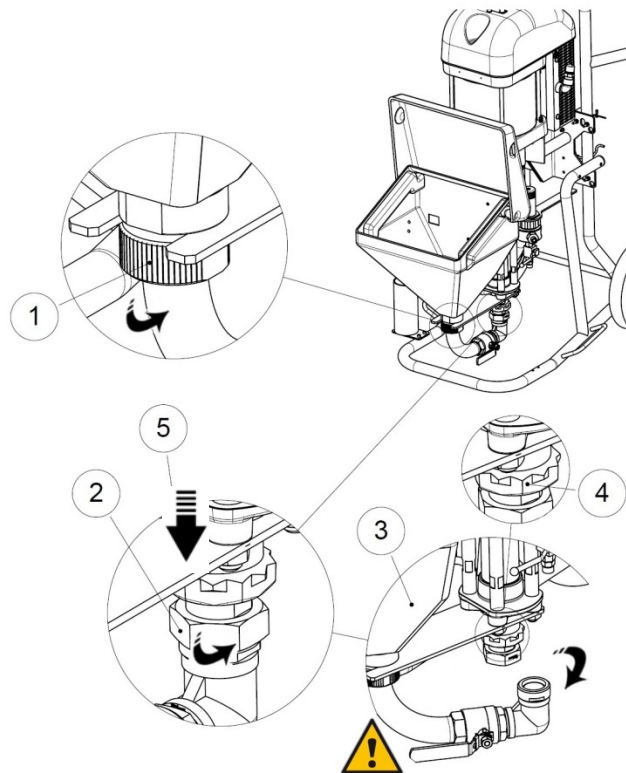

Disassembly of the pump hopper assembly to access the suction valve:

- ✓ Unscrew the knurled nut (1) manually by a few millimetres.
- ✓ Unscrew the nut from the fitting (2) with a 55 mm wrench.
- ✓ Rotate the hopper (3) to access the suction valve.
- ✓ Tighten the knurled nut (1) manually to stabilize the hopper.

Tools needed

55



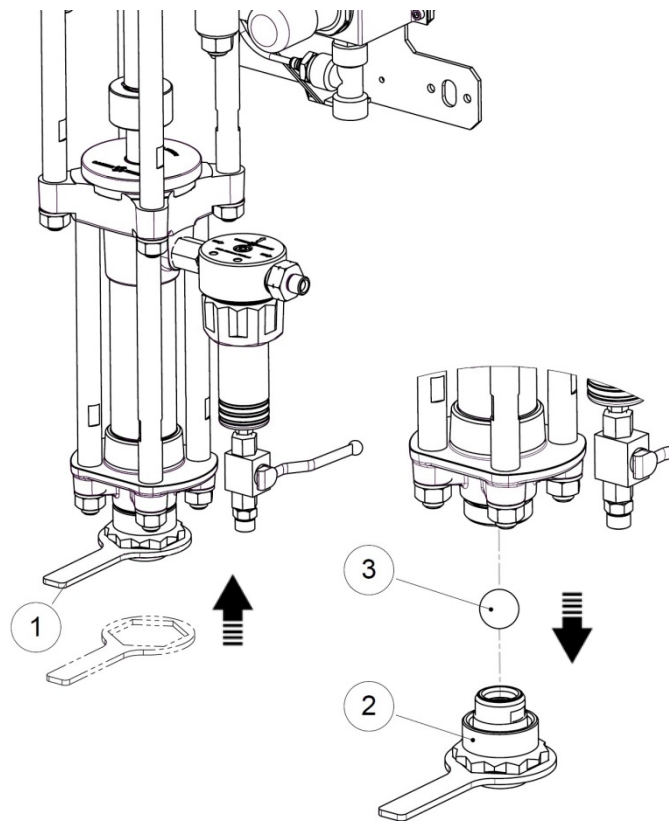

Clean and / or replace the ball + carbide seat with rod option

If cleaning and or replacement ball + seat carbide with option rod

With the filter key (1):

- ✓ Unscrew the nut from the pump foot (2),

And,

- ✓ Pull out the assembly (2) from the bottom.
- ✓ Remove the ball (3).

Tools needed



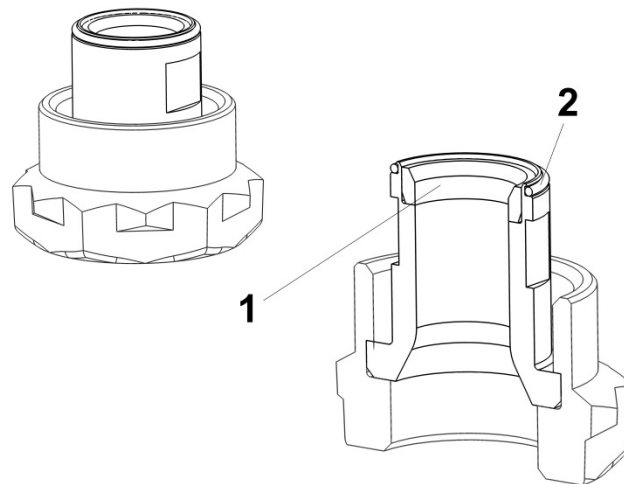

Cleaning the carbide seat and changing the seal

Clean the carbide seat (1) with a solvent-soaked cloth.

To change the seal (2)

- ✓ Remove the seal with a flat screwdriver and replace it.

To change the carbide seat (1):

- ✓ Replace the entire assembly.

Tools needed



**Kluber petamo
HY 133N**

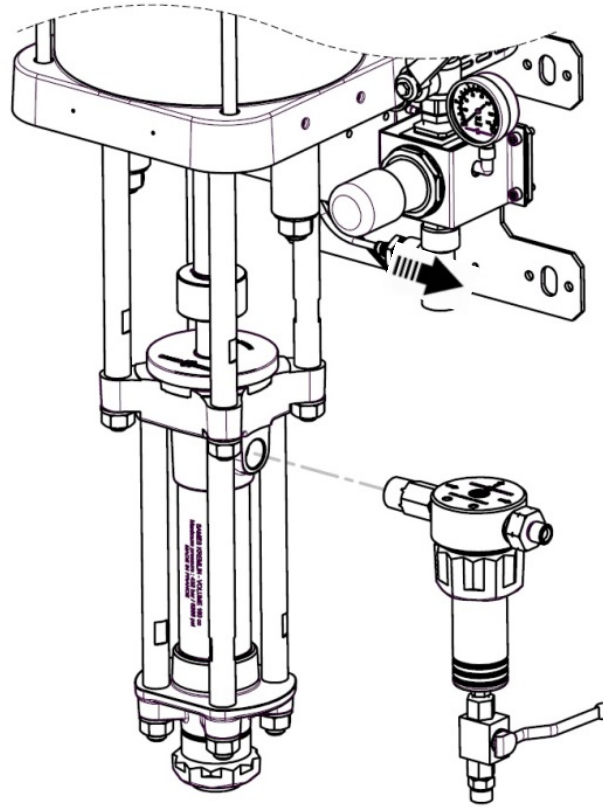

-
- ✓ Unscrew all the filter part (option) with a 27 mm open-end wrench (unscrew at the fitting).

Tools needed

27



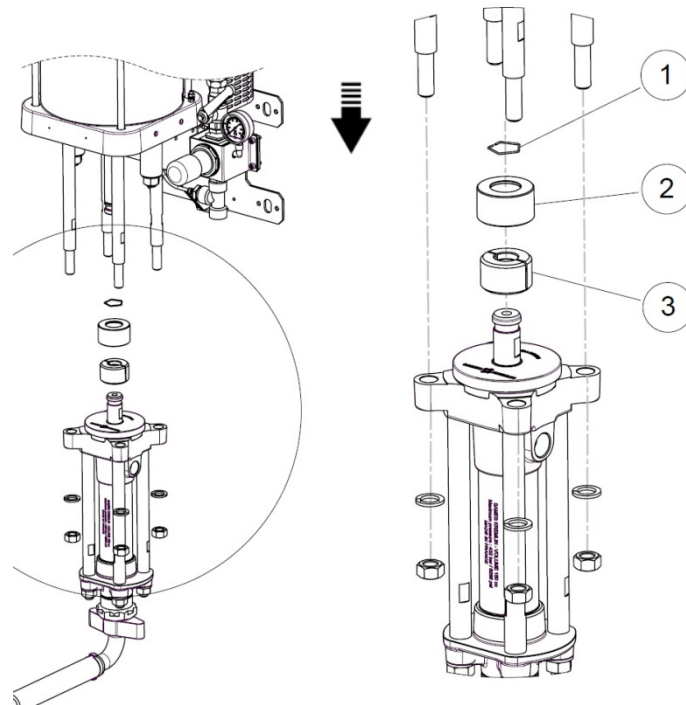

- ✓ Disengage the axle brake (1) above the locking ring (2) and disengage the coupling nuts (3).

- ✓ Unscrew the 4 nuts and the washers with a spanner of 24 mm.



Attention: Good support fluid section (fluid section weight: 11 kg / 24.25 lbs).

- ✓ Disconnect the motor from the fluid section (see disconnecting the motor)

Tools needed

24



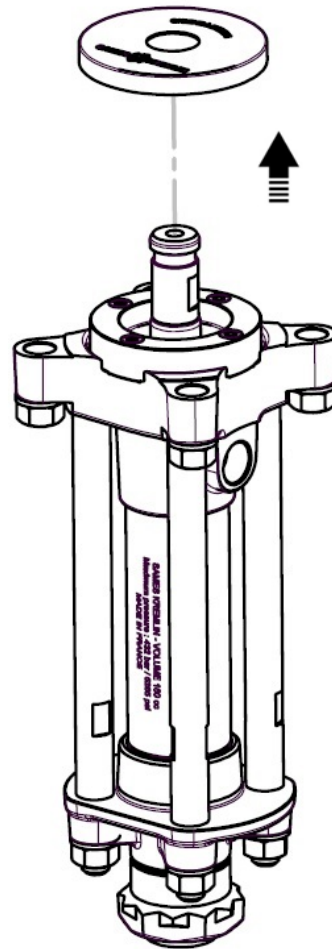

-
- ✓ Manually remove the cover.
-

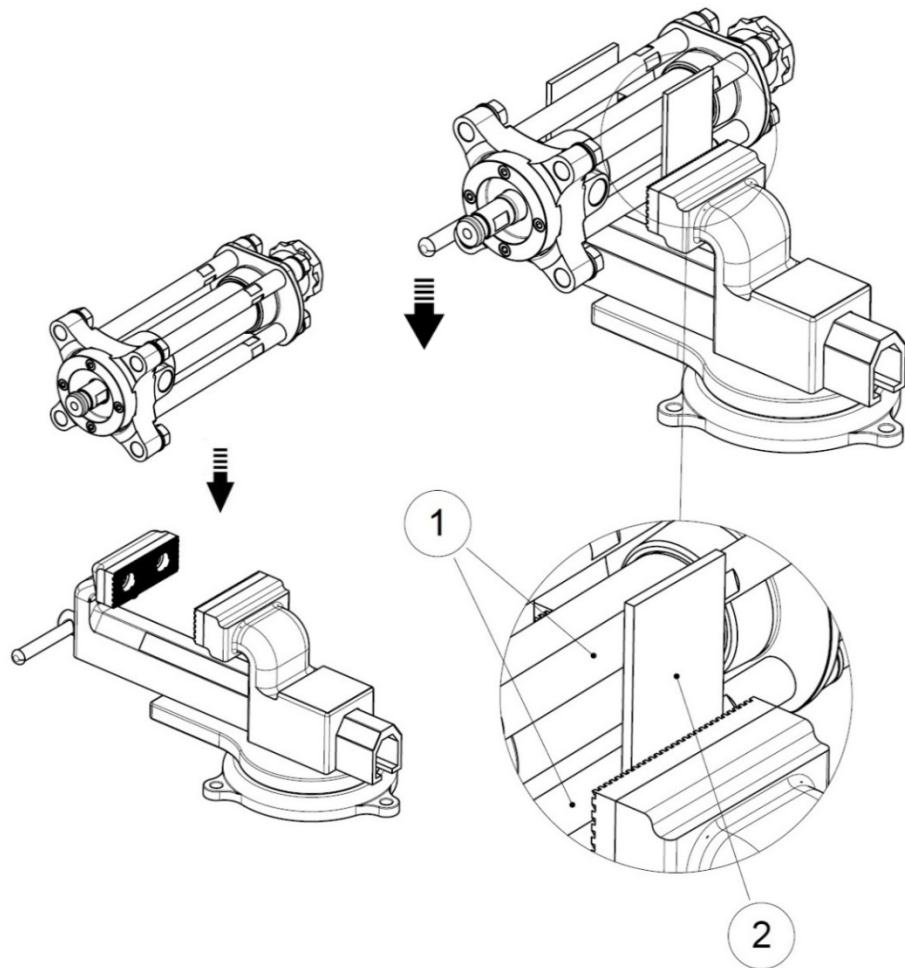

✓ Manually:

- Position the fluid section assembly in the jaws of the vice, in horizontal position, at the tie rods(1). (Weight of the fluid section unit = 11 kg / 24.25 lbs).
- Put martyr's wedges (2) and tighten the vice slightly.

Tools needed



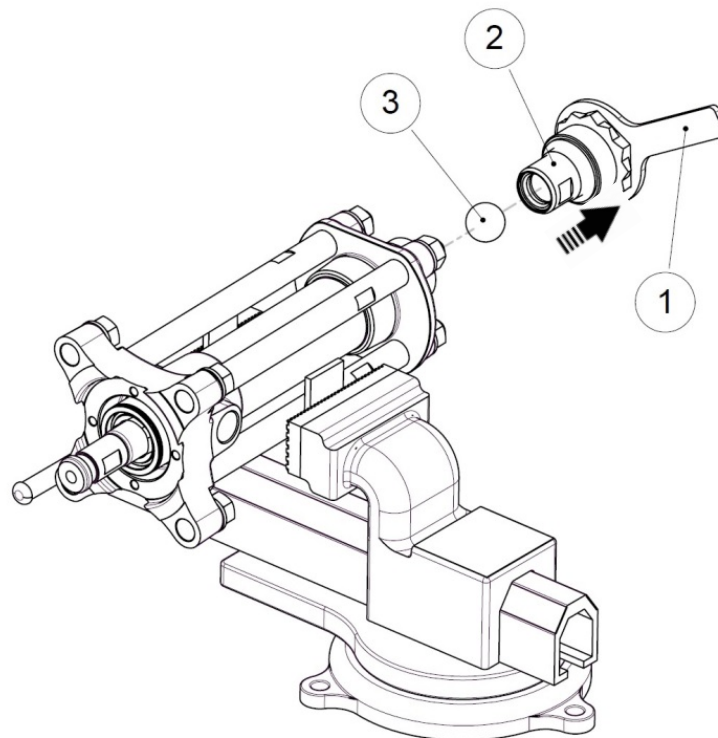

To remove the pump foot:

- ✓ Unscrew the nut with the filter key (1)
- ✓ Remove the assembly (2) and the ball (3).

Tools needed

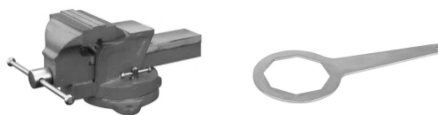

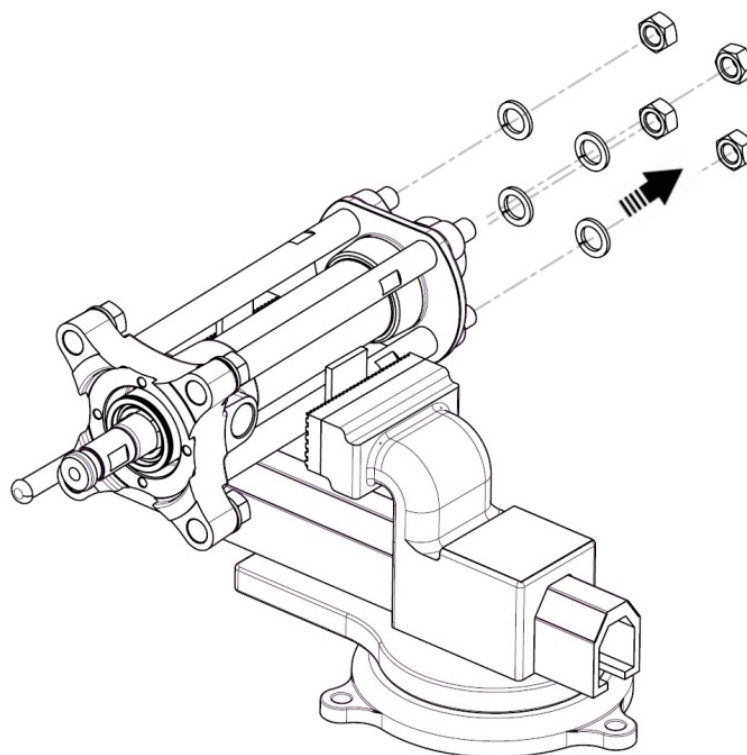

- ✓ Unscrew the 4 nuts with a spanner of 24 mm open-end wrench and the washers.

Tools needed



24



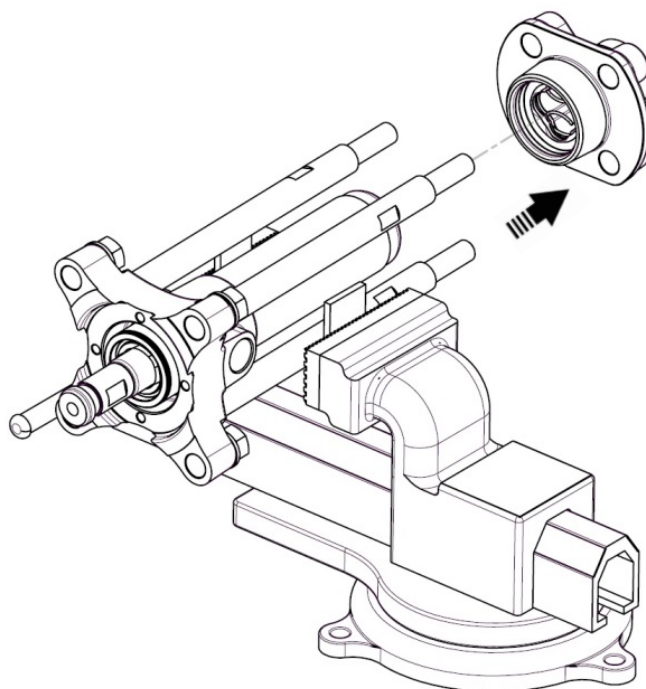

-
- ✓ With a mallet, remove the valve body with snap ring.

Tools needed

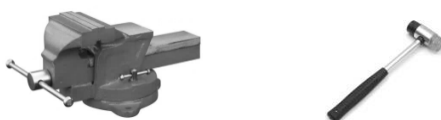

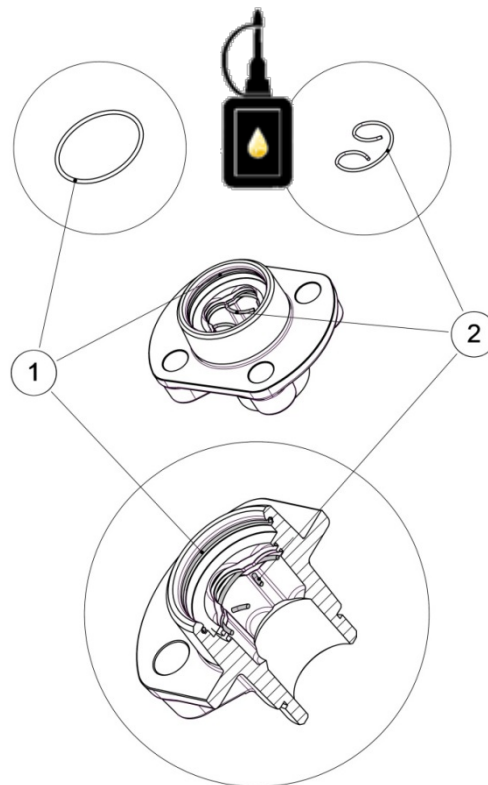

In case of disassembly stop ring

- ✓ Manually, press the snap ring out of its seat and change the workpiece.

In case of change position of the snap ring

- ✓ Manually, press the snap ring out of its seat and change position.

When changing the PTFE seal 909420311

- ✓ Remove the gasket with a flat screwdriver and replace it manually in the groove and grease.

Tools needed



**Kluber petamo
HY 133N**

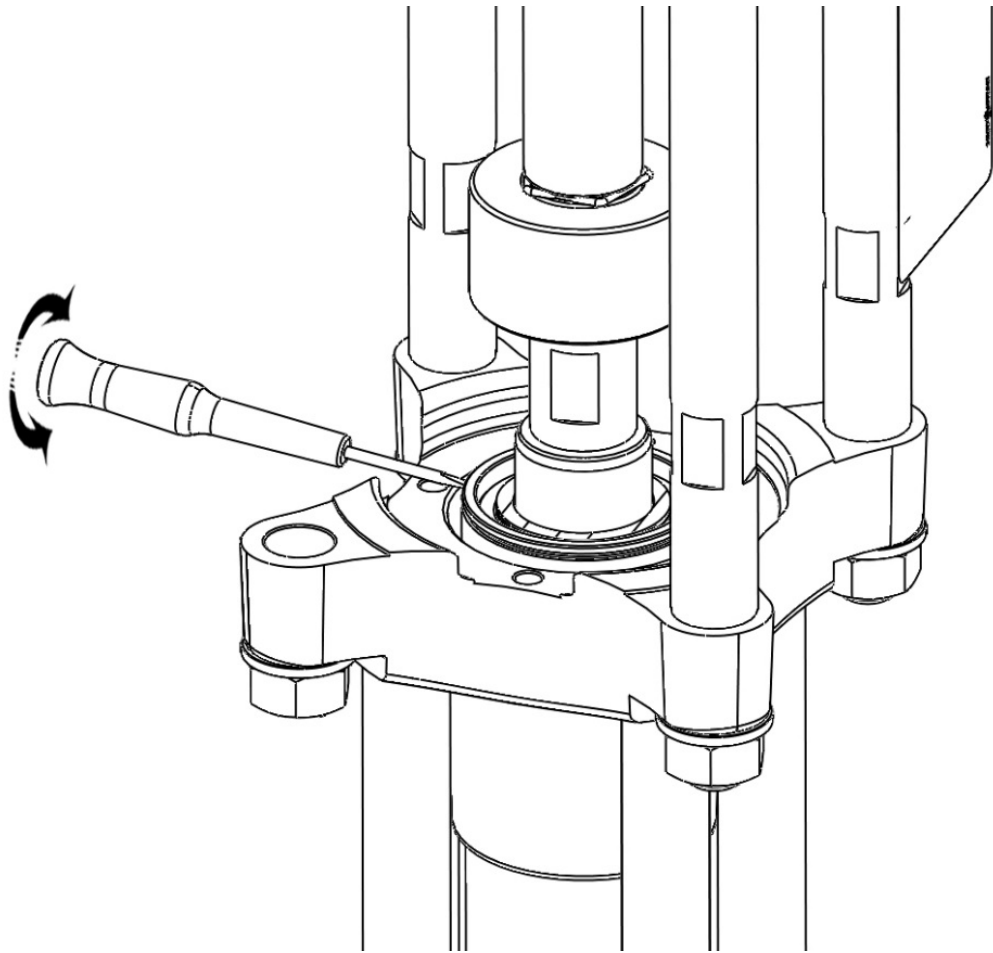

In case of no prior change of the upper joints

- ✓ Unscrew the 4 screws CHC with a key BTR of 6 mm.
- ✓ Remove the flange manually.
- ✓ Remove (Cartridge + spring cartridge + spring + press male seal + 8 V seals) with a flat screwdriver, positioning it in the groove of the cartridge body.

Tools needed

6



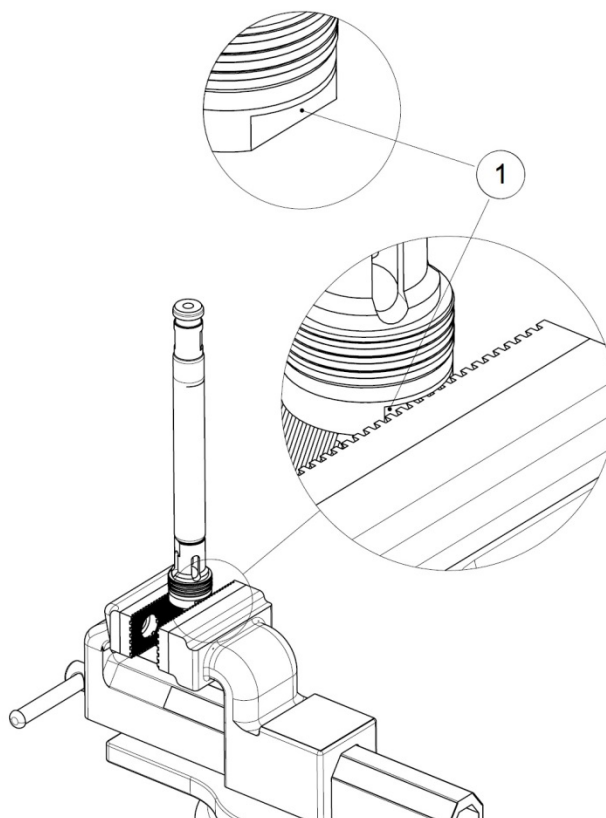

If change of seals

- ✓ Position the piston in the jaws of the vise at the flats of part.

Tools needed



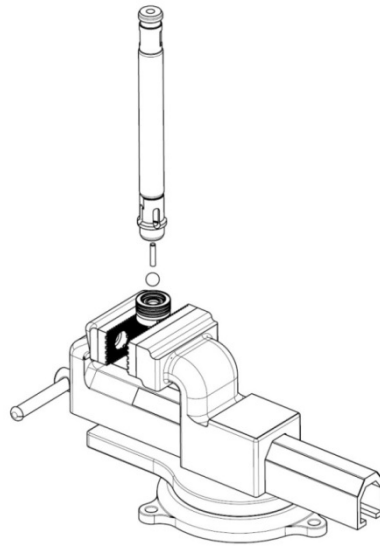

-
- ✓ With a flat wrench:
 - Unscrew the discharge valve at the flats part of the piston fitted.
 - Change the seals by replacing them with new ones (grease).

If change of the pin

- ✓ Position the piston in the jaws of the vice at the flats of the discharge valve.
- ✓ With a flat wrench:
 - Unscrew the discharge valve at the flat part of the piston fitted.
 - Unscrew the discharge valve of the piston, resting on the two flats.

With a pin hunt:

- Remove the pin.

Tools needed

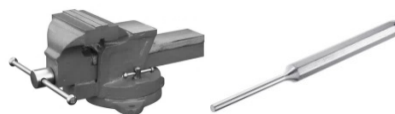

In case of replacement of the pin

- ✓ Replace the pin with a new one, holding it with a mallet.
- ✓ Depending on the viscosity of the product and if the lifting of the ball is greater:
 - Replace the pin L=30 mm with pin L=28 mm or L=24 mm depending on the viscosity of the product (spare part).

Material type	Suction positioner	Exhaust pin size	Comment
Liquid material	Top position	L24 or L28 pin	Longer travel possible to empower the suction
Viscous material	Bottom position	L30 Pin	Avoid the ball to lift too much to shorter the closing time due to viscosity Each pump are mounted as follow from the factory

In the event of a discharge valve + ball change

Tip: It is recommended to change both at the same time

- ✓ Position the piston in the jaws of the vise at the flats of the discharge valve.

With a flat wrench

- ✓ Unscrew the discharge valve at the flat part of the piston fitted.
- ✓ Unscrew the discharge valve of the piston, resting on the two flats.
- ✓ Loosen the vice and recover the ball + the discharge valve.
- ✓ Change the two pieces.

When changing the seal 909420311 (between flange)

- ✓ Extract the seal with a flat screwdriver.
- ✓ Then replace a new gasket and grease the gasket on the contour more evenly.

-
- ✓ Manually remove the product cylinder.
 - ✓ To take off the cylinder:
 - type in the mallet presence painting)

-
- ✓ Using the vice, and tightening the clamp vertically:
 - Unscrew the 4 tie rods with a 19 mm wrench.

Reassembly



Attention

Vertical winding - attention tightening torque

-
- ✓ When coupling the motor with the fluid section:
 - place the nuts on the tie rods without tightening them.
 - ✓ Beat the vacuum pump (0,5 bar 7.25 psi max) (5 ways).
 - ✓ Tighten the nuts diagonally to a torque of 100 N.m.

Tools needed

19



19



17.2 Reassembly

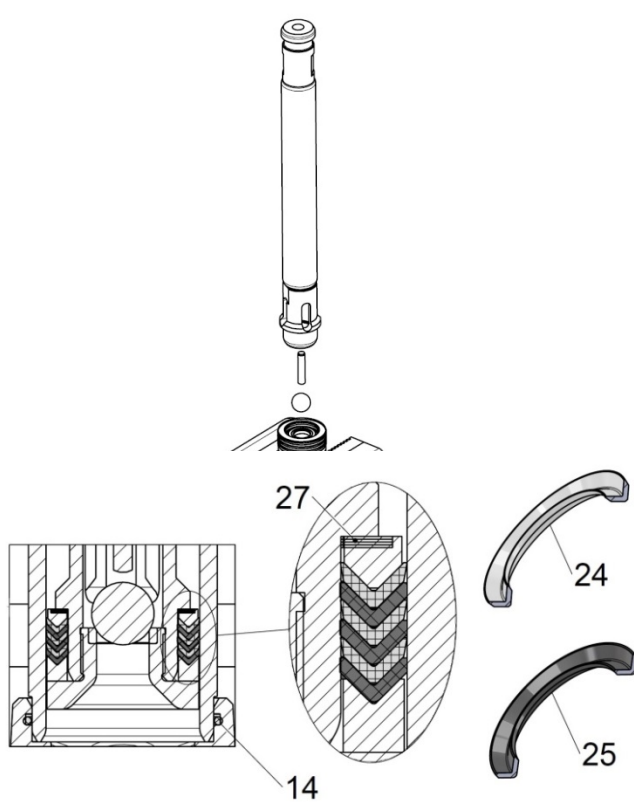

- Replace together the 4 lower spacers (27) and the new seals (24 and 25) (grease),
- Position the pin in the flap.
- Put the ball in place
- Screw the discharge valve manually onto the flat surface of the equipped piston.

Tools needed



**Kluber petamo
HY 133N**

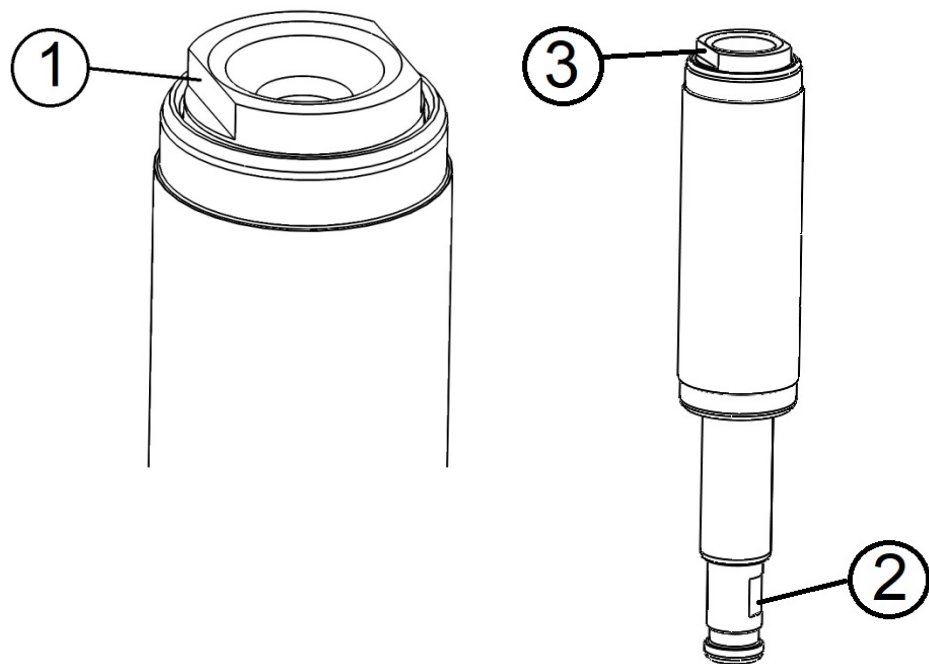

- ✓ Grease the inside of the cylinder,
- ✓ Place the equipped piston and seat assembly in the fluid cylinder (discharge valve first),
- ✓ Push the flats (1) of the discharge valve out of the cylinder,
- ✓ Secure the stem with a 24 mm open-end wrench, and tighten the discharge valve to 150 Nm with a 32 mm torque wrench.

Note: Make sure that when tightening, the rod (2) remains coaxial with the cylinder (3).

Tools needed

24



32



**Kluber petamo
HY 133N**

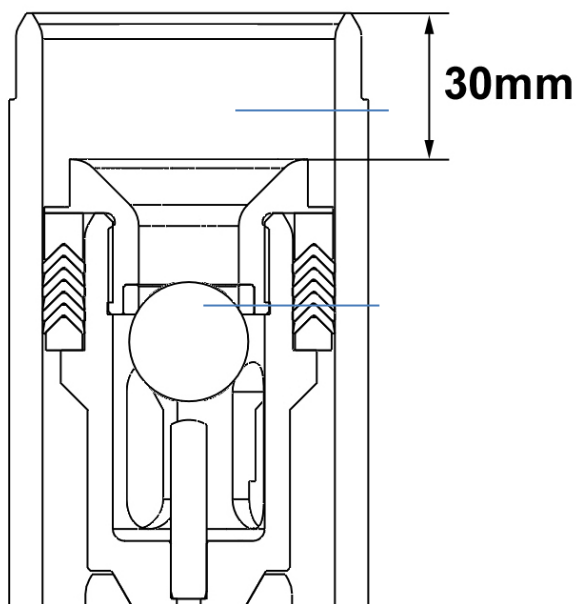

- ✓ Reassemble the rod in the produced cylinder using a mallet, respecting the above dimension.

Tools needed



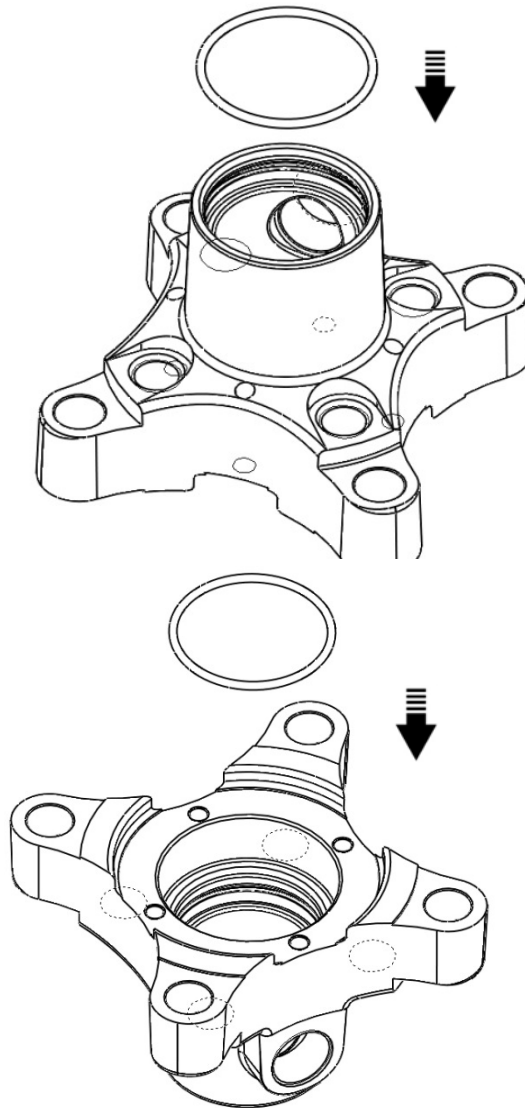

-
- ✓ Manually position the O-rings in the flange.
 - ✓ Grease the seals.
-

Tools needed



**Kluber petamo
HY 133N**

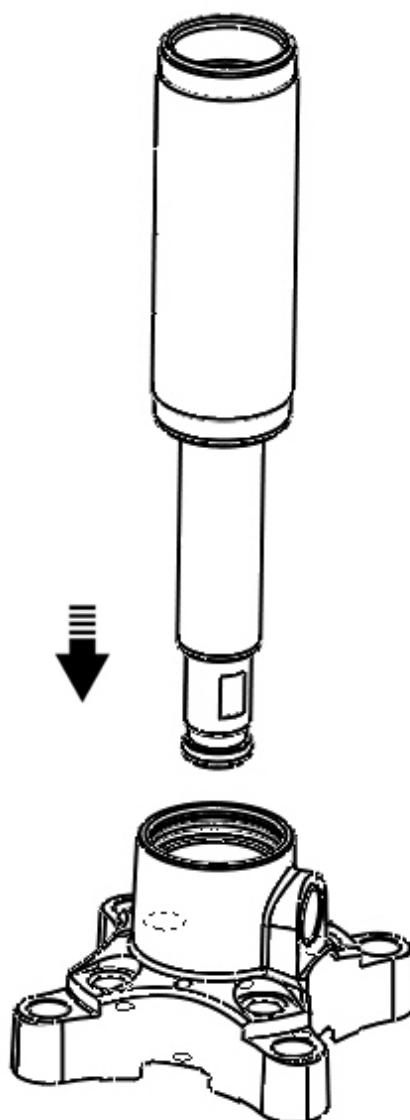

-
- ✓ Insert the fluid cylinder into the flange.
-

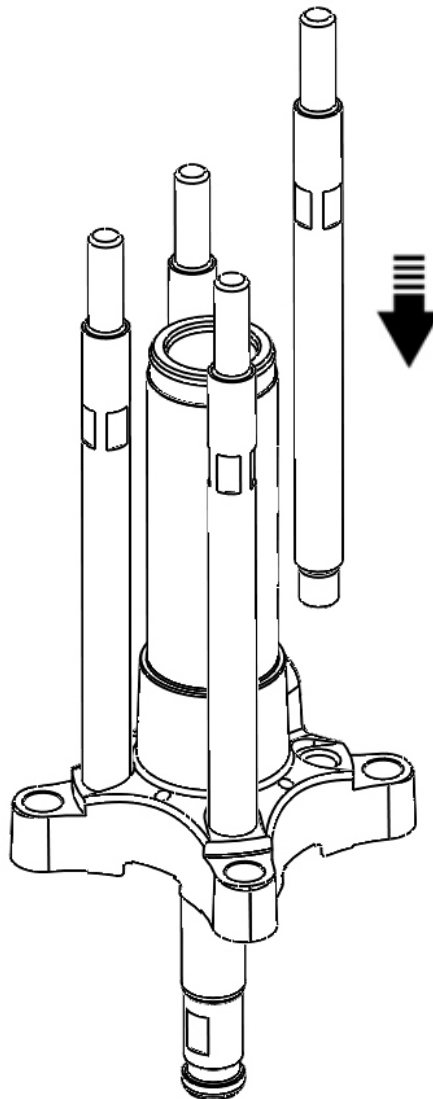

- ✓ Screw the 4 tie rods with a 19 mm torque wrench to the 100 N.m. torque.

Tools needed

19



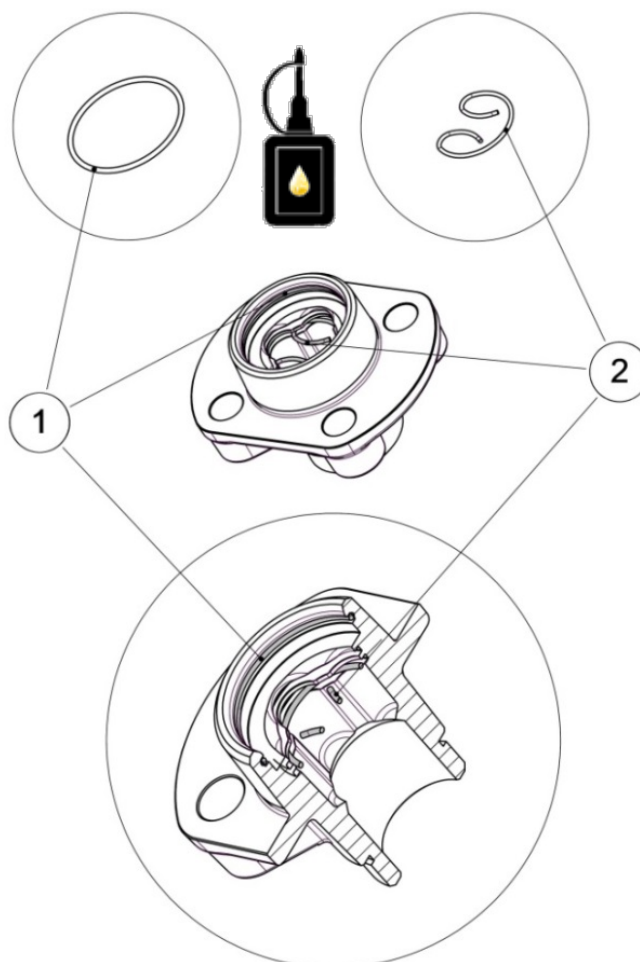

- ✓ Manually press the locking ring (2) into its seat at the desired height.
- ✓ Manually place the O-ring (1) and grease.

Tools needed



**Kluber petamo
HY 133N**

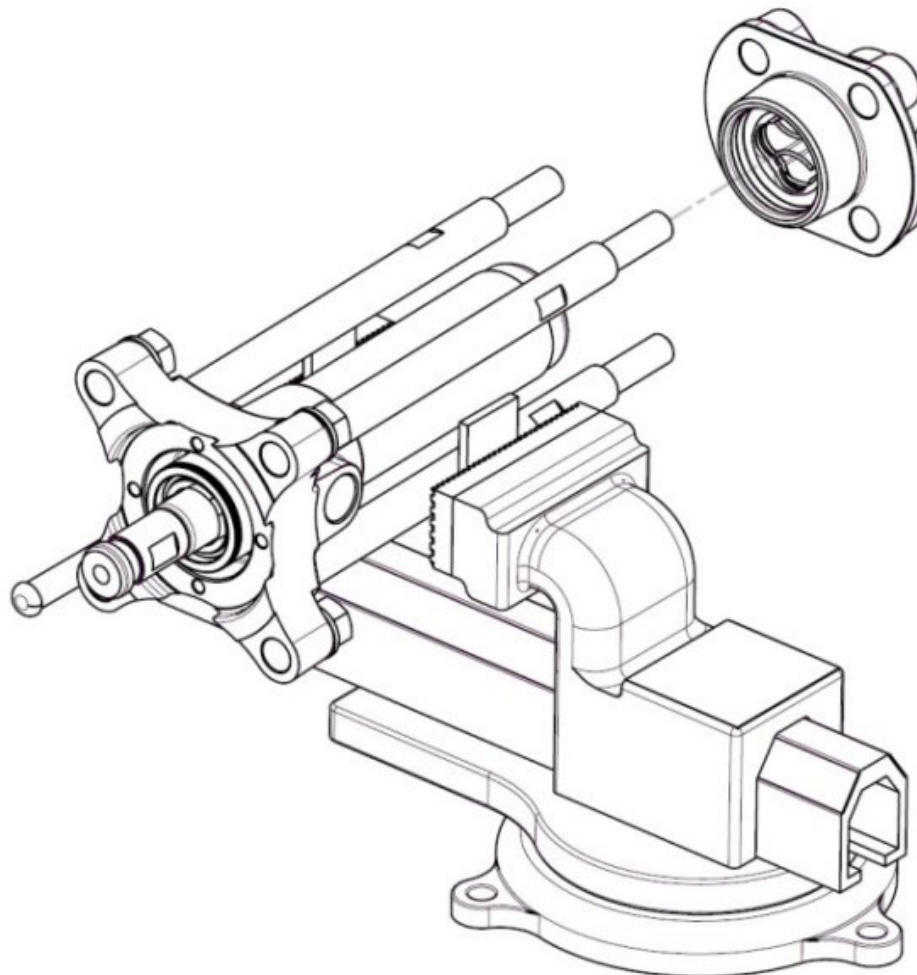

-
- ✓ Use a mallet to insert the valve body with the locking ring.
-

Tools needed



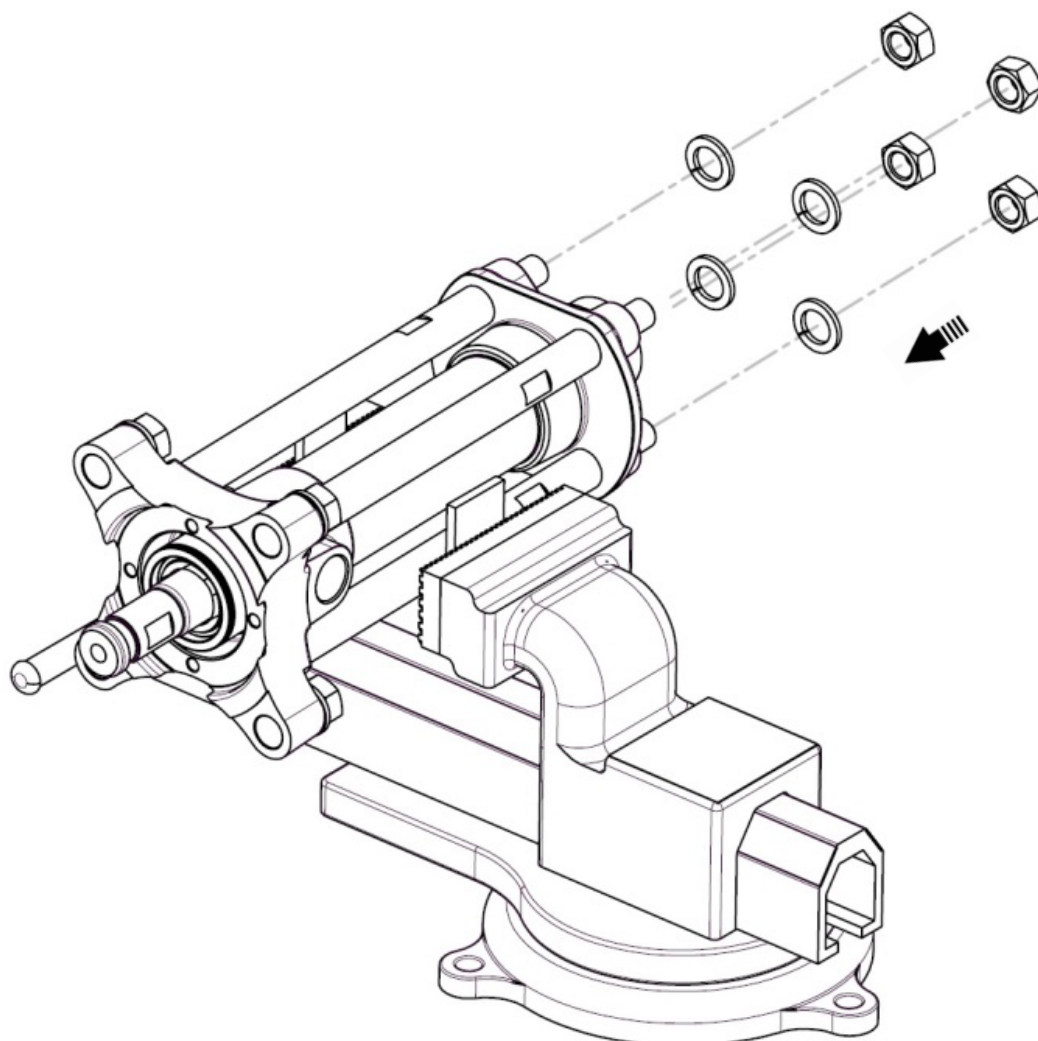

- ✓ Insert the washers.
- ✓ crew the 4 nuts with a 24 mm torque wrench to the 100 N.m. torque.

Tools needed

24



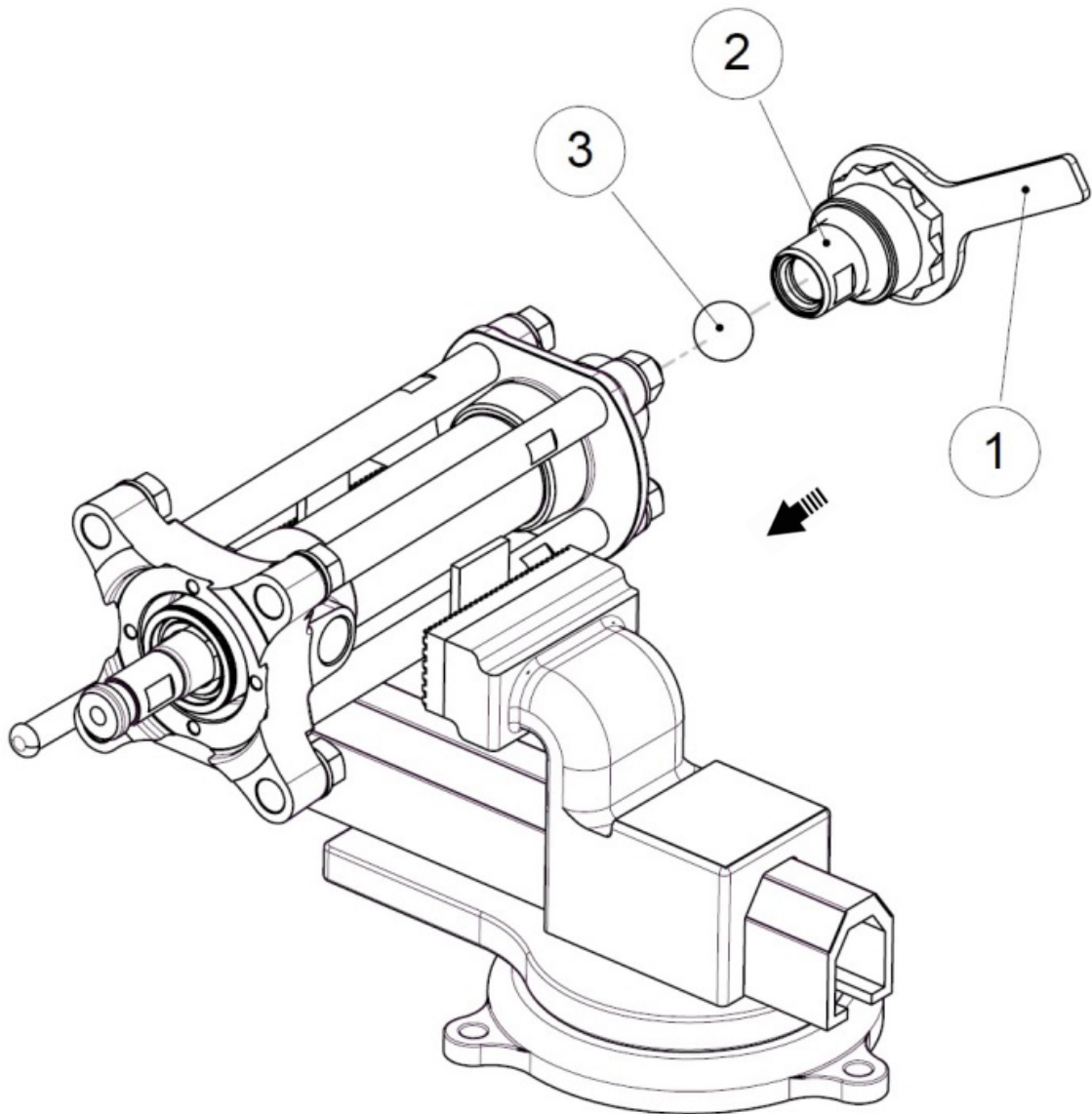

- ✓ Manually place the ball (3)
- ✓ Screw on the nut with the wrench (1)
- ✓ Loosen the key (1) with a mallet

Tools needed



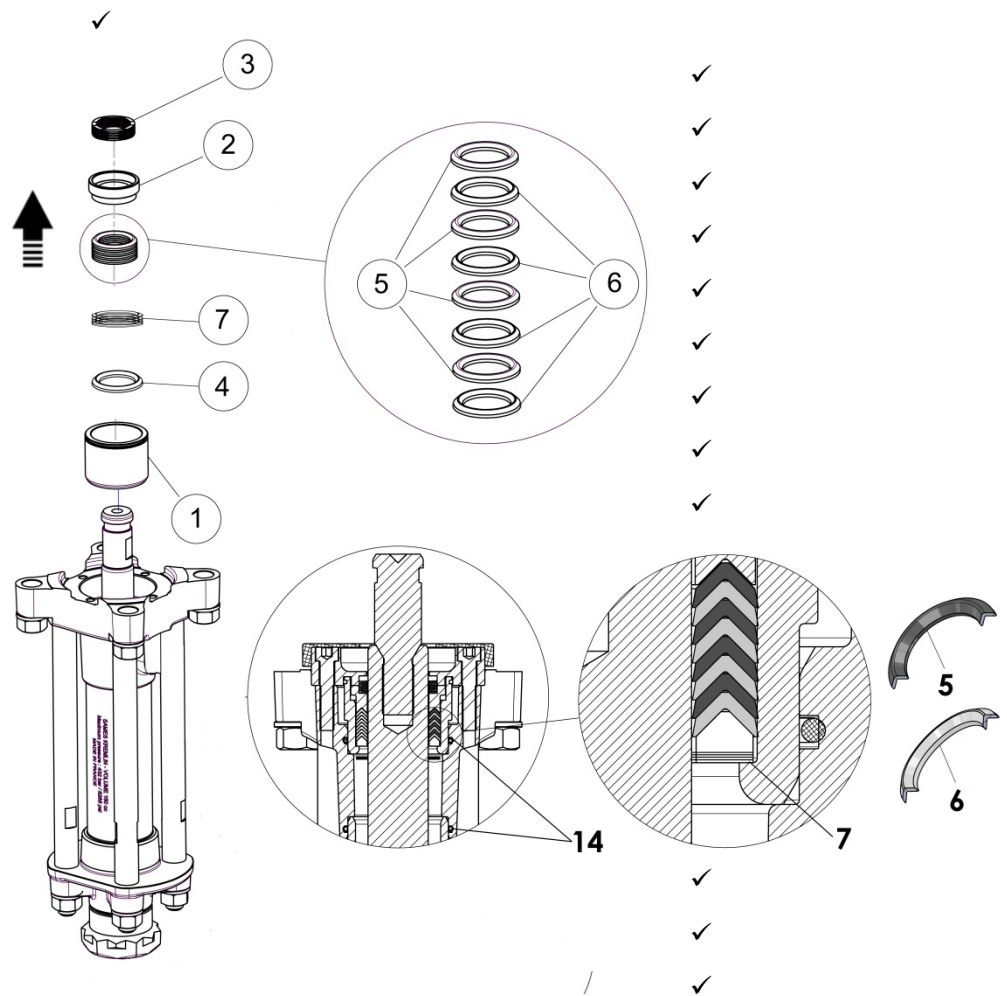

- ✓ Stack the seals (5 and 6) and the 4 spacers (7) between the parts (2 and 4).
- ✓ Grease the rafter joints inside and outside.
- ✓ Place the rafter piece seal assembly (spring cartridge - male seal press) into the cartridge (1).
- ✓ Place the cartridge assembly in the flange in contact with the piston.
- ✓ Place the spring (3).

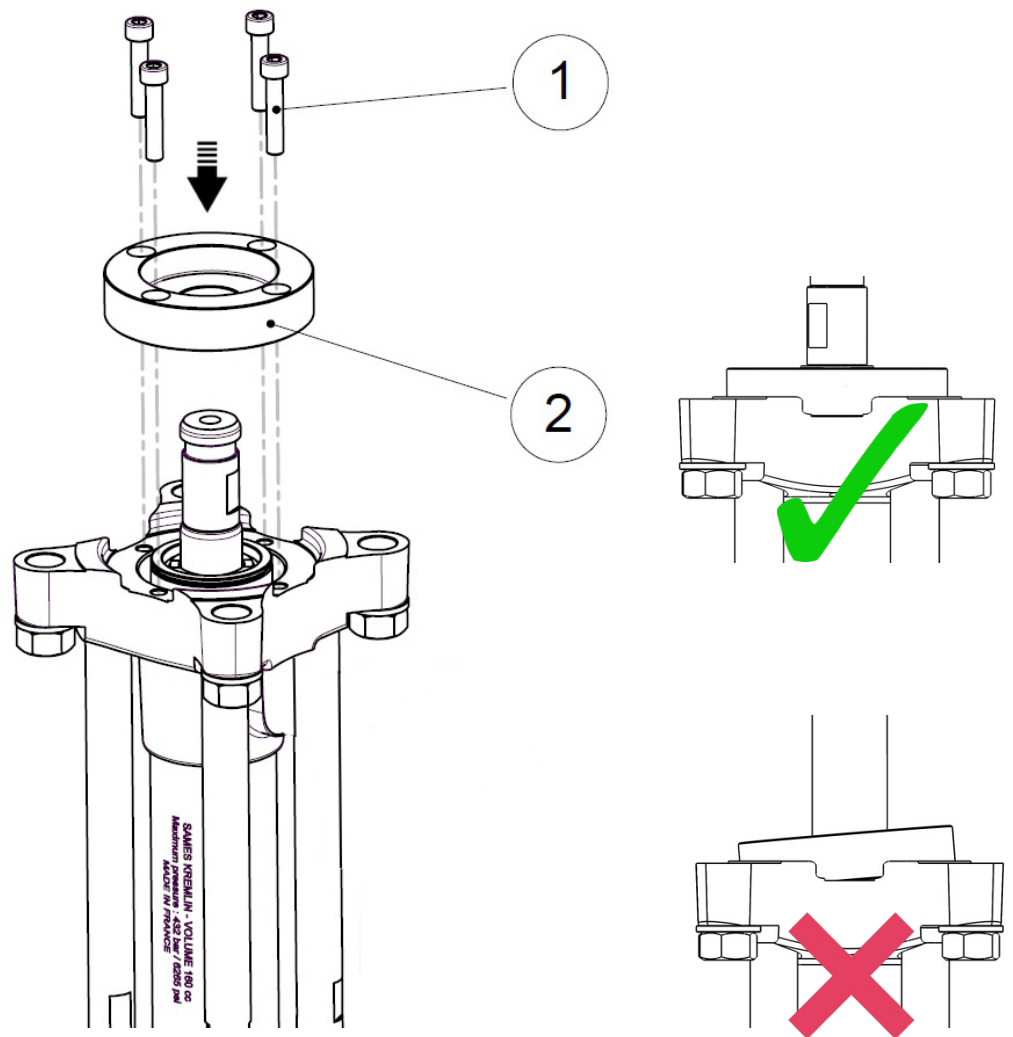

- ✓ Manually place the flange.
- ✓ crew the 4 CHC screws together with a 6 mm BTR wrench.

Tools needed



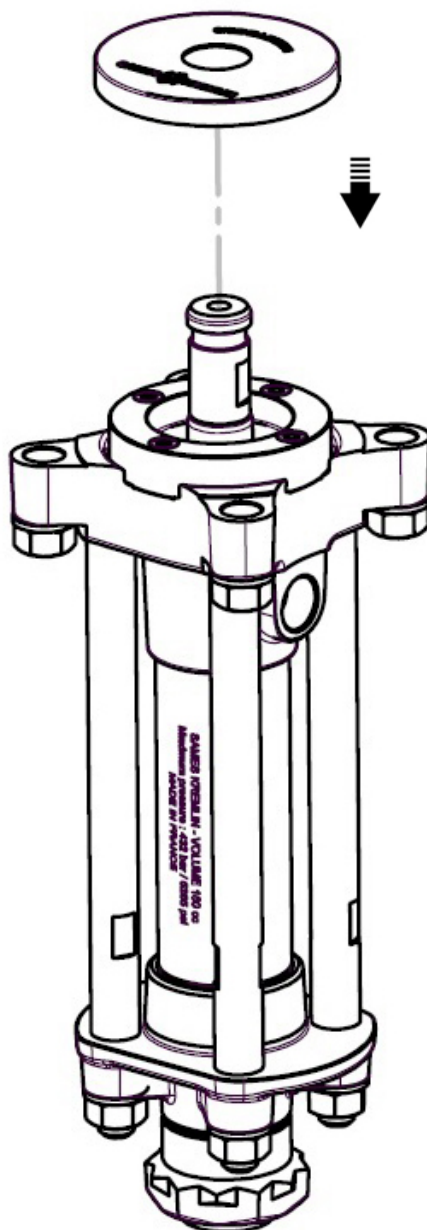

-
- ✓ Put the cover on.
-

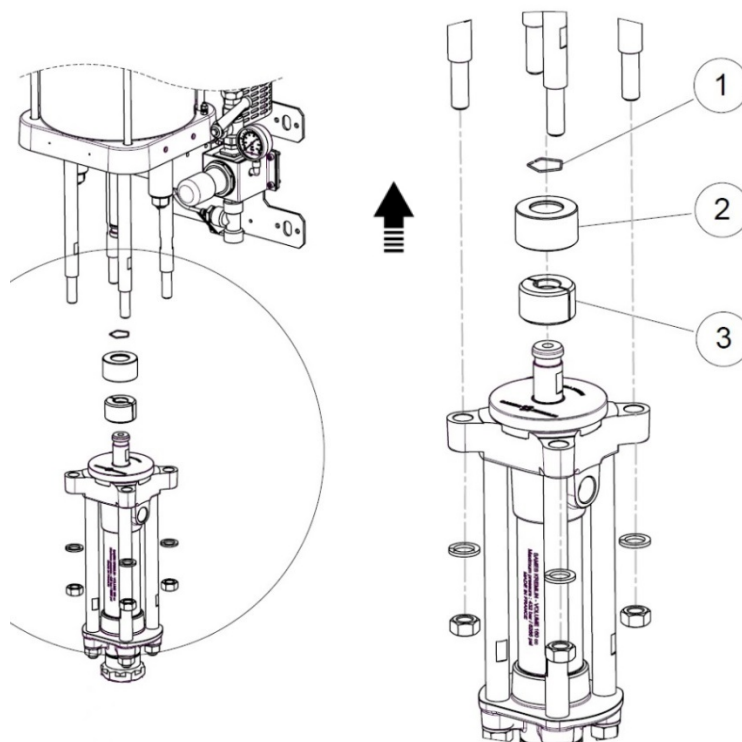

- ✓ Position the fluid section under the motor.
- ✓ Position the washers and tighten the nuts manually.
- ✓ Manually lift the motor rod.
- ✓ Position the axle brake (1) and locking ring (2) on the motor rod.
- ✓ Lower the motor rod again when in contact with the fluid section piston.
- ✓ Place the coupling nuts (3).
- ✓ Lower the locking ring (2) and position the axle brake (1) in the groove
- ✓ Beat the vacuum pump (0.5 bar / 7.25 psi max) (5 round trip).
- ✓ Tighten the 4 nuts crosswise with a 24 mm torque wrench to 100 N.m. torque.

Tools needed

24



18 Installation of the wall pump

- ✓ The wall mounting procedure is carried out via a lifting device.
 - ✓ Sling on the pallet, the pump assembly and wall bracket with lifting means, by the motor ring.
-
- ✓ Present the pump and support assembly on the wall or metal frame
-
- ✓ Secure the pump and support assembly with suitable dowels or bolts
-
- ✓ Once set, remove the slings.
-

Tools needed



19 Spare parts

Use only genuine SAMES KREMLIN accessories and spare parts designed to withstand the pump's operating pressures.

19.1 Motor, Model 7000 stroke 120

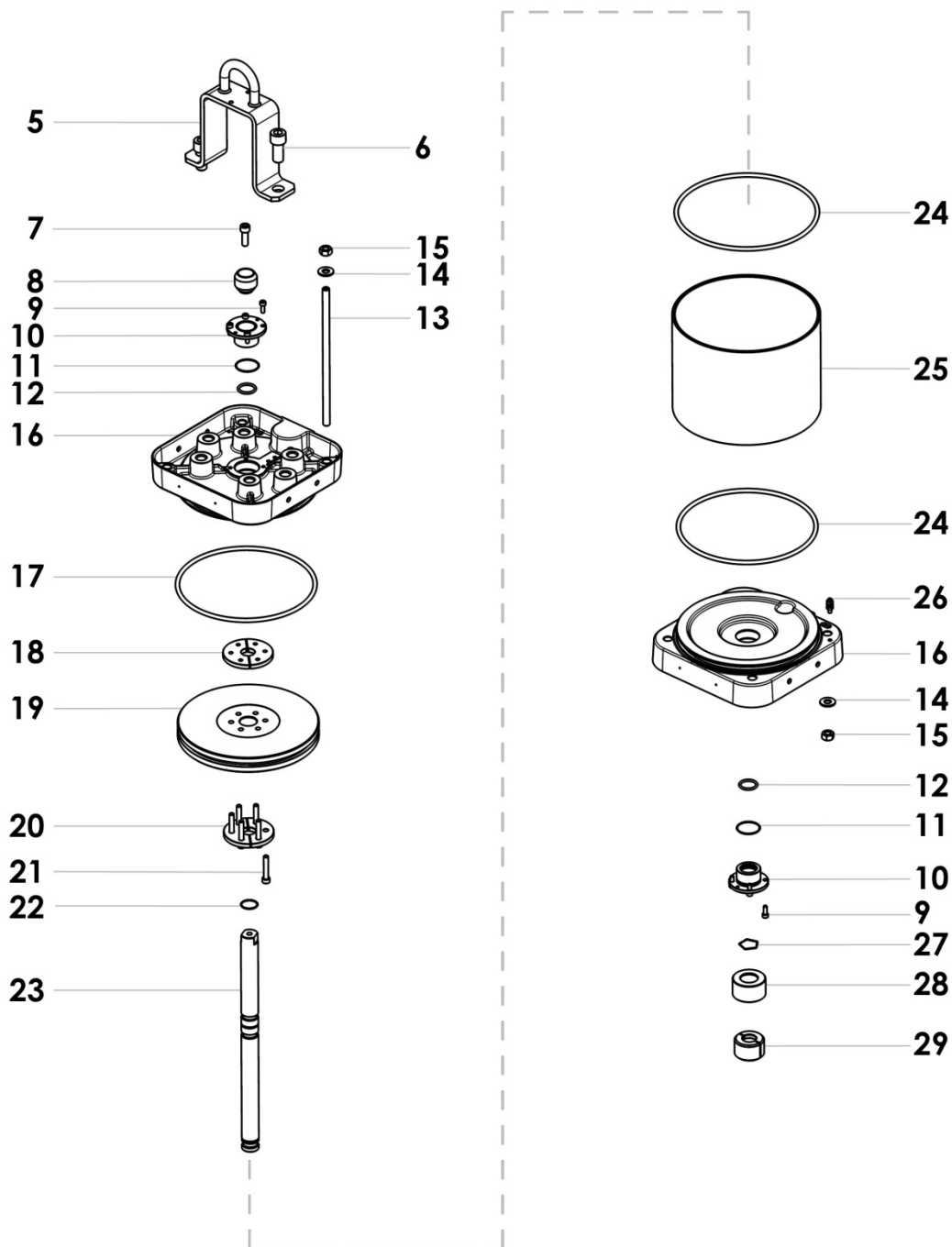

Ind	# Reference	Description	Qty
1	930 151 198	Screw CHc M 8x16	2
2	963 020 019	Washer ZU 8	2
3	146 371 010	Cover	1
4	901 180 024	Grounding terminal equipped	1
5	146 371 008	U-bolt	1
6	930 151 507	Screw CHc M 18x40	2
7	88 189	Screw CHc M 10x30	1
8	209 364	Cam	1
9	933 151 196	Screw CHc M 6x16	4
10	146 320 095	Bearing	2
*11	84 193	Outer bearing seal	2
*12	85 022	Inner bearing seal	2
13	146 371 013	Pulling (x4)	1
14	963 040 023	▪ Washer MU 12	8
15	953 010 023	▪ Nut HM 12	8
16	146 371 003	Flange	2
*17	909 130 378	Piston seal	1
18	205 593	Counter flange (2 parts)	1
19	209 363	Piston	1
20	205 592	Stop flange (2 parts)	1
21	88 735	Screw CHc M 8x45	6
*22	909 420 225	Piston rod seal	1
23	146 371 001	Piston rod	1
*24	84 194	Flange seal	2
25	205 209	Cylinder	1
26	104 790	Grounding terminal	1
27	90 165	Ring	1
28	205 212	Closing ring	1
29	205 211	Shell (2 parts)	1

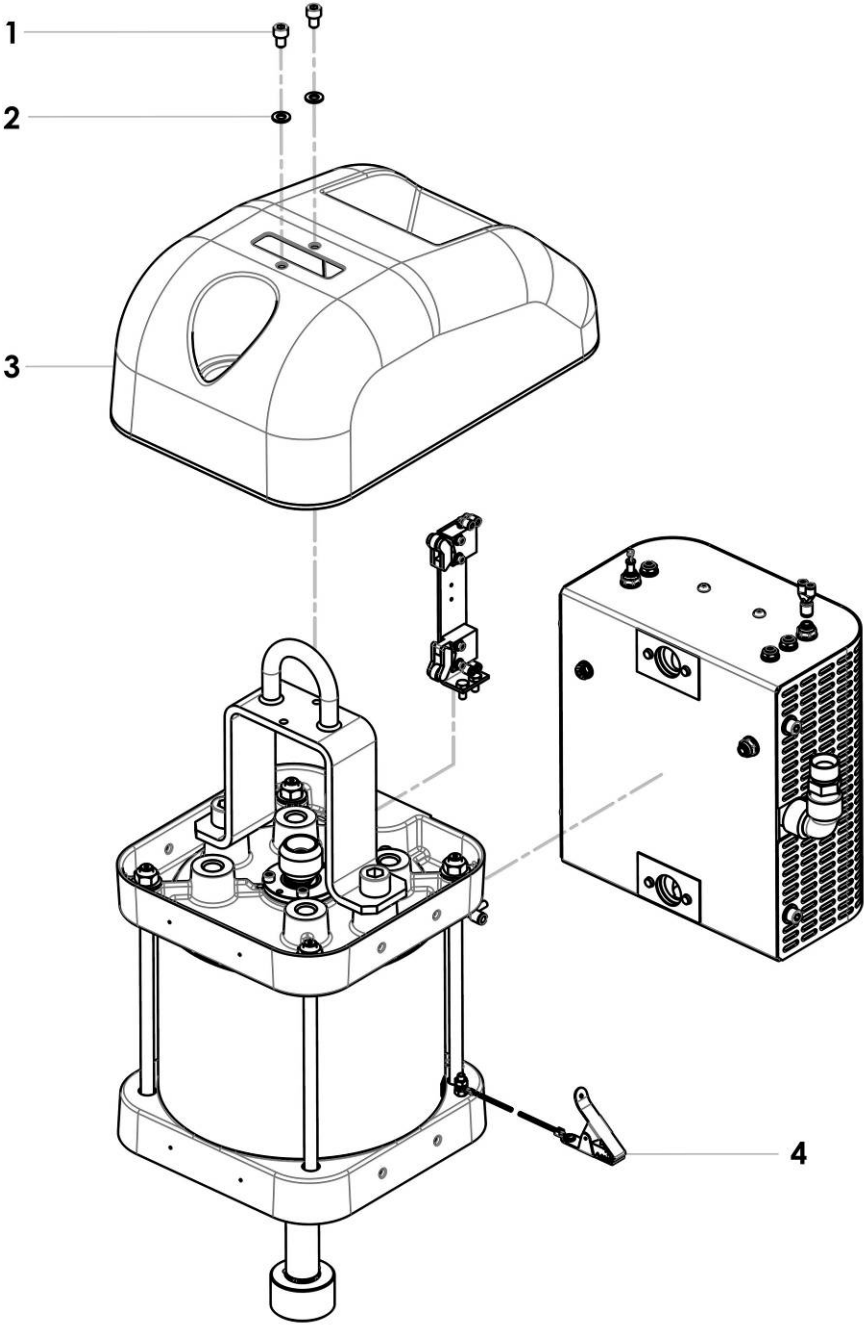

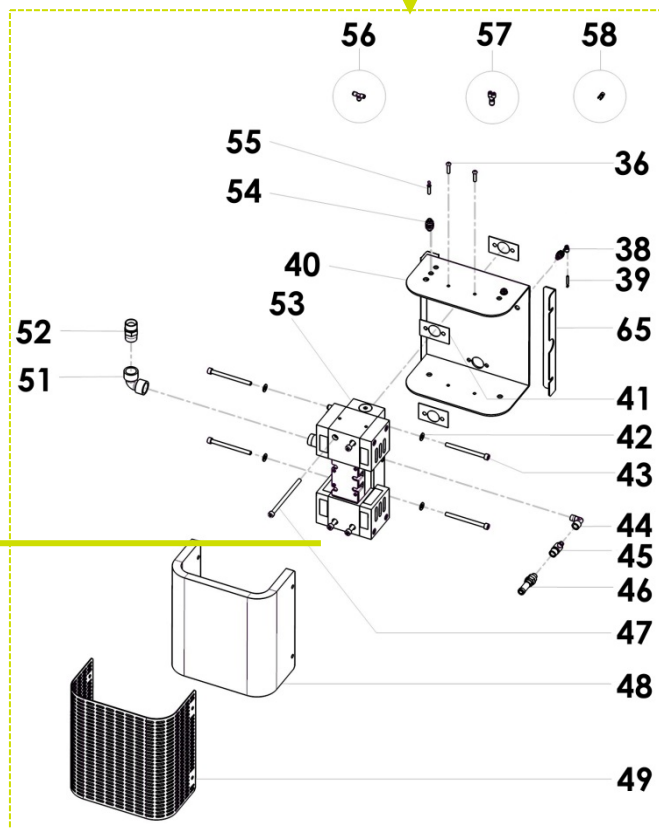
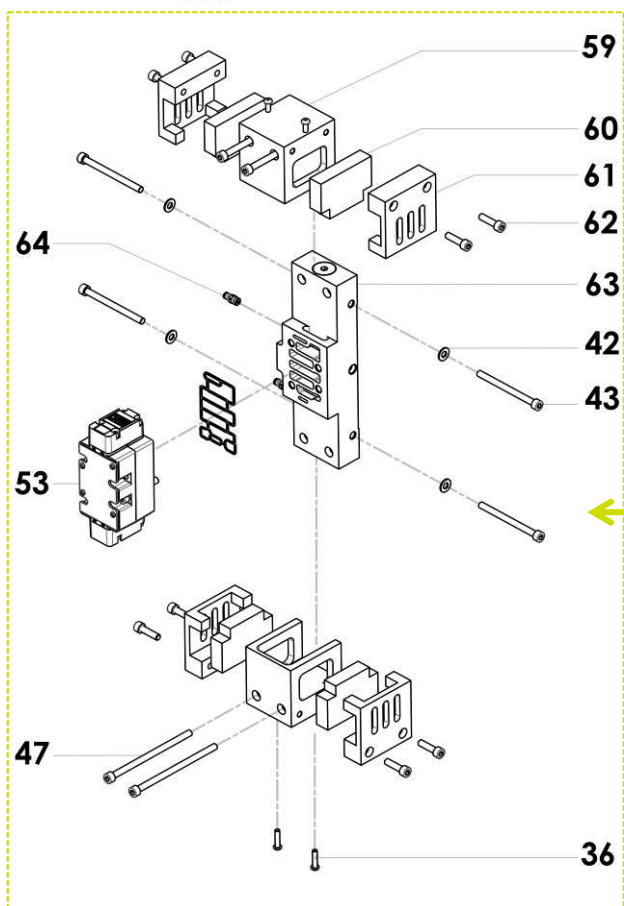
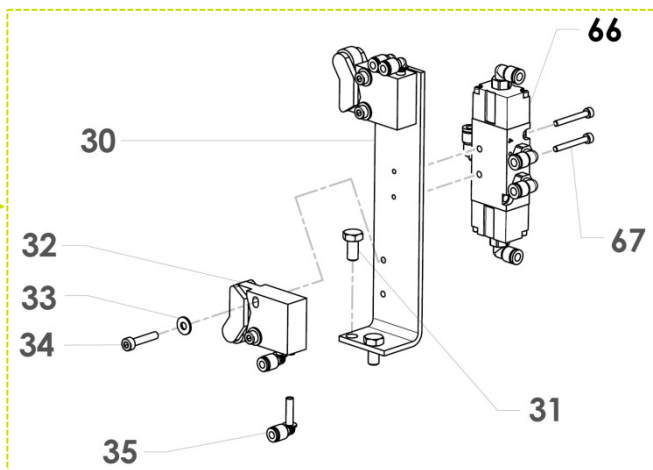
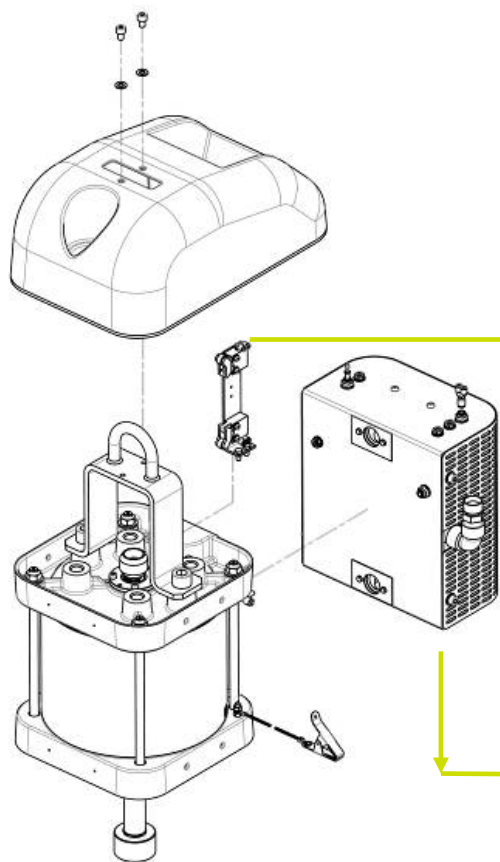

Ind	# Reference	Designation	Qty
30	209 358	Bracket	1
31	933 011 170	Screw HM 6x12	2
*32	151 800 002	Switch (x 2)	1
33	963 040 012	Washer MU 4	4
34	933 151 273	Screw CHc M 4x20	4
35	905 120 983	Elbow MFT 2x4	4
36	934 081 332	Screw Hc M 6x25	4
38	905 120 910	Crossing of partition	1
39	905 120 937	Tube stopper	2
40	146 371 027	Muffler support	1
*41	205 213	Base gasket	4
42	963 040 019	Washer MU 8	4
43	NC / NS	Screw CHc M 6x100	4
44	552 431	Elbow 1/4 "MF	1
45	552 542	Fitting 1/4 "G	1
*46	903 080 401	Relief valve	1
47	88 981	Screw CHc M 8x140	4
*48	146 371 024	Muffler foam	1
49	146 371 023	Silencer casing	1
50	905 210 710	Straight fitting MM 3/4 "G	1
51	552 429	Elbow 3/4 "FF	1
52	550 773	Fitting M 3/4 "- M 3/4" BSP	1
*53	903 050 511	Distributor ISO 5/2 - T3	1
54	905 121 114	Crossing of partition	2
55	905 120 924	Tube stopper	1
56	905 120 957	T connection 2.7x4	1
57	NC / NS	Y connection	1
58	91 723	Clip	1
59	146 371 012	Muffler support	2
60	146 371 011	Muffler rigid foam	4
61	146 371 009	Foam support	4

N S: Denotes parts are not serviceable.

Ind	# Reference	Description	Qty
62	88 153	Screw CHc M 8x30	8
63	146 371 005	Socket	1
64	552 251	Fitting 1/8 "G	2
65	146 371 015	Bracket	2
66	91 424	Distributor 5/2	1
67	932 151 326	Screw CHc M 3x25	2

Ind	# Reference	Description	Qty
*	146 371 040	Motor seals kit (ind 11 (x 2), 12 (x2), 17 (x 2), 22, 24 (x 2) 41 (x 4))	1

* Recommended maintenance parts.

N C: Not marketed.

19.2 Fluid section, Model C225

Ref. Fluid section
144050303
144050304
144050305

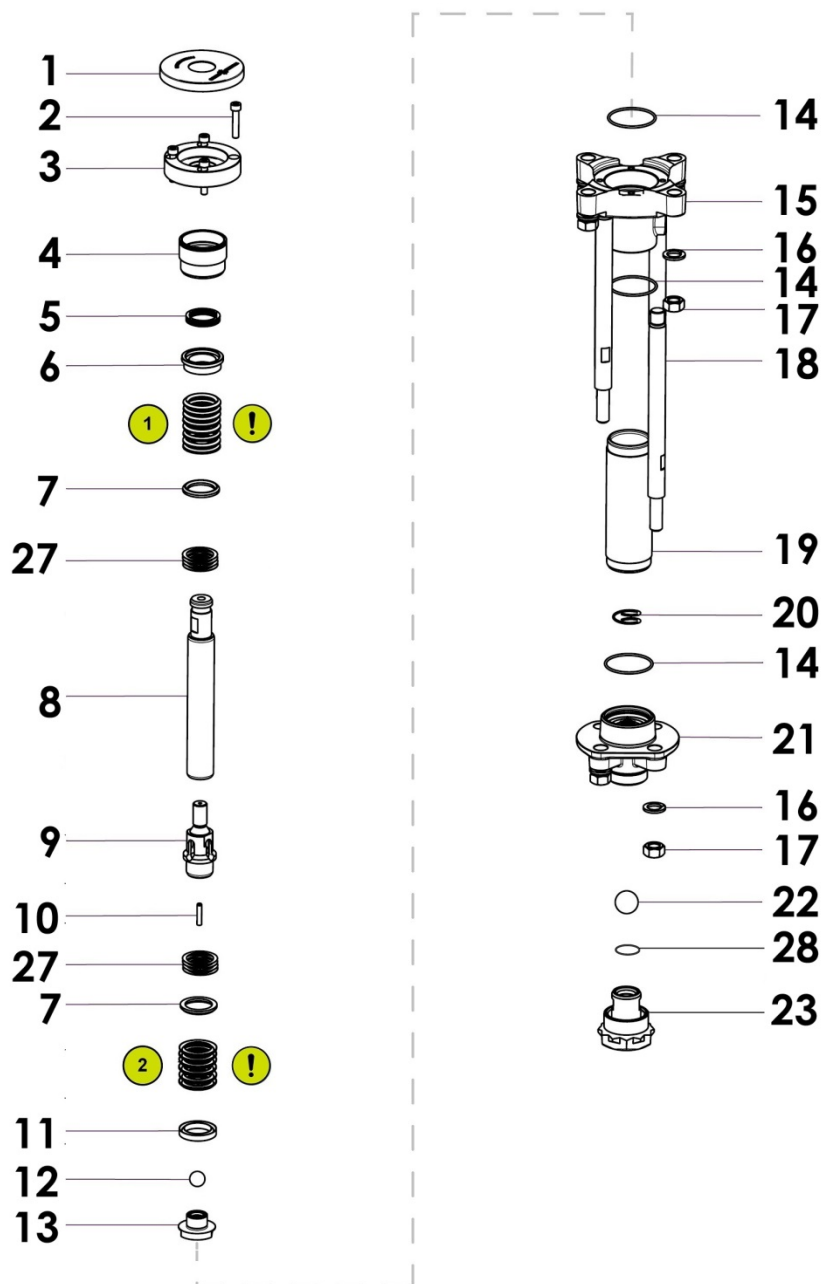

Ind	# Reference	Description	Qty
1	144 050 038	Cover	1
2	930 151 500	Screw CHc M 8x40	4
3*	144 050 015	Flange	1
4*	144 050 016	Cartridge	1
5	150 319 801	Spring	1
6	144 050 033	Spring housing	1
7	209 652	Male joint clamp	2
-*	144 050 013	Assembled material piston	1
8	144 050 010	▪ Chrome piston	1
9	144 050 006	▪ Discharge valve support	1
10	906 250 011	Pin L = 30 mm	1
11	209 651	Female joint washer	1
12	87 320	Ball Ø 20 stainless steel	1
13	144 050 030	Discharge valve	1
14*	909 420 311	PTFE O-ring	3
15	144 050 024	Flange	1
16	NC / NS	Washer	8
17	953 010 025	Nut HM 16	8
18	144 050 014	Pulling	8
19*	144 050 022	Cylinder	1
-*	144 050 060	Carbide seat suction valve assembly	1
23	144 050 050	▪ Suction valve + nut + seal	1
20	144 050 048	▪ Ring	1
21	NC / NS	▪ Valve body	1
22	87 330	▪ Ball Ø 30 stainless steel	1
28	050 040 309	▪ O Ring PTFE	1

N S: Denotes parts are not serviceable.

Repair kit

Ind	# Reference	Description	Qty
*	144 050 225	Repair kit C225	1
5	150 319 801	▪ Spring	1
13	144 050 030	▪ Discharge valve	1
12	87 320	▪ Ball Ø 20 stainless steel	1
11	209 651	▪ Female joint clamp	1
7	209 652	▪ Male joint clamp	1
6	144 050 033	▪ Spring cartridge	1
20	144 050 048	▪ Ring	1
22	87 330	▪ Ball Ø 30 stainless steel	1
23	144 050 050	▪ Suction valve + nut + seal	1

Fluid section seal kit

144 050 303

Ind	# Reference	Description	Qty
*	144 050 313	Pack of seals	1
24	N.C. / N.S.	▪ Chevron seal, UHMWPE	7
25	N.C. / N.S.	▪ Chevron seal, PTFE	7
27	044 050 031	▪ Adjustment wedge	8
14	909 420 311	▪ O-ring, PTFE	3

* Recommended maintenance parts.

N S: Denotes parts are not serviceable.

Assembly of the joints

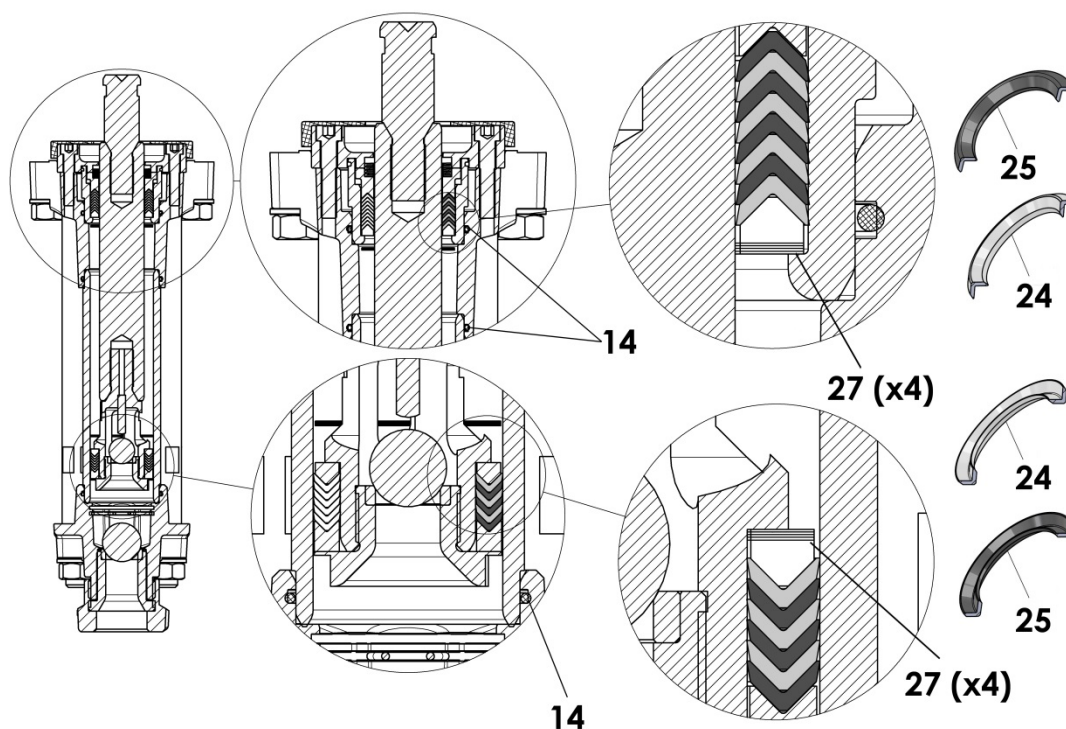

Note: It is recommended to run in the seals for 10 minutes at 6 bar / 87 psi air pressure at a rate of 6 cycles/min. before starting the pump.

Fluid section seal kit**# 144 050 304**

Ind	# Reference	Description	Qty
*	144 050 314	Pack of seals	1
26	N.C. / N.S.	▪ Chevron seal, UHMWPE	7
25	N.C. / N.S.	▪ Chevron seal, leather	7
27	044 050 031	▪ Adjustment wedge	8
14	909 420 311	▪ O-ring, PTFE	3

* Recommended maintenance parts.

N S: Denotes parts are not serviceable.

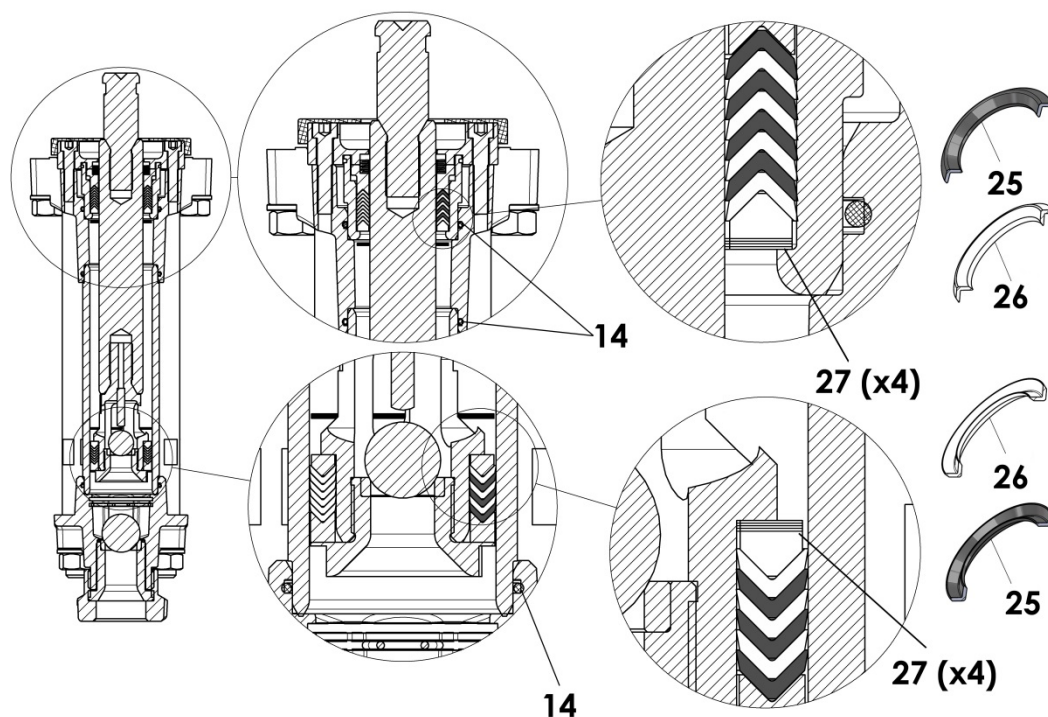
Assembly of the joints

Note: It is recommended to run in the seals for 10 minutes at 6 bar / 87 psi air pressure at a rate of 6 cycles/min. before starting the pump.

Fluid section seal kit

144 050 305

Ind	# Reference	Description	Qty
*	144 050 315	Pack of seals	1
24	N.C. / N.S.	▪ Chevron seal, UHMWPE	7
26	N.C. / N.S.	▪ Chevron seal, PTFE G	7
27	044 050 031	▪ Adjustment wedge	4
14	909 420 311	▪ O-ring, PTFE	3

* Recommended maintenance parts.

N S: Denotes parts are not serviceable.

Assembly of the joints

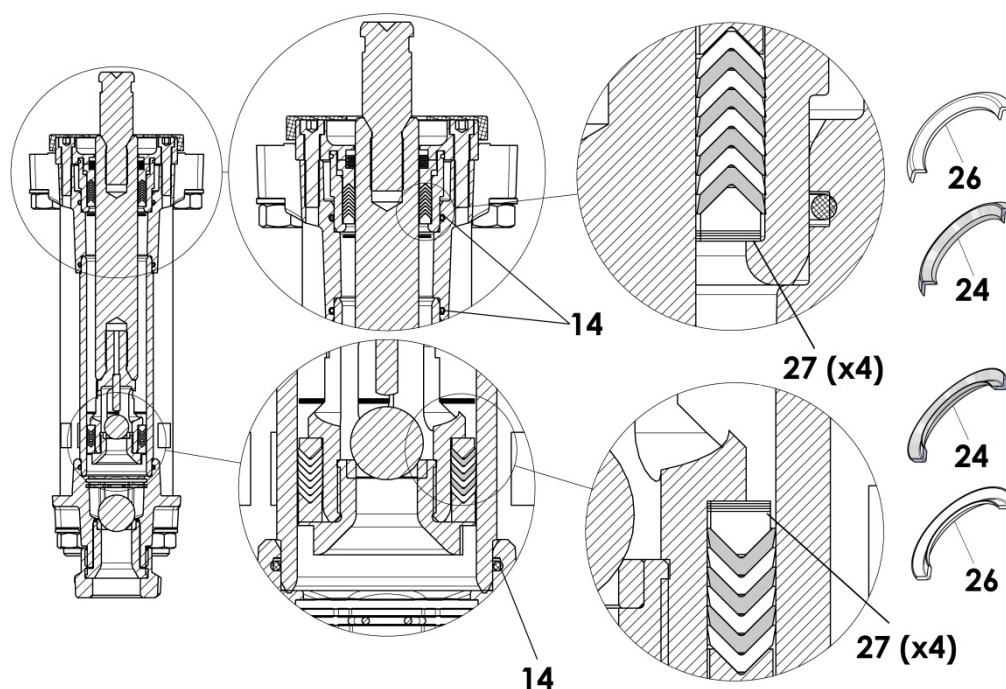

Note: It is recommended to run in the seals for 10 minutes at 6 bar / 87 psi air pressure at a rate of 6 cycles/min. before starting the pump.

19.3 Spare Parts - Product Filter 3/4", Model 500 bar / 7252 psi

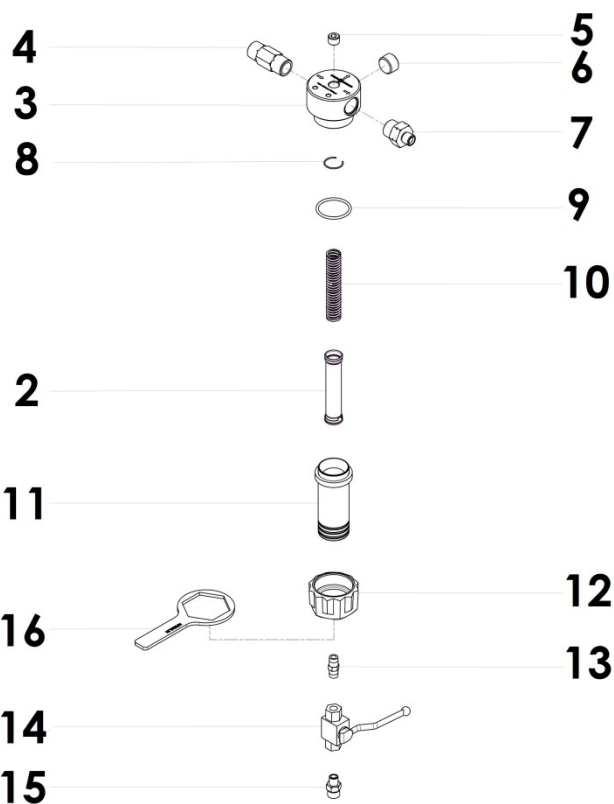
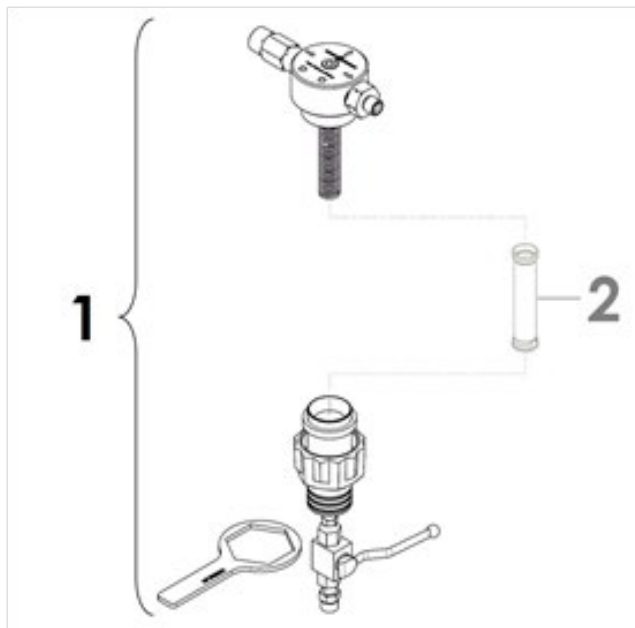

Filter equipped

Ind	# Reference	Description	Qty
1	155 581 456	Bare stainless steel filter 500 bar	1
2*	000 161 115	No. 8 screen (210 µm)	1
3	N.C. / N.S.	Socket G3 / 4 "	1
4	055 581 401	Nipple R 3/4 P.max: 500 bar	1
5	905 210 304	Cap 3/8 NPT Stainless steel	1
6	906 333 105	Chemical Nickel Gas Cap3/4 "	1
7	905 210 517	Fitting 3/4 "G x 3/8" NPSM Stainless steel	1
8	055 190 007	Stop ring	1
9*	150 040 327	Seal (the 5)	1
10	055 190 005	Stainless spring	1
11	N.C. / N.S.	Tank	1
12	055 280 002	Lock nut	1
13	N.C. / N.S.	Straight nipple MM 1/4 "- 80 bar stainless steel	1
14	601 046	Valve HP 1/4 GZ - DN06	1
15	050 102 408	Fitting MM 18x125 - 1 / 4G	1

* Recommended maintenance parts.

N S: Denotes parts are not serviceable.

Option

Ind. / Pos. 2

Ind	#References	Description	Qty
-	000 161 101	Screen n° 1 (37 µ)	1
-	000 161 102	Screen n° 2 (77 µ)	1
-	000 161 104	Screen n° 4 (99 µ)	1
-	000 161 106	Screen n° 6 (168 µ)	1
2	000 161 108	Screen n° 8 (210 µ)*	1
-	000 161 112	Screen n° 12 (280 µ)	1
-	000 161 115	Screen n° 15 (360 µ)	1
-	000 161 020	Screen n° 20 (510 µ)	1
-	000 161 030	Screen n° 30 (750 µ)	1
-	100 161 104	Set of 25 screens n° 4	1
-	100 161 106	Set of 25 screens n° 6	1
-	100 161 108	Set of 25 screens n° 8	1
-	100 161 112	Set of 25 screens n° 12	1

* Original screen mounted on the pump.

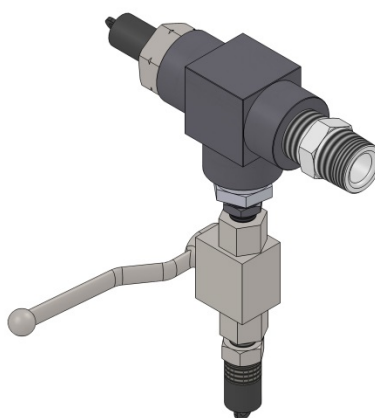

Ind. / Pos. 3

Ind	# Reference	Description	Qty
-	055 490 020	Non-return valve MF 3/4" G	1
-	151 590 012	Priming kit (without filter) for 3/8" hoses	1
-	907 414 703	Ceramic ball Ø16	1
-	907 414 705	Ceramic ball Ø30	1
-	907 414 342	Carbide ball Ø16	1
-	907 414 343	Carbide ball Ø30	1
-	909 420 311	O Ring PTFE Ø58	1
-	151 590 510	Pump bracket	1
-	151 590 511	Pump bracket for air supply	1
-	151 240 010	Bracket for rod 2"	1
-	550 011	Straight nipple MM 1/4"G stainless steel	1
-	601 046	Drain valve protected steel	1
-	601 374	Drain valve Stainless steel	1
-	149 596 250	Drain hose	1
-	921 080 303	Pin L=28mm	1
-	921 080 304	Pin L=24mm	1
-	144 050 075	Discharge valve stainless steel	1
-	144 050 055	Suction valve stainless steel	1

Accessories

Ind. / Pos. 16

Ind	# Reference	Description	Qty
16	149 030 017	Wrenching wrench	1

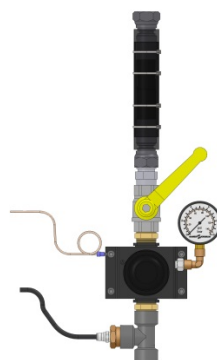

Ind. 17

Ind	# Reference	Description	Qty
17	151 590 105	Air supply	1



Ind. 18

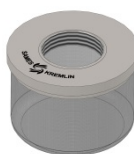

Ind. 19

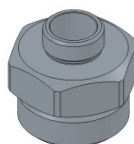

Ind. 22

Ind	# Reference	Description	Qty
18	149 597 200	Suction rod 1"1/4 L=600	1
-	149 597 210	Suction rod 2" L=600	1
22	150 104 106	Straight fitting M 1"1/4 G – M 2" G	1
-	149 597 250	Suction rod 1"1/4 L=1000	1
19	149 596 153	Strainer for suction rod (2000 μ)	1

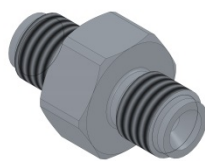

Ind. 20



Ind. 21

Ind	# Reference	Description	Qty
-	150 104 106	Straight fitting M 1"1/4G M 2 "G for rod 2".- stainless steel 250 bar / 3626 psi	1
-	144 050 052	Straight fitting MM 1"1/4G	1
20	150 104 151	Straight fitting MM 1/4" NPSM – stainless steel 500 bar / 7252 psi	1
-	150 104 152	Straight fitting MM 3/8" NPSM – stainless steel 500 bar / 7252 psi	1
-	150 104 153	Straight fitting MM 1/2" NPSM – stainless steel 500 bar / 7252 psi	1
-	905 210 516	Straight fitting M 3/8" NPSM M1/4" NPSM – stainless steel 500 bar / 7252 psi	1
-	150 104 101	Straight fitting M 1/2" NPSM M1/4" NPSM – stainless steel 500 bar / 7252 psi	1
-	150 104 102	Straight fitting M 3/4"G M 1/4" NPSM – stainless steel 500 bar / 7252 psi	1
-	150 104 103	Straight fitting M 3/4"G M 3/8" NPSM – stainless steel 500 bar / 7252 psi	1
-	150 104 104	Straight fitting M 3/4"G M 1/2" NPSM – stainless steel 500 bar / 7252 psi	1
-	150 104 105	Straight fitting M 3/8" NPSM M 1/2" JIC – stainless steel 500 bar / 7252 psi	1
21	150 104 251	T fitting 1x M 3/4"G – 2x F 3/4"G - stainless steel 500 bar / 7252 psi	1



Ind.23



Ind.27

Ind	# Reference	Description	Qty
23	151 590 700	Cart	1
-	151 590 565	Cart handle + screws	1
27	056 100 199	Mounting bracket with bracket	1

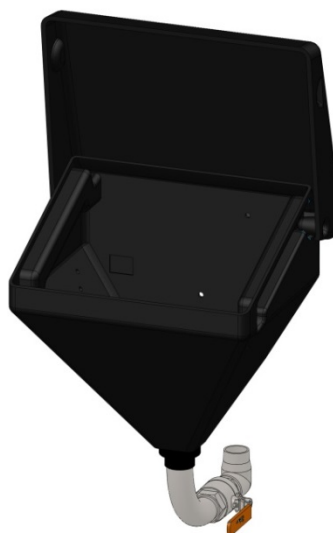

Ind.24

Ind	# Reference	Description	Qty
24	125 010 000	Hopper 20L assembly	1



Ind.25

Ind	# Reference	Description	Qty
25	156 160 040	Heater, model MAGMA 500 DI9 230V 3500W M 1/2 JIC (refer to doc 582.104.110)	1
-	156 160 050	Heater, model MAGMA 500 DI9 115V 1800W M 1/2 JIC (refer to doc 582.104.110)	1
-	156 160 060	Heater, model MAGMA 500 DI9 400V 3800W M 1/2 JIC (refer to doc 582.104.110)	1
-	156 160 010	Heater, model MAGMA 500 DI14 230V 3500W M 3/4 JIC (refer to doc 582.104.110)	1
-	156 160 020	Heater, model MAGMA 500 DI14 115V 1800W M 3/4 JIC (refer to doc 582.104.110)	1
-	156 160 030	Heater, model MAGMA 500 DI14 400V 3800W M 3/4 JIC (refer to doc 582.104.110)	1
-	156 160 070	Heater, model MAGMA 500 DI14 440V 3800W M 3/4 JIC (refer to doc 582.104.110)	1



Ind.26

Ind	# Reference	Description	Qty
-	151 590 016	Kit Sprayer	1
26	135 745 449	▪ Airless spray gun Sflow 450 bar / 6526 psi (refer to doc 582.094.110)	1
-	050 500 207	▪ Hose PA 15M 3/8" NPSM - 500 bar / 7252 psi	1
-	905 210 516	▪ Nipple MM 3/8" NPSM - 1/4 NPSM	1
-	050 500 401	▪ Hose 1/4" NPSM 1.6m 500 bar / 7252 psi	1
-	151 590 015	Fitting for 2 guns (without filter) for hoses 1/2" NPSM	1
-	050 104 251	▪ Y fitting 1x M 3/4"G 2x F3/4"G – Stainless steel 500 bar / 7252 psi	1
-	050 104 104	▪ Straight fitting M 3/4"G - M 1/2 NPSM – Stainless steel 500 bar / 7252 psi	1
-	151 590 014	Fitting for 2 guns (without filter) for hoses 3/8" NPSM	1
-	050 104 251	▪ Y fitting 1x M 3/4"G 2x F3/4"G – Stainless steel 500 bar / 7252 psi	1
-	050 104 103	▪ Straight fitting M 3/4"G - M 3/8 NPSM – Stainless steel 500 bar / 7252 psi	1
-	151 590 013	Fitting for 2 guns (without filter) for hoses 1/4" NPSM	1
-	050 104 251	▪ Y fitting 1x M 3/4"G 2x F3/4"G – Stainless steel 500 bar / 7252 psi	1
-	050 104 102	▪ Straight fitting M 3/4"G - M 1/4 NPSM – Stainless steel 500 bar / 7252 psi	1
-	129 670 405	Swivel fitting, model F 1/2 JIC - M 1/2 JIC	1
-	129 670 415	Swivel fitting, model F 1/2 JIC - M 1/4 NPSM	1
-	050 123 304	Fitting, model F 1/2 JIC - M 1/4 NPSM	1

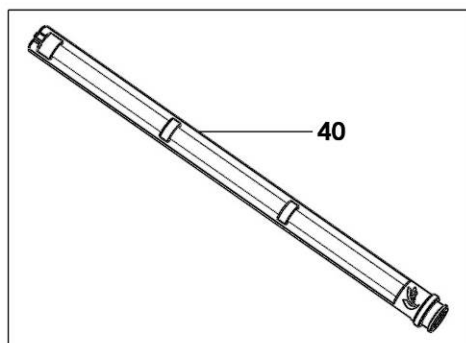
GUN FILTER (x 4)

Ind	#	Material	Mesh	Color	Tip	Qty
40	129 740 081	Stainless steel	200 mesh/ 74μ	Red	04-XX → 06-XX	1
	129 740 181	PA				1
	129 740 082	Stainless steel	150 mesh / 100μ	Blue	06-XX → 12-XX	1
	129 740 182	PA				1
	129 740 083	Stainless steel	100 mesh / 149μ	Yellow	12-XX → 18-XX	1
	129 740 183	PA				1
	129 740 084	Stainless steel	50 mesh / 300μ	White	18-XX → 100-XX	1
	129 740 184	PA				1

CHART - REVERSING TIPS

Ø orifice (pouce / ") Size	Water flow rate (L/min) at XXX bar			Handle Filter (MESH)	Pump filter Number (MESH)	Angle	30°	40°	50°	60°	70°	80°	90°	
	70	200	400			Fan width (cm) at 25 cm	12 / 16	17 / 21	22 / 24.5	25 / 29	29 / 33	33 / 37	38 / 44	
0.009 04	0.22	0.37	0.53	Red (200)	4 (140)	Number engraved on the tip		04-09 (309)	04-11 (409)	04-13 (509)				
0.011 06	0.33	0.56	0.79	Blue (150)	6 (85)		06-07 (211)	06-09 (311)	06-11 (411)	06-13 (511)	06-15 (611)			
0.013 09	0.45	0.76	1.08		6 (85)		09-07 (213)	09-09 (313)	09-11 (413)	09-13 (513)	09-15 (613)	09-17 (713)		
0.015 12	0.6	1.01	1.43		8 (70)		12-07 (215)	12-09 (315)	12-11 (415)	12-13 (515)	12-15 (615)	12-17 (715)		
0.017 14	0.72	1.22	1.72		8 (70)		14-07 (217)	14-09 (317)	14-11 (417)	14-13 (517)	14-15 (617)	14-17 (717)	14-19 (817)	
0.019 18	0.95	1.61	2.27	Yellow (100)	12 (55)		18-07 (219)	18-09 (319)	18-11 (419)	18-13 (519)	18-15 (619)	18-17 (719)	18-19 (819)	
0.021 25	1.33	2.25	3.18		12 (55)				25-11 (421)	25-13 (521)	25-15 (621)	25-17 (721)	25-19 (821)	
0.023 30	1.6	2.70	3.82		15 (45)				30-11 (423)	30-13 (523)	30-15 (623)	30-17 (723)	30-19 (823)	
0.025 40	2.17 5	3.68	5.20		15 (45)				40-11 (425)	40-13 (525)	40-15 (625)	40-17 (725)	40-19 (825)	
0.029 45	2.38	4.02	5.69	White (50)	20 (30)			45-09 (329)	45-11 (429)	45-13 (529)	45-15 (629)	45-17 (729)	45-19 (829)	
0.033 68	3.78	6.39	9.04		30 (20)				68-11 (433)	68-13 (533)	68-15 (633)	68-17 (733)	68-19 (833)	
0.036 100	5.6	9.47	13.39		30 (20)					100-13 (539)	100-15 (639)	100-17 (739)	100-19 (839)	

To obtain tip part number, replace the crosses by the engraved tip number preceded by 000.40X.XXX
 Example : use part number 000 402 513 to obtain tip 25.13

Hoses codification

HOSES CODIFICATION

050	XXX	X	X	X
Working pressure				Hose lenght
350B : 350				1: 0.5 m / 19.68"
500B : 500				2: 1 m / 39.37"
				3: 1.6 m / 63"
				4: 3 m / 118.1"
				5: 7.5 m / 295.3"
				6: 10 m / 393.7"
				7: 15 m / 550.55"
				8: 30 m / 1181.1"
		Diameter		
		Ø6.35 - 1/4" : 1		
		Ø 9.5 - 3/8 : 2		
		Ø12.7 - 1/2 : 3		
		Hose material		
		Polyamid : 0		
		PTFE : 5		

Hoses 350 bar / 5076 psi

Maximum working pressure (bar) / (psi)	350 / 5076					
Material	PA			PTFE		
Fitting A and B (Lock nut)	1/4 NPSM	3/8 NPSM	1/2 NPSM	1/4 NPSM	3/8 NPSM	1/2 NPSM
Ø inside	Ø6.35 / 0.24"	Ø 9.5 / 0.37"	Ø12.7 / 0.5"	Ø6.35 / 0.24"	Ø 9.5 / 0.37"	Ø12.7 / 0.5"
0.5 m / 19.68"	050 350 101	050 350 201	050 350 301	050 350 151	050 350 251	050 350 351
1 m / 39.37"	050 350 102	050 350 202	050 350 302	050 350 152	050 350 252	050 350 352
1.6 m / 63"	050 350 103	050 350 203	050 350 303	050 350 153	050 350 253	050 350 353
3 m / 118.1"	050 350 104	050 350 204	050 350 304	050 350 154	050 350 254	050 350 354
7.5 m / 295.3"	050 350 105	050 350 205	050 350 305	050 350 155	050 350 255	050 350 355
10 m / 393.7"	050 350 106	050 350 206	050 350 306	050 350 156	050 350 256	050 350 356
15 m / 550.55"	050 350 107	050 350 207*	050 350 307	050 350 157	050 350 257	050 350 357
30 m / 1181.1"	050 350 108	050 350 208	050 350 308	050 350 158	050 350 258	050 350 358

* In stock regularly

Hoses 500 bar / 7252 psi

Maximum working pressure (bar) / (psi)	00 / 7252					
Material	PA			PTFE		
Fitting A and B (Lock nut)	1/4 NPSM	3/8 NPSM	1/2 NPSM	1/4 NPSM	3/8 NPSM	1/2 NPSM
Ø inside	Ø6.35 / 0.24"	Ø 9.5 / 0.37"	Ø12.7 / 0.5"	Ø6.35 / 0.24"	Ø 9.5 / 0.37"	Ø12.7 / 0.5"
0.5 m / 19.68"	050 500 101	050 500 201	050 500 301	050 500 151	050 500 251	050 500 351
1 m / 39.37"	050 500 102	050 500 202	050 500 302	050 500 152	050 500 252	050 500 352
1.6 m / 63"	050 500 103	050 500 203	050 500 303	050 500 153	050 500 253	050 500 353
3 m / 118.1"	050 500 104	050 500 204	050 500 304	050 500 154	050 500 254	050 500 354
7.5 m / 295.3"	050 500 105	050 500 205	050 500 305	050 500 155	050 500 255	050 500 355
10 m / 393.7"	050 500 106	050 500 206	050 500 306	050 500 156	050 500 256	050 500 356
15 m / 550.55"	050 500 107	050 500 207*	050 500 307	050 500 157	050 500 257	050 500 357
30 m / 1181.1"	050 500 108	050 500 208	050 500 308	050 500 158	050 500 258	050 500 358

* In stock regularly