



## User manual

### Nanogun Airspray and GNM 6080 versions LR - HR - MR

SAMES KREMLIN SAS - 13, Chemin de Malacher - 38240 MEYLAN - FRANCE  
Tel. 33 (0)4 76 41 60 60 - [www.sames-kremlin.com](http://www.sames-kremlin.com)

This document may not be passed on or reproduced in any form whatsoever nor may its contents be used or disclosed without express written permission from SAMES KREMLIN.

The descriptions and characteristics contained in this document are subject to change without notice.

© SAMES KREMLIN 2014



**WARNING :** SAMES KREMLIN SAS is registered with the Ministry of Labour as a training institution.  
Throughout the year, our company offers training courses in the operation and maintenance of your equipment.  
A catalogue is available on request. Choose from a wide range of courses to acquire the skills or knowledge that is required to match your production requirements and objectives.  
Our training courses can be delivered at your site or in the training centre at our Meylan head office.

Training Department:  
Tel.: 33 (0)4 76 41 60 04  
E-mail : [formation-client@sames-kremlin.com](mailto:formation-client@sames-kremlin.com)

SAMES KREMLIN **SAS** user manuals are written in French and translated into English, German, Spanish, Italian and Portuguese.

The French version is deemed the official text and SAMES KREMLIN will not be liable for the translations into other language

# Nanogun Airspray and GNM 6080 versions LR - HR - MR

1. Product identification	6
1.1. Identifying the version	6
1.1.1. By the barrel	6
1.1.2. On the lower part of the gun handle	6
1.2. GNM 6080 control module	7
2. Health and Safety Instructions	8
2.1. Regulations	8
2.2. Installation rules	8
2.3. Operating rules	9
2.4. Maintenance rules	10
2.4.1. Products used	11
3. Description of spray gun and GNM 6080 control module	12
3.1. Functions available on spray gun	12
3.2. GNM 6080 Control module	13
4. Technical characteristics	15
4.1. General spray gun characteristics	15
4.2. GNM 6080 Characteristics	16
4.3. Compressed air characteristics	16
5. Operation	17
6. Special tools	18
6.1. Using the multipurpose spanner	20
7. Installation	21
7.1. With piston pump for all versions	21
7.2. With diaphragm pump for all versions	22
7.3. With a pressure tank for all versions	23
8. Operation	24
8.1. Paint Recommendations	24
8.1.1. Viscosity	24
8.1.2. Resistivity	24
8.2. Settings of the spraying parameters	25
9. Misuse of the Apparatus	28
10. Maintenance	29
10.1. Preventive maintenance table	29
10.2. Electropneumatic coupling	30
10.3. Paint Hoses	31
10.3.1. Paint hose - QD version (HR)	31
10.3.2. Paint hose LR-MR	32
10.4. Spray head assembly	33

10.5. Barrel	34
10.6. Paint needle	35
10.7. Switch	35
10.8. Trigger	36
10.9. Air valve	36
10.9.1. Repairing the air valve	37
10.10. Fixing hook	38
10.11. High voltage cascade	39
10.12. Barrel	40
10.13. Handle	41
10.14. Electric diagrams	42
10.14.1. Connection cable GNM 6080 / Nanogun Airspray.	42
10.14.2. GNM 6080 trigger cable	42
11. Cleaning	43
11.1. Cleaning the product circuit	43
11.2. Cleaning the spray gun	43
11.3. Waste disposal	43
11.4. Demolition and Recycling	44
11.4.1. Nanogun Airspray	44
11.4.2. GNM 6080	46
12. Troubleshooting Guide	47
13. Spare Parts	49
13.1. Nanogun Airspray spray guns low pressure for high resistivity (HR) solvent paint $\rho > 10M\Omega.cm$	49
13.2. Nanogun Airspray, low Pressure spray guns for solvent paint $0.5 M\Omega.cm < \rho < 500 M\Omega.cm$	51
13.3. Nanogun Airspray, low Pressure spray guns for solvent paint $2 M\Omega.cm < \rho < 500 M\Omega.cm$	52
13.4. Nanogun Airspray spray guns, all versions	53
13.5. Barrel assembly	55
13.6. Air valve and Nut air valve	56
13.7. Air cap ring	57
13.8. Nozzle support	57
13.9. Round Nozzle assemblies - LP Models	58
13.10. Needle assembly	59
13.11. Electropneumatic coupling sets	59
13.12. Paint hoses	60
13.12.1. For Nanogun Airspray Low Pressure and High Resistivity spray guns	60
13.12.2. For Nanogun Airspray Low Pressure and Low Resistivity spray guns	60
13.12.3. For Nanogun Airspray Low Pressure and middle Resistivity spray guns	61
13.13. Nanogun Airspray seal set	62
13.14. GNM 6080 Control module	63

13.15. Options for Nanogun Airspray Low Pressure spray guns	64
13.15.1. Flat Spray Air Caps	64
13.15.2. In-line product filters	64
13.16. Appendices	65
13.16.1. Protective hose covering	65
13.16.2. Protective case for spray gun	65
13.16.3. Warning notice	65
13.16.4. Safety valve	65
14. The different versions-	66
14.1. Equipments	66
14.2. Configuration	68

# 1. Product identification

The various markings on **Nanogun Airspray** spray guns can be used to identify whether low pressure (LP) configuration is being used.

## 1.1. Identifying the version

### 1.1.1. By the barrel

All **Nanogun Airspray** range products carry the same markings on the barrel.

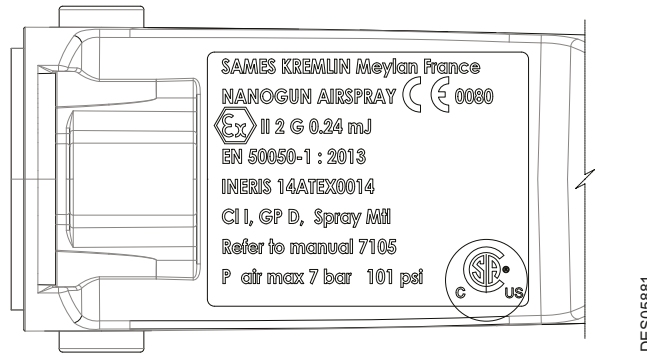

### 1.1.2. On the lower part of the gun handle



This marking groups together all spray gun configurations operating at the same product pressure under the same number.

Marking no.	Product pressure	Nanogun Airspray models
910015741	7 bar	JR06-LR; JR06-MR; JR06-HR JR08-LR; JR08-MR; JR08-HR JR12-LR; JR12-MR; JR12-HR JP-LR; JP-MR; JP-HR

## 1.2. GNM 6080 control module

The **GNM 6080** control module should not be installed in an ATEX zone (potentially explosive atmosphere). It is defined as “associated material” for the purposes of the ATEX directive.

### Markings

#### CE Marking



#### CSA Marking



Example: \* 2014: Year of manufacturing

26: Week number

123: Nth control module made in the week 26.



**WARNING :** Equipment Nanogun Airspray is in accordance with the functional safety standard (Standard EN13849, level SIL 1), the preservation of this level of safety imposes a periodic control of the equipment, in minima every 5 years or 15000 hours of functioning (to the first one 2 reached). This control concerns each of the electric and electronic components as well as on it or the very specific programs, you have to get in contact with your subsidiary, distributor or usual representative of SAMES KREMLIN who will indicate you the steps to be carry out.

## 2. Health and Safety Instructions



**WARNING :** This equipment may become a safety hazard if it is not operated, disassembled and reassembled in accordance with the instructions given in this manual and in any European Standard or national safety regulations in force.

The warning notice summarizing the safety rules (procedures and precautions) laid out in this instruction manual must be clearly displayed in the area of the spraying workstation.



**WARNING :** Equipment performance is only guaranteed if original spare parts distributed by SAMES KREMLIN are used.

### 2.1. Regulations

The **Nanogun Airspray** spray gun must always be used according to the requirements stipulated in the standards and regulations in force concerning painting and clear coat methods (see Standards and Directives EN 50.053 part 1 ISO 12100, EN 1953 and 99/92/CE).

In **Canada**, the installation has to be in compliance with the code " electrical C22.1 Canadian code, part I, standard safety for electrical installations ".

In the **USA**, the installation has to be in compliance with the code " NFPA 70: National Electrical Code ".

**CAUTION:** Model **Nanogun Airspray** spray applicator is suitable for use in **CLASS I, DIVISION 1, GROUP D HAZARDOUS LOCATIONS** when connected to model **GNM 6080** power supply unit.

The Pollution Degree Rating of the **Nanogun Airspray** is "Pollution Degree 2" following IEC-664-1 standard **Pollution Degree 2:** Normally only non-conductive pollution occurs. Temporary conductivity caused by condensation is to be expected.



**WARNING :** Before any use of the **Nanogun Airspray** spray gun, check that all operators

- have previously been trained by the company SAMES KREMLIN, or by their distributors registered by them for this purpose.
- have read and understood the user manual and all rules for installation and operation, as listed below.

**It is the responsibility of the operator's workshop manager to ensure these two points and it is also his responsibility to make sure that all operators have read and understood the user manuals for any peripheral electrical equipment present in the spraying area.**

### 2.2. Installation rules

- The manual projection electrostatic material must be used only in projection area according to the standard EN 12215 or in equivalent conditions of ventilation.
- The control module must not be installed **where there is a potential explosion risk**.
- It must be impossible to start up the control module before the spray booth air extraction system is in operation.
- The control module must be properly connected to the ground terminal on the device.
- The paint (or solvent) pump and tank must be connected to a ground terminal on the device.



- All metal parts of the apparatus (paint pumps, containers, stools, turntables, etc.) less than three metres from the spray gun must be grounded.
- The spraying area must be kept clean and clear of any unnecessary items.
- The floor on which the operator works must be dissipator (bare concrete or metal duck-board). Never use an insulating floor covering. In area potentially explosive, the assemblies of grounds have to be dissipators according to the standard EN 61340-4-1.
- Naked flames, glowing objects or a devices likely to produce sparks (other than the atomizer) must not be used inside the booth.  
The storage of inflammable products, or vessels that have contained them, close to the booth or in front of the doors is prohibited.
- Pots and tubs containing paint or solvent must always be closed after use.
- The paint supply pump used must have a maximum ratio of 1:1 and the pump air supply must be fitted with a safety valve limiting the pressure to 6.5 bar maximum.
- **In the explosive area**, it is forbidden to use any non-certified electrical or non-electrical equipment such as electronic extension leads, multiple socket adapters, switches, etc.

### 2.3. Operating rules

- The ventilation system must be checked on a daily basis to ensure it is working properly.
- Performance checks must be carried out on the extraction control system once a week.
- Before starting to spray, check that the nozzle/tip and air cap are fitted to the gun and that the air cap ring is fully tightened.
- All metal parts of the booth and parts to be painted must be correctly grounded. Ground resistance must be less than or equal to 1M $\Omega$  (measurement voltage 500 V). This resistance value must be regularly checked.
- The operator must wear dissipator shoes according Standard EN 61340-4-3 and hold the **Nanogun Airspray** spray gun bare-handed or with gloves that are either dissipators or specially adapted to allow direct contact between the handle and the operator's hand. Shoes intended to be worn by the operator have to be in accordance with the standard ISO 20344. The measured insulating resistance does not have to exceed 100M $\Omega$ .
- Protective clothings intended to be worn, including gloves, have to be in accordance with the standard EN 1149-5. The measured insulating resistance does not have to exceed 100M $\Omega$ .
- The operator must also wear ear defenders when using Nanogun Airspray spray guns ([see § 4 page 15](#)).
- Ensure that anyone who enters the spraying area is wearing dissipator shoes or is otherwise grounded.
- Never throw or drop deliberately the electrostatic spray gun. Dropping the gun could damage the high voltage generator. After a drop, it is advised to verify the functioning of the pistol out off zone before its re-use.
- Never point the spray gun towards a person.
- Check the spray gun at least 1 time a week.
- Never use the apparatus in the following situations:
  - 1 If you notice an air leak from the spray gun when the trigger is released.
  - 2 If the spray gun electrical connector catch is not held securely in place with two safety screws.
  - 3 If the spray gun barrel, handle show signs of an impact that may have deteriorated the air-tightness of internal components.
- The manual electrostatic projection equipment must be exploited only if it is in a perfect state. A damaged equipment must be immediately removed from the installation and must be repaired.  
The worn out components must be immediately replaced.
- Follow the precautions specified for the paints and solvents used (e.g. wear a mask etc.).
- Close and dump the air and paint supply before leaving the device shut down for an extended period.

- Check the paint hose is in good condition before starting to operate the device.
- The electropneumatic coupling, held in place by two safety screws **MUST NEVER BE DISCONNECTED IN A POTENTIALLY EXPLOSIVE ATMOSPHERE.**
- If any of the following elements are damaged, all operations with the device must be stopped: barrel, handle, electropneumatic coupling, air cap or air cap ring.

#### 2.4. Maintenance rules

- Service regularly and repair the electrostatic spraying equipment in accordance with the instructions in this user manual.
- Metal containers only should be used to hold cleaning liquids and they must have a reliable ground connection.
- Before any maintenance or servicing operation:
  - 1 Disconnect the control module from the power supply.
  - 2 Check that the air and paint circuits are not pressurized.
  - 3 Dump the paint Circuit
  - 4 All the energy sources must be consigned.
- Cleaning operations must be carried out either in authorised areas equipped with a mechanical ventilation system, or using cleaning liquids with a flash point at least 15 °C higher than the ambient temperature.
- Use non flammable cleaning products preferably.
- Do not reconnect the electrical power supply until the air cap and nozzle/tip have been correctly reassembled on the spray gun.
- Never soak or immerse the spray gun in solvent. If required, the spray gun may be cleaned by wiping with a cloth soaked in solvent and then immediately dried to prevent the solvent entering the spray gun.



**WARNING :** Never spray solvent whilst the control module is live and/or the switch located on the back of the gun is in position «I».



**WARNING :** The cut of the compressed air supply does not prohibit the release of the high voltage when the trigger is activate.

- Operators must be trained by SAMES KREMLIN, or by their distributors registered by them for this purpose, to perform **Nanogun Airspray** spray gun maintenance operations.



**WARNING :** It is forbidden to use oil-based solvent and products containing such solvents if aluminium or zinc are present. Users who do not follow these instructions are exposed to explosion risks.

#### 2.4.1. Products used

Given the wide range of products used, and that fact that it is impossible to produce an inventory of these products, SAMES KREMLIN cannot be held liable for:

- incompatibility of product material used when in contact with materials listed below:
  - Stainless steel
  - Fluoroethylenepropylene (FEP)
  - Polyamide-imide (PAI)
  - Polyoxymethylene (POM)
  - Tungsten carbide and Tungsten
  - PTFE elastomer
  - Polypropylene
  - IXEF
  - Glass fibre
  - Ceramics
  - Aluminium
  - Titanium
  - PEEK
  - PEHD andPEBD
  - Chemically inert rubber
- Risks related to the use of these products for personnel and the environment include.
- Wear, incorrect adjustments or malfunction of equipment or machines, together with the non-quality of the application caused by the use of these products.

### 3. Description of spray gun and GNM 6080 control module

**Nanogun Airspray** spray guns are designed to spray paint or clear coat whose resistivity is greater than 0.5 MΩ.cm only.

The configurations **LR** can moreover spray hydrodiluable paints or clear coats when they are equipped with the suitable produced means of supply. The use of any other type of paint is excluded.

**Nanogun Airspray** spray guns are to be connected to the **GNM 6080** control module.

The models in the **Nanogun Airspray** range can be differentiated by their air cap, air cap ring, the base support and the paint hose.

	Characteristics
<b>Nanogun Airspray JR06</b>	Super Vortex Round Spray - Low Pressure - Dia: 6 mm
<b>Nanogun Airspray JR08</b>	Super Vortex Round Spray - Low Pressure - Dia: 8 mm
<b>Nanogun Airspray JR12</b>	Super Vortex Round Spray - Low Pressure - Dia: 12 mm
<b>Nanogun Airspray JP</b>	Flat Spray - Low Pressure - Dia: 12 mm

#### 3.1. Functions available on spray gun



- The switch (Item1) allows to start or to cut the high voltage.  
When this switch is on the position " I ", an action on the trigger starts up the high voltage.  
When this switch is on the position " 0 ", an action on the trigger does not start the high voltage.
- The notched button on the back of the gun (Item 2) allows to regulate the product flow.
- The side notched button (Item 3) allows to regulate the dimension of the spray.

### 3.2. GNM 6080 Control module

The GNM 6080 control module allows the display of the parameters of use as well as their adjustments.

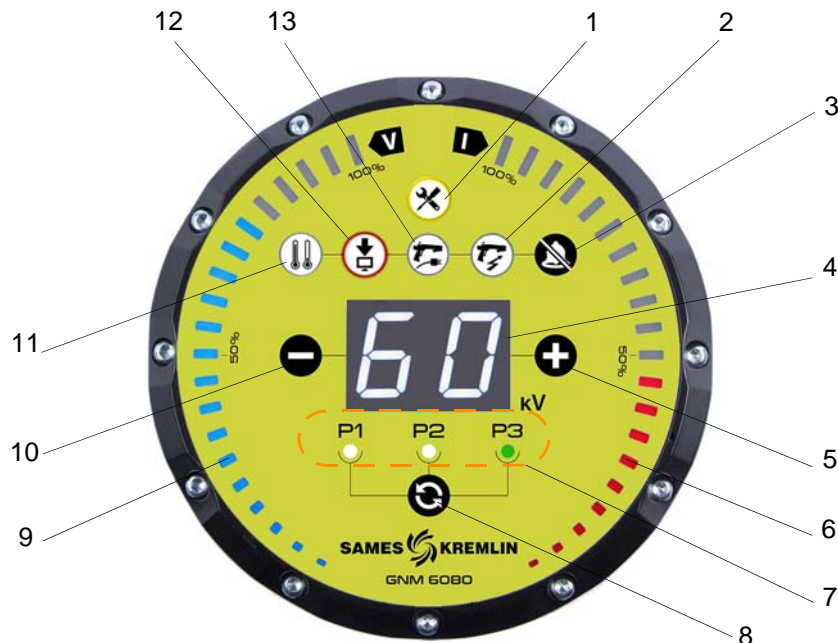

Front face of the GNM 6080 control module

1	Maintenance indicator light
2	Indicator light of high voltage fault
3	Reset of faults
4	Display of setpoint of high voltage
5	Increase of the setpoint voltage
6	Bargraph of the current consumption
7	Indicator lights of active preset memory
8	Selection of the active memory
9	Bargraph of the voltage
10	Decrease of the setpoint voltage
11	Indicator light of temperature fault
12	Indicator light of control module fault
13	Indicator light of low voltage cable



**Temperature fault** : The temperature fault forces the indicator lights (Item 11 and 12). As soon as the temperature decrease under the minimum, the temperature indicator light (Item 11) goes out and the operator can delete the fault by pressing on the button «Reset of faults» (Item 3).



**Control module fault**: this fault collects all the internal faults of the control module. If this fault can not be resetted, the problem requires the intervention of the repair department, contact SAMES KREMLIN.



**Low voltage connection fault:** the control module does not detect or any more the presence of the gun. Switch off the main power supply, check the connection between the control module and the gun.



**High voltage faults:** faults specific to the operation of the gun related to the high voltage:

- Start up of the control module with the engaged trigger.
- Peak of an important over-current during the high voltage.
- Bad functioning of the high voltage unit.



**Maintenance indicator light:** This indicator light ignites (orange) from 800000 operations of the trigger or at the 1000 hours of functioning of the gun ([see § 10.1 page 29](#)). The ignition of this light indicates that the maintenance of the gun must be carried out. No specific maintenance on the GNM 6080.  
The control module can manage up to 20 different guns.



Side face of the GNM 6080 control module

12	Plug for gun cable
13	Plug for external cabling
14	Switch ON / OFF
15	Main power supply
16	Ground connection
17	Diaphragm of pressure balancing
18	Diagnosis plug (type mini USB)

## 4. Technical characteristics

### 4.1. General spray gun characteristics

	JR06	JR08	JR12	JP
Spray type	Round Super Vortex	Round Super Vortex	Round Super Vortex	Flat spray
Air cap fitted as standard	JR06	JR08	JR12	P15
Max. paint intake pressure	7 bar	7 bar	7 bar	7 bar
Compressed-air intake pressure	6 bar $\pm$ 1 bar			
Mini/ maxi ambient temperature	0°C - 40°C			
Max. paint flow rate (paint viscosity 25s when measured with AFNOR Cup 4) in cm <sup>3</sup> /min	650	650	750	750
Spray width, 25 cm away	19 cm	20 cm	21 cm	37 cm
Air flow rate Nm <sup>3</sup> /h	6.6 - 16.8	7.8 - 16.8	9.4 - 22.5	10,3 - 25,2
Sound pressure (*)	93.8 dB(A)	93.8 dB(A)	93.8 dB(A)	98.6 dB(A)
Recommended paint viscosity (measured with AFNOR Cup 4)	14 to 50 s			
Dimensions	273 x 220 x 52			
Weight without hoses or cables	570 g			
Output voltage	Max. 60 kV [+0 kV; -1,5 kV] (adjustable on GNM 6080)			
Output current	80 $\mu$ A max.			
Short-circuit output current	< 20 $\mu$ A			
HV cascade input voltage	45 V AC max.			
HV cascade input current	300 mA max.			
Air coupling	1/4 NPS - F			
Paint fitting	1/2 JIC - M			
Paint resistivity $\rho$	10 M $\Omega$ .cm < $\rho$ < 500 M $\Omega$ .cm QD Version (high resistivity) 0.5 M $\Omega$ .cm < $\rho$ < 500 M $\Omega$ .cm LR Version (low resistivity) 2 M $\Omega$ .cm < $\rho$ < 500 M $\Omega$ .cm LR Version (middle resistivity)			
Electrical functions available on the gun	High voltage ON / OFF switch			
Electrical / pneumatic connector	The electropneumatic coupling, held in place by two safety screws <b>MUST NEVER BE DISCONNECTED IN A POTENTIALLY EXPLOSIVE ATMOSPHERE.</b>			
Altitude	2000 m maxi.			
Maximum relative humidity for temperatures up to 80% decreasing linearly to 50% relative humidity at 40°C.	Maximum 80% relative humidity, non-condensing			
Surface temperature	T6			
Index of protection	IP 20			
<b>Transportation / Storage</b>				
Time of storage	Maxi. 2ans			
Temperature of mini / maxi storage	-10°C + 45°C			
Humidity	95% without condensation			
Mini pressure	750 mBar			
Exposure to the UV radiations	Stored shielded from the light			
Exposure to the ionizing radiations	No admitted			

(\*) The weighted equivalent continuous sound pressure level is between 93.8 et 98.6dB(A), depending on spray gun version.

#### Measurement conditions:

The apparatus was operated to maximum capacity and the measurements taken in the manual paint test booth (sealed booth with glass panels) located in the SAMES KREMLIN site in Meylan, France.

**Measurement method:**

The weighted equivalent sound pressure level (93.8 et 98.6 dBA) is an LEQ value measured during observation periods over at least 30 seconds.

**4.2. GNM 6080 Characteristics**

Installation category II (according to EN 61010-1).

<b>General</b>	
Weight	1.7 kg
Dimensions	Diameter: 168 mm
	Height: 91 mm
Operating temperature	0-40°C
<b>GNM 6080 Input</b>	
Voltage	88 - 264 V AC
Frequency	50 - 60 Hz
Max. current	0,25 A
Max. power	25 V.A
<b>GNM 6080 output</b>	
Voltage	40 V rms
Current	200 mA rms

**4.3. Compressed air characteristics**

Required characteristics for compressed-air supply according to standard NF ISO 8573-1

<b>Characteristics</b>	<b>Value</b>
Maximum dew point at 6 bar (87 psi)	Class 4, i.e. + 3 °C (37° F)
Maximum particle size of solid contaminants	Class 3, i.e. 5 µm
Maximum oil concentration	Class 1, i.e. + 0.01mg/m <sub>0</sub> <sup>3</sup> *
Maximum concentration of solid contaminants	5 mg/m <sub>0</sub> <sup>3</sup> *

(\*): Values are given for a temperature of 20 ° C (68 °F) at 1013 mbar atmospheric pressure.



## 5. Operation

Pressing the trigger controls non-simultaneous opening of the air valve then engaging of high voltage and then the paint needle. The high voltage pilot can be disabled by using the switch on the gun.

**Nanogun Airspray** spray guns are fitted with a magnetic sensor which detects the position of the trigger. This sensor allows to supply the high-voltage as soon as the air valve of air moves back of a value between 1 and 1,8 mm:

- The button at the rear of the spray gun allows to adjust the paint flow.
  - Selector fully turned to the left: max. spray flow.
  - Selector fully turned to the right: reduced paint flow.
  
- The side button allows to adjust the spray.
  - Tighten screw: reduced impact.
  - Loosen screw: wide impact.

## 6. Special tools

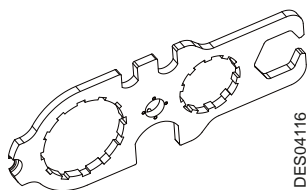

Part number	Description	Qty	Unit of sale
900010674	Multipurpose spanner	1	1

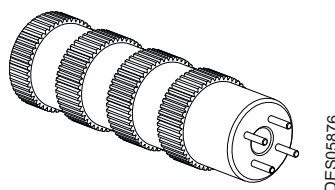

Part number	Description	Qty	Unit of sale
900010973	Disassembly/Reassembly tool for flat nozzle	option	1

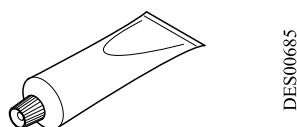

Part number	Description	Qty	Unit of sale
H1GMIN017	White vaseline (100ml)	1	1
H1GSYN037	Dielectric lubricant for high voltage cascade and needle duct (100 g)	1	1

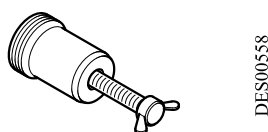

Part number	Description	Qty	Unit of sale
1402015	Flat spray diffuser removal tool	1	1
443678	JR06/JR08/JR12 diffuser removal tool	option	1

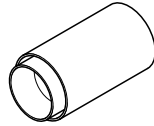

DES00559

Part number	Description	Qty	Unit of sale
444239	JR06 diffuser reassembly and alignment tool	1	1
003008	JR08 diffuser reassembly and alignment tool	1	1
003009	JR 12 diffuser reassembly and alignment tool	1	1



Part number	Description	Qty	Unit of sale
240000301	Seal extractor tool	1	1



Part number	Description	Qty	Unit of sale
129400923	Air cap cleaning brush	1	10

**Additional tools and accessories required:**

The tools listed below should be available for product installation and maintenance operations.

- Flathead screwdriver (2.5x75; 4x100, 5.5x100)
- Phillip's screwdriver (0x75; 2x125)
- Allen keys (3 - 6 mm)
- Torque wrench 1 to 5 Nm (R.304DA Facom) (SAMÉS KREMLIN P/N: 240000095)
- Open-ended spanners (5 - 5.5 - 15 - 17 - 18 - 21 - 24 - 27 mm)
- Socket wrench (socket diameters 4)
- Flat nose pliers
- Cutting pliers

## 6.1. Using the multipurpose spanner

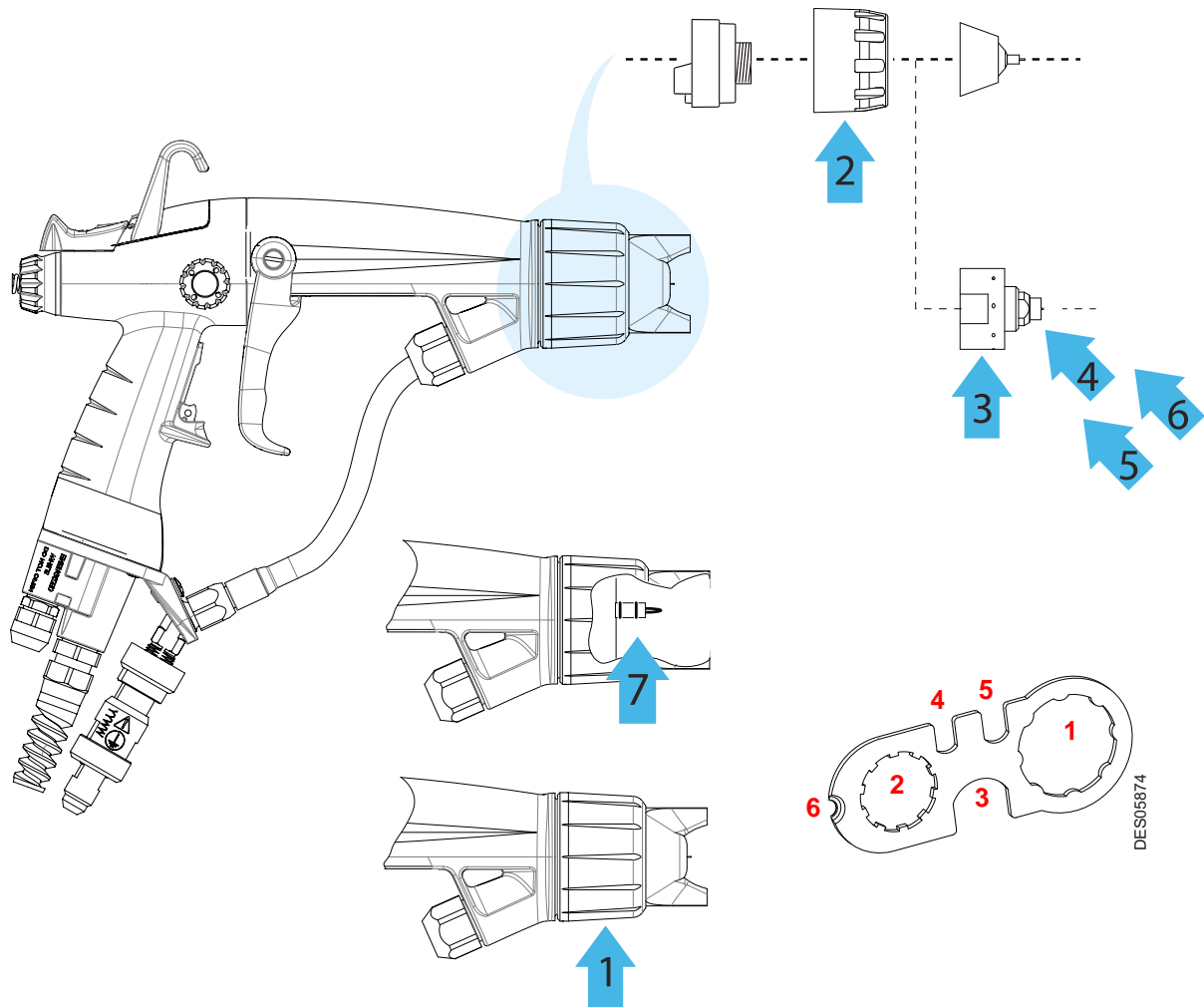

- 1 : Tighten the air cap ring.
- 2 : Tighten the ring of the nozzle support.
- 3 : Tighten the fitted low pressure nozzle assembly (round spray).
- 4 : Tighten the injector (Dia.: 6 and 8 mm) onto the air cap (round spray).
- 5 : Tighten the injector (Dia 12 mm) onto the air cap (round spray).
- 6 : Remove the seal cartridge from the barrel.

## 7. Installation



**WARNING :** Before any work, please refer to the installation rules ([see § 2.2 page 8](#)).

### 7.1. With piston pump for all versions

1	General air supply
2	Air filter
3	Main air valve
4	Pump air shut-off valve
5	Air pressure regulator
6	Spraying air filter/regulator
7	Spraying air valve
8	<b>GNM 6080</b> control module
9	Spray gun air supply hose
10	<b>Nanogun Airspray</b> Spray Gun
11	Low voltage power supply cable
12	Pump (complies with ATEX Directive)
13	Dump valve
14	Product filter
15	Product supply hose
16	Mains power cable (220V + ground) or (115V + ground)
17	Warning sign
18	Potentially explosive atmosphere
19	Area with no risk of explosion

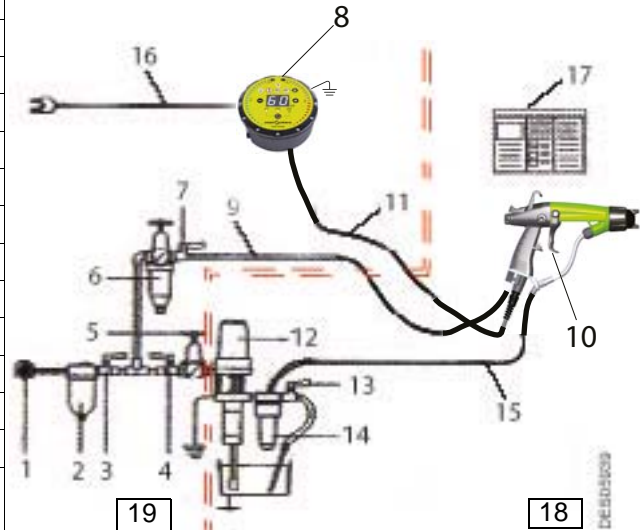

The paint supply must be installed in a well-ventilated area.

The paint container and pump must always be electrically grounded.

The dump hose must be submerged in the paint.



**WARNING :** The paint supply pump:

- must have a maximum ratio of 1:1.
- and the pump air supply must be fitted with a safety valve limiting pressure to 6.5 bar max.

## 7.2. With diaphragm pump for all versions

1	Part to be painted
2	<b>Nanogun Airspray</b> Spray Gun
3	Single-phase mains, 220 V, 50 Hz + ground or 115 V+ ground
4	Air pressure regulator 0-6 bar - 50 m <sub>0</sub> <sup>3</sup> /h (for adjusting the spraying air)
5	Compressed air network
6	Stop cocks
7	Oil-removing filter
9	Air pressure regulator 0-6 bar - 5 m <sub>0</sub> <sup>3</sup> /h For adjusting the regulator control pressure (paint flow rate setting)
10	Air pressure regulator 0-6 bar - 20 m <sub>0</sub> <sup>3</sup> /h (for adjusting the pump air supply)
12	Potentially explosive atmosphere
13	Area with no risk of explosion
14	Paint flow rate regulator
15	Diaphragm pump (complies with ATEX Directive)
16	Strainer
17	Paint container

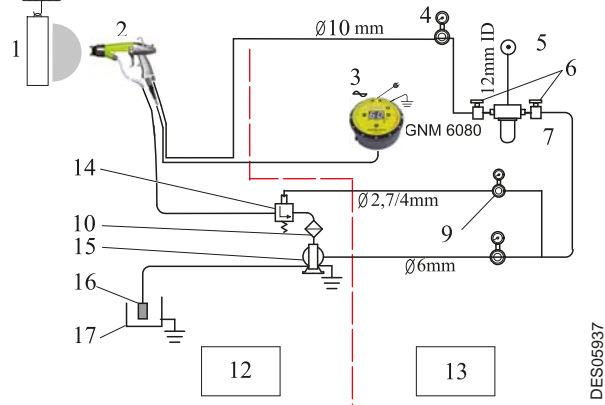

Note: m<sub>0</sub><sup>3</sup>/h volume at 1013 mbar atmospheric pressure and a temperature of 20°C (68°F).

It is recommended to fit the diaphragm pump with a valve on the return line to the paint container to prime the pump and stir the paint.



**WARNING** : For the safety of the painter, the paint container, the diaphragm pump, and the paint filter, if it is metal, must be electrically grounded.

### 7.3. With a pressure tank for all versions

1	Part to be painted
2	<b>Nanogun Airspray</b> Spray Gun
3	Single-phase mains, 220 V, 50 Hz + ground or 115 V + ground
4	Air pressure regulator 0-6 bar - 50 m <sup>3</sup> /h (for adjusting the spraying air)
5	Compressed air network
6	Stop cocks
7	Oil-removing filter
9	Air pressure regulator 0-6 bar - 5 m <sup>3</sup> /h For adjusting the regulator control pressure (paint flow rate setting)
10	Filter
11	Pressure tank (complies with ATEX Directive)
12	Potentially explosive atmosphere
13	Area with no risk of explosion

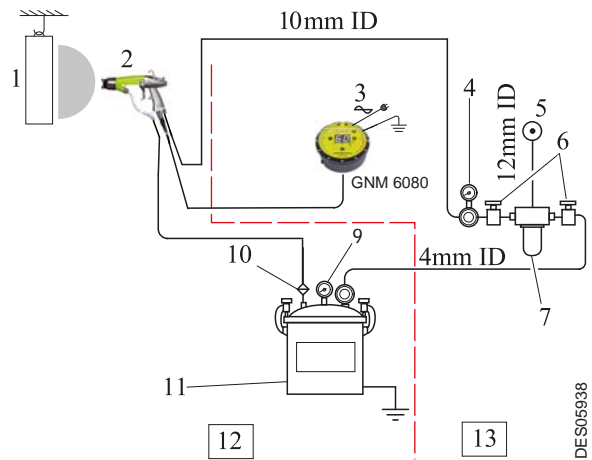

Note: m<sup>3</sup>/h volume at 1013 mbar atmospheric pressure and a temperature of 20°C (68°F).  
 You are advised to fit a pneumatic stirrer on the pressure tank to stir the paint.  
 A filter with a screen should be fitted at the spray gun paint hose inlet.



**WARNING :** For the safety of the painter, the pressure tank and the paint filter, if it is metal, must always be electrically grounded.

## 8. Operation

### 8.1. Paint Recommendations

In general, all paints and clear coats used with conventional pneumatic spray guns (including slightly metallic paints) can be used in the normal way with the **Nanogun Airspray** spray gun.

#### 8.1.1. Viscosity

The best results are obtained with a viscosity ranging from 25 to 30 seconds, measured with AFNOR cup 4. However, paints with a lower or higher viscosity (for example 14 to 50 seconds or more) can be sprayed.

#### 8.1.2. Resistivity

Use a paint whose resistivity is suitable for the **Nanogun Airspray** spray gun model that you are using. Optimum resistivity ranges from 0.5 to 500 M $\Omega$ .cm. Low resistivity promotes a good wraparound effect, but there may be back spray onto the operator if the booth is inadequately ventilated, especially when using the round spray.

Much lower resistivity (for example 0.1 M $\Omega$ .cm) will short circuit the high voltage and therefore prevent any wraparound effect. High resistivity (e.g. 1000 M $\Omega$ .cm) will significantly reduce the wraparound effect which will be greatly reduced. Paint resistivity can be easily checked using the SAMES KREMLIN AP 1000 resistivohmmeter.



## 8.2. Settings of the spraying parameters

These settings are given for information and can be subject to variations in particular due to the temperature and to the ambient humidity.

### Viscosity of paint 20 sec CA4 and length of paint hose 7.5 m:

Flat spray nozzle with high efficiency cap ring (P/N 900009014)	Paint flow in cc/min	130	285	525	750	900
	Paint pressure in bar	0,3	0,8	1,5	2,6	3,1
	Air compressed flow in Nm <sup>3</sup> /h	10,3	15,8	19,4	25,2	30
	Air compressed pressure in bar *	1,4	2,4	3,1	4,2	6
	Width of spray in cm**	11	24	35	37	37
	Finishing	Good	Good	Good	Good	Average
Round spray nozzle Ø: 6 mm	Paint flow in cc/min	70	200	400	650	
	Paint pressure in bar	0,4	1	2	4	
	Air compressed flow in Nm <sup>3</sup> /h	6,6	7,8	12,2	16,8	
	Air compressed pressure in bar *	1,2	1,5	2,7	4	
	Width of spray in cm**	8	8	15	19	
	Finishing	Good	Good	Good	Good	
Round spray nozzle Ø: 8 mm	Paint flow in cc/min	120	150	315	660	
	Paint pressure in bar	0,2	0,3	0,6	1,5	
	Air compressed flow in Nm <sup>3</sup> /h	6,6	7,8	11,3	16,8	
	Air compressed pressure in bar *	1	1,3	2,1	3,4	
	Width of spray in cm**	8	9	11	20	
	Finishing	Good	Good	Good	Good	
Round spray nozzle Ø: 12 mm	Paint flow in cc/min	135	150	310	660	
	Paint pressure in bar	0,2	0,3	0,6	1,5	
	Air compressed flow in Nm <sup>3</sup> /h	8,4	9,4	12,8	22,5	
	Air compressed pressure in bar *	1,2	1,5	2,2	4,3	
	Width of spray in cm**	NS***	11	13	21	
	Finishing	Good	Good	Good	Good	

- \* Dynamic pressure measured in the inlet of the supply hose of compressed air when the spray gun is in use.
- \*\* Maximum size of the spray when the circuit of additional air is opened at most with a distance of 250 mm spraying and a electrostatic tension of 60 kV.
- \*\*\* Too low flow, coat not closed considering the time of spraying.

Viscosity of paint 50 sec CA4 and length of paint hose 7.5 m:

Flat spray nozzle with high efficiency cap ring (P/N 900009014)	Paint flow in cc/min	120	285	495	750	915
	Paint pressure in bar	0,75	1,8	3,2	5	6,5
	Air compressed flow in Nm <sup>3</sup> /h	10,3	15,8	19,4	25,2	30
	Air compressed pressure in bar *	1,4	2,4	3,1	4,2	5,5
	Width of spray in cm**	11	24	35	37	37
	Finishing	Good	Good	Good	Good	Average
Round spray nozzle Ø: 6 mm	Paint flow in cc/min	The use of a 6 mm injector to spray a viscous product is not advised.  Only ones of the tests of spraying allow to determine the values of pressure product and compressed air to apply.				
	Paint pressure in bar					
	Air compressed flow in Nm <sup>3</sup> /h					
	Air compressed pressure in bar *					
	Width of spray in cm**					
	Finishing					
Round spray nozzle Ø: 8 mm	Paint flow in cc/min	140	300	640		
	Paint pressure in bar	0,9	1,8	3,8		
	Air compressed flow in Nm <sup>3</sup> /h	7,8	11,3	16,8		
	Air compressed pressure in bar *	1,3	2,1	3,4		
	Width of spray in cm**	9	11	20		
	Finishing	Good	Good	Good		
Round spray nozzle Ø: 12 mm	Paint flow in cc/min	150	290	740		
	Paint pressure in bar	0,8	1,6	3,9		
	Air compressed flow in Nm <sup>3</sup> /h	9,4	12,8	22,5		
	Air compressed pressure in bar *	1,5	2,2	4,3		
	Width of spray in cm**	11	13	21		
	Finishing	Good	Good	Good		

- \* Dynamic pressure measured in the inlet of the supply hose of compressed air when the spray gun is in use.
- \*\* Maximum size of the spray when the circuit of additional air is opened at most with a distance of 250 mm spraying and a electrostatic tension of 60 kV.

Viscosity of paint 50 sec CA4 and length of paint hose 15 m:

Flat spray nozzle with high efficiency cap ring (P/N 900009014)	Paint flow in cc/min	100	300	500	680	
	Paint pressure in bar	1,2	3,2	5,4	7	
	Air compressed flow in Nm <sup>3</sup> /h	10,3	15,8	19,4	25,2	
	Air compressed pressure in bar *	1,4	2,4	3,1	4,2	
	Width of spray in cm**	11	24	35	37	
	Finishing	Good	Good	Good	Good	
Round spray nozzle Ø: 6 mm	Paint flow in cc/min	The use of a 6 mm injector to spray a viscous product is not advised.  Only ones of the tests of spraying allow to determine the values of pressure product and compressed air to apply.				
	Paint pressure in bar					
	Air compressed flow in Nm <sup>3</sup> /h					
	Air compressed pressure in bar *					
	Width of spray in cm**					
	Finishing					
Round spray nozzle Ø: 8 mm	Paint flow in cc/min	150	300	650		
	Paint pressure in bar	1,7	3,2	6,5		
	Air compressed flow in Nm <sup>3</sup> /h	7,8	11,3	16,8		
	Air compressed pressure in bar *	1,3	2,1	3,4		
	Width of spray in cm**	9	11	20		
	Finishing	Good	Good	Good		
Round spray nozzle Ø: 12 mm	Paint flow in cc/min	150	300	650		
	Paint pressure in bar	1,5	2,9	6		
	Air compressed flow in Nm <sup>3</sup> /h	9,4	12,8	22,5		
	Air compressed pressure in bar *	1,5	2,2	4,3		
	Width of spray in cm**	11	13	21		
	Finishing	Good	Good	Good		

- \* Dynamic pressure measured in the inlet of the supply hose of compressed air when the spray gun is in use.
- \*\* Maximum size of the spray when the circuit of additional air is opened at most with a distance of 250 mm spraying and a electrostatic tension of 60 kV.

## 9. Misuse of the Apparatus

The non-exhaustive list below describes some major misuses of a paint spraying device.



**WARNING :** SAMES KREMLIN would like to remind users that the instructions below **MUST** be strictly complied with.

<b>It is forbidden to</b> install the control module in a potentially explosive atmosphere.
<b>It is forbidden to</b> subject the paint or air hose or spray gun power cable to excessive and repeated tension strain.
<b>It is forbidden to</b> disconnect the electrical connector in a potentially explosive atmosphere.
<b>It is forbidden to</b> leave air or paint hoses trailing on the floor or in areas where they are liable to be crushed or broken by industrial vehicles.
<b>It is forbidden to</b> use the <b>Nanogun Airspray</b> to spray a liquid other than a paint or clear coat.
<b>It is forbidden to</b> drop the spray gun or subjecting it to impacts.
<b>It is forbidden to</b> leave the spray gun on the ground.
<b>It is forbidden to</b> use the spray gun to handle or move the parts to be painted.
<b>It is forbidden to</b> leave the spray gun to soak in solvent or spraying it with solvent.
<b>It is forbidden to</b> spray solvent before switching off the control module.
<b>It is essential to</b> connect the control module ground terminal to the paint apparatus ground terminal.
<b>It is essential to</b> tighten the two safety screws on the electrical connector.

## 10. Maintenance

### 10.1. Preventive maintenance table

Carry out when the maintenance indicator light of the GNM 6080 is ON.

Sub-assembly	Description	Part Number	Qty	Minimum replacement frequency
Nozzle support (JR/JP)	O-ring	J3STKL094	1	3 months
Barrel	Seal cartridge	910014338	1	6 months or 500.000 operations (*)
	O-ring (Seal cartridge )	J3STKL005	1	3 months
	O-ring chemically inert	J3STKL032	1	6 months
	O-ring FEP viton	J2FENV435	1	12 months
	O-ring chemically inert	J3STKL078	1	12 months
	O-ring chemically inert	J3STKL002	1	12 months
	O-ring chemically inert	J3STKL019	1	12 months
Handle	O-ring (electrical connector)	160000041	1	12 months
	O-ring (handle base))	160000067	1	12 months
	O-ring (air nipple)	J2FTCF018	1	12 months
		J3STKL018	1	12 months
Air valve	O-ring - chemically inert (outer of valve)	J3STKL005	1	12 months
	O-ring - chemically inert (inner of valve)	J3STKL032	1	12 months
	Sealing ring	900010256	1	12 months



**WARNING :** (\*): As soon as one of both terms is reached.



**WARNING** : Before any maintenance work on the spray gun, always refer to the health and safety instructions ([see § 2 page 8](#)).

- Disconnect the control module from the power supply.
- Check that the air and paint circuits are not pressurised.
- Dump the paint circuit.

## 10.2. Electropneumatic coupling

- **Step 1:** Remove paint hose. Loosen the paint hose nut with a 15mm open-ended spanner.



- **Step 2:** Unscrew the fitting nut of the 7/10 polyurethane air hose with an open-ended spanner of 16.

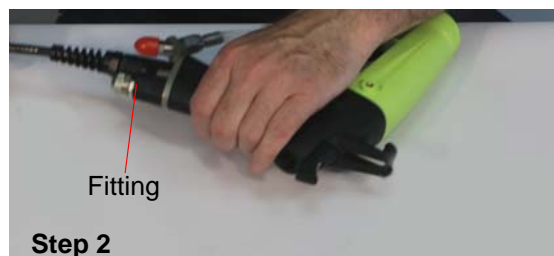

- **Step 3:** Remove the low voltage cable with a 3mm allen key, unscrew the two captive screws from the electropneumatic coupling.



- **Step 4:** Pull the electropneumatic coupling apart to disconnect.



- **Step 5:** Loosen the air nipple using a 14mm open-ended spanner and replace it.

### 10.3. Paint Hoses

#### 10.3.1. Paint hose - QD version (HR)

- **Step 1:** Side handle, unscrew the fitting using a 15mm open-ended spanner.



- **Step 2:** Release the paint hose from base.



- **Step 3:** Using a 21 mm open-ended spanner, unscrew the upper nut of the paint hose, then stop loosening manually by maintaining the nut of bottom.



- **Step 4:** Check that the seal of the paint nut is in place. Check that the two olives (P/N 910018200) are installed on the paint hose (they can be lost in the event of leakage caused by inadequate tightening). In case olives must be removed, replace them necessarily by news.



**To reassemble**, follow the steps in reverse order. Tighten manually the upper paint hose nut until it levels the reinforcement of the barrel.

### 10.3.2. Paint hose LR-MR

- **Step 1:** Unscrew the stuffing box locknut using a 27mm open-ended spanner, release the stuffing box from the bracket.



- **Step 2:** Using a 21mm open-ended spanner, loosen the upper paint hose nut. Unscrew the nut, whilst rotating the hose



**To reassemble,** tighten the lower paint hose nut until it stops. Position the stuffing box locknut above the bracket and the stuffing box below in the hexagonal socket. Tighten the stuffing box locknut onto the bracket.



#### 10.4. Spray head assembly Round Spray and Flat spray nozzles

- **Step 1:** Unscrew the air cap ring by hand, then remove the air cap.



- **Step 2:** Unscrew the nozzle assembly and the nozzle support nut using the multipurpose spanner.



- **Step 3:** Remove the nozzle support, pulling it in a direction parallel to the barrel axis. Replace the seal every three months ([see § 13.8 page 57](#)).



To reassemble, follow the steps in reverse order.

## 10.5. Barrel

- **Step 1: Seal cartridge:** Extract the cartridge from the barrel using the multipurpose spanner. The cartridge should be replaced every time it is disassembled.

If the o-ring at the front of the cartridge is to be replaced, removed it with a screwdriver, insert the new o-ring, ensuring it is positioned correctly.

**When reassembling,** ensure the cartridge is inserted in the correct orientation (white seal facing outwards). Push the cartridge until it clips into the barrel. Coat the white seal and the anti-extrusion ring with a fine layer of vaseline.

- **Step 2: Seal:** Replace the seal every three months. Remove the seal using a 2.5mm screwdriver, taking care to avoid damaging the barrel.

- **Step 3: HV contact:** Unscrew the HV contact using a 4mm socket wrench. The fibre washer should always be replaced whenever the device is disassembled. Replace the HV contact if necessary, then screw back into the barrel.



## 10.6. Paint needle

- **Step 1:** Unscrew the notched button at the rear of the spray gun, retrieve the spring.



- **Step 2:** Press the trigger and pull manually the paint needle towards the back.



**WARNING :** Every 4 or 5 reassemblies, add some dielectric grease (Ref.: H1GSYN037) in the passage channel in the barrel.

## 10.7. Switch

- **Step 1:** With a 5,5 mm screwdriver, unscrew the shouldered screw. Pull upwards the lever of the switch.



- **Step 2:** Replace the o-ring ([see § 13.4 page 53](#)). Insert the new switch into its housing. Coat with low threadlocker the fastening screw and tighten the screw so that the switch is slightly resistant.



## 10.8. Trigger

- **Step 1:** Using a screwdriver, unscrew both shouldered screws and release both sides of the trigger.



### Reassembling the trigger:

- Put in place one on the sides of the trigger on its shoulder then slide the other side into its housing.



## 10.9. Air valve

- **Step 1:** Remove the paint needle ([see § 10.6 page 35](#)).
- **Step 2:** Unscrew the air valve stop nut using a 18 mm open-ended spanner.

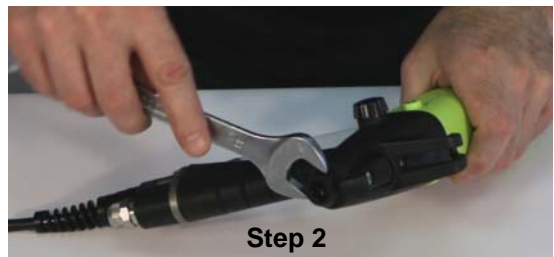

Position the gun barrel to the top and recover the spring and the air valve. If the parts do not fall, tap in the palm of the hand.



or use the paint needle to extract the air valve.



### 10.9.1. Repairing the air valve

Three levels of maintenance are possible:

- **Level 1:** Standard level of maintenance because the body of the air valve does not undergo any friction nor wear.
- **Level 2:** Corrective maintenance, carry out if the valve body is damaged.
- **Level 3:** Exceptional maintenance, carry out if the magnet is lost or broken.

**Level 1: Replacement of the three o-rings** (P/N J3STKL032 inner ring, J3STKL005 outer ring and 900010256 conical seal.

- For three seals, extract the old by taking care of not damaging the body of the air valve (but they can be destroyed).
- The conical seal must be pushed up to its click-and-ratchet work on the body of the air valve by taking care not to damage its conical reach.

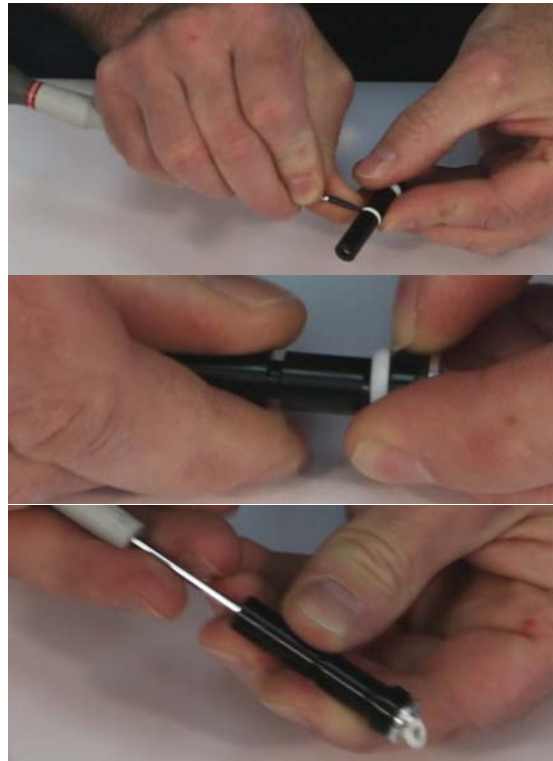

**Level 2: If the valve body is damaged.**

- Extract manually the aluminium ring or put a M4 screw in the ring, pull out in the axle of the part, and remove the magnet by taking care to locate its direction (silver plated side / black side).

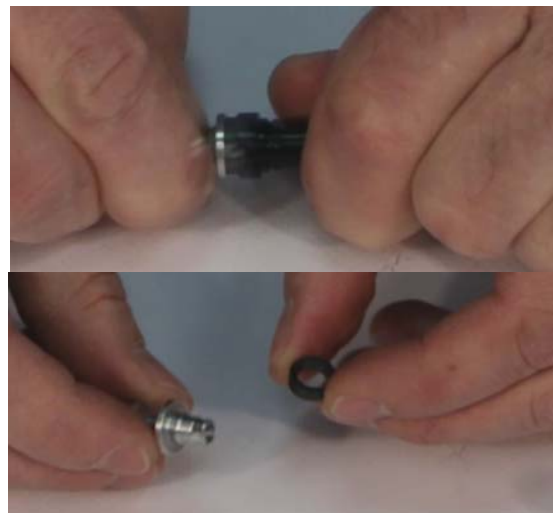

- Put in place the magnet in the right direction ([see § 10.9.1.1 page 38](#)) and retain the ring in the body of the air valve by pushing firmly with the finger.

**After complete reassembly of the spray gun, check the activation and the stop of the high voltage. If the high voltage is permanently engaged or does not cut itself: check the direction of the magnet.**



### Level 3: If the magnet is broken or lost.

- Replace the air valve (P/N 910015405) ([see § 10.9 page 36](#)).  
Before using the spray gun, check the activating and the stop of the high voltage.

If the high voltage is permanently activated, disassemble the handle and remove one of the washers which adjust the position of the sensor reed, proceed step by step, don't remove several washers at the same time.

If the high voltage does not start, disassemble the handle and add a washer to adjust the position of the sensor reed, proceed step by step, don't add several washers at the same time.



**WARNING :** Various thicknesses of washers can be in position, begin always to add or remove the finest.

#### 10.9.1.1. Direction of assembling of the magnet

- **Case Nr 1:** For the guns of the type 1 (see serial number). Rear support without groove, the side silver plated of the magnet must be in contact with the shoulder of the rear support.
- **Case Nr 2:** For the guns of the type 2 (see serial number). Rear support with grooves, the black side of the magnet must be in contact with the shoulder of the rear support.

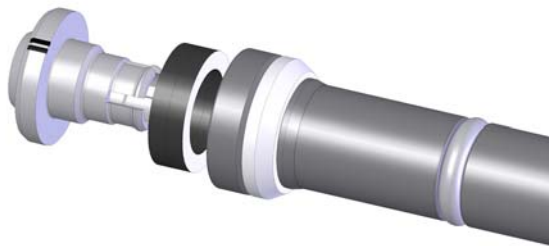

### 10.10. Fixing hook

- Put the switch in position " I ". With a 5,5mm screwdriver, unscrew the shouldered screw and remove the hook by pulling upwards.



### 10.11. High voltage cascade

- **Step 1:** Remove the trigger ([see § 10.8 page 36](#)), remove the paint needle.

- **Step 2:** Loosen the 4 screws fastening the barrel on the handle with a 2mm Phillips screwdriver.

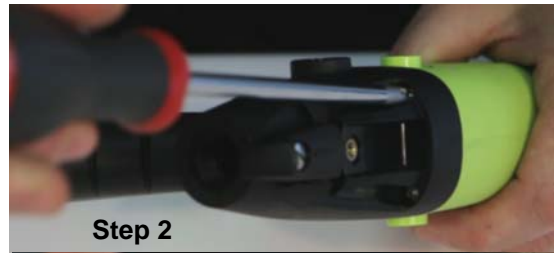

- **Step 3:** Unscrew, manually or with a small flat pliers, the three connection wires of the high voltage unit, pull carefully the contacts towards the back.



- **Step 4:** Remove the high voltage contact in front of the barrel ([see § 10.5 page 34](#)). Withdraw the high voltage unit.



**WARNING :** Attention with the colors (terminal 1: black, terminal 2: green, terminal 3: pink).

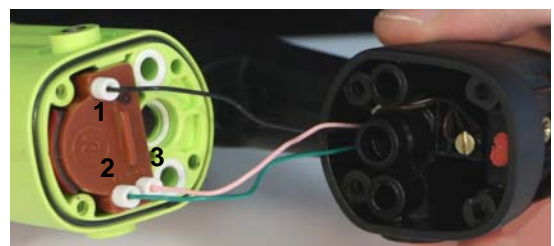

**To reassemble, follow the steps in reverse order.**

Replace the high-voltage cascade. **Coat the cascade with dielectric grease** (P/N # H1GSYN037) then insert it into its housing.

Push the cascade fully into the barrel. Connect the three wires and tighten the screws. Check the wear of the o-rings, replace if necessary.

## 10.12. Barrel

- **Step 1:** Remove the trigger [see § 10.8 page 36](#), and the paint needle.
- **Step 2:** Unscrew the four screws fastening the barrel on the handle.
- **Step 3:** Unscrew manually or with a small flat pliers the three connection wires of the high voltage unit, pull carefully the contacts towards the back.

- **Step 4: Replace the o-rings of the air ducts and the air valve (Step 3: not obligatory):** Remove and replace the three o-rings.



- **Step 5: Replace the o-ring barrel/handle (Step 3: obligatory):** Remove and replace the o-ring. Replace this o-ring every year.



- **Step 6: Replace the o-ring back of paint needle:** Remove and replace the o-ring.



For reassembling follow the steps in reverse order.



### 10.13. Handle

- **Step 1:** Separate the barrel from the handle.
- **Step 2: Handle base**  
Unscrew the air nipple using a 6mm allen key. Replace the seals every 12 months.
- **Step 3:** Undo both K35 x 14 screws with a 2mm Phillip's screwdriver. Change the fibre washers each time the screws are removed.
- **Step 4:** Lift the base to access the handle base seal. This seal should be replaced every 12 months.
- **Step 5:** Push the electrical connector to release it and remove from the base. Replace the seal of the connector every 12 months.
- **Step 6: Replacement of the base:** unscrew the screw of the ground wire using a 0 Phillip's screwdriver, withdraw it and replace it.



**To reassemble**, follow the steps in reverse order. Insert the connector pin back into the base foolproofing slot.

Coat the air nipple seals with dielectric lubricant.

Tighten the air nipple to 1.5 N.m torque.

Tighten the two K35 x 14 screws to 1.3 N.m torque.

## 10.14. Electric diagrams

### 10.14.1. Connection cable GNM 6080 / Nanogun Airspray

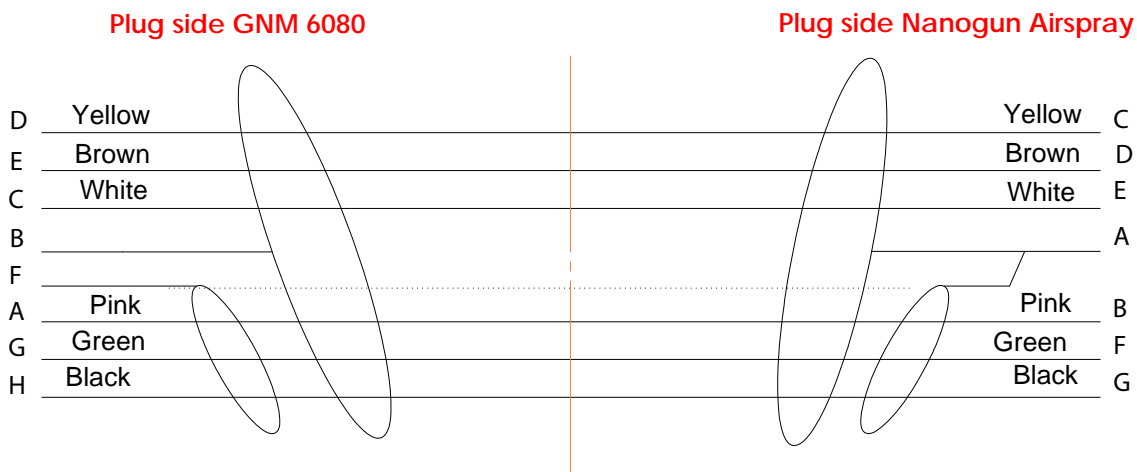

### 10.14.2. GNM 6080 trigger cable

A	Pink	Primary transformer HVU 3
B		Shield
C	White	REED sensor (trigger)
D	Yellow	Dallas chip
E	Brown	0V commun puce / reed
F		Third shield
G	Green	Primary transformer HVU 3
H	Black	Return IHV 1

Plug side GNM 6080

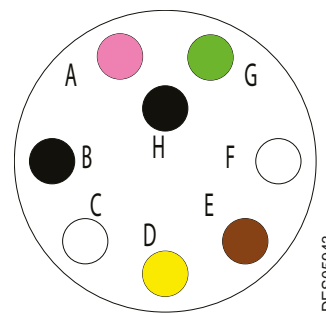

DES05943

(\*)

Switch "open": Nanogun Airspray trigger releases.

Switch "closed" : Nanogun Airspray trigger activated.

Characteristics of the switch: 0.5 A maxi / 24 VAC/DC maxi.

## 11. Cleaning

Always refer to the health and safety instructions before carrying out any work on the spray gun ([see § 2 page 8](#)).

### 11.1. Cleaning the product circuit

- Disconnect the **GNM 6080** control module.
- Install a bucket of solvent in place of the paint container.
- Open the recirculation valve to clean the pump.
- Close the recirculation valve and hold down the trigger until clean solvent comes out of the spray gun nozzle/tip.

### 11.2. Cleaning the spray gun

The spray gun must be cleaned immediately after use and at the end of the day, as with all paint guns. The cleaning procedure described below should be followed carefully:



**WARNING :** It is formally forbidden to plunge the Nanogun Airspray into solvent.



**WARNING :** Use an appropriate solvent: non-greasy, non-chlorinated and with a high resistivity.

- **Step 1:** Disconnect the **GNM 6080** control module.
- **Step 2:** Depressurise the spray gun air circuit.
- **Step 3:** Dump the spray gun paint circuit and rinse with an appropriate solvent ([see § 2.4 page 10](#)).
- **Step 4:** Depressurise the spray gun paint circuit.
- **Step 5:** Dry the spray gun air cap with a soft, dry, lint-free cloth.
- **Step 6:** Unscrew the spray gun air cap ring and remove the air cap ([see § 10.4 page 33](#)).
- **Step 7:** Clean the air cap with a solvent-dampened brush and then wipe dry.
- **Step 8:** Reassemble the air cap and ring.
- **Step 9:** Dry the compressed air spray gun (facing downwards) before restarting the **GNM 6080** control module.



**WARNING :** Never disassemble the needle assembly when the paint hose contains paint or solvent.



**WARNING :** Never soak or immerse the spray gun in solvent.

When cleaning the nozzle/tip, always point the spray nozzle/tip towards the ground to prevent solvent or paint from flowing into the barrel ducts.



**WARNING :** After cleaning, the ducts and supply hose must be dried with compressed air to remove all traces of solvent.

### 11.3. Waste disposal

Waste generated by use of the apparatus (spent solvent, unused paint, residue, dirty cloths, paint booth slurry, water-wash spray booth run-off, used dry filters, ventilation air etc.) must be removed, transported and disposed of in strict compliance with the applicable local regulations.

## 11.4. Demolition and Recycling

### 11.4.1. Nanogun Airspray



**WARNING :** All the parts can be contaminated by paint residues and/or of solvent. Before proceeding to the demolition of the equipment, clean the spray gun and more particularly the inside of paint hoses with an appropriate cleaning product and air-drying them with compressed air.

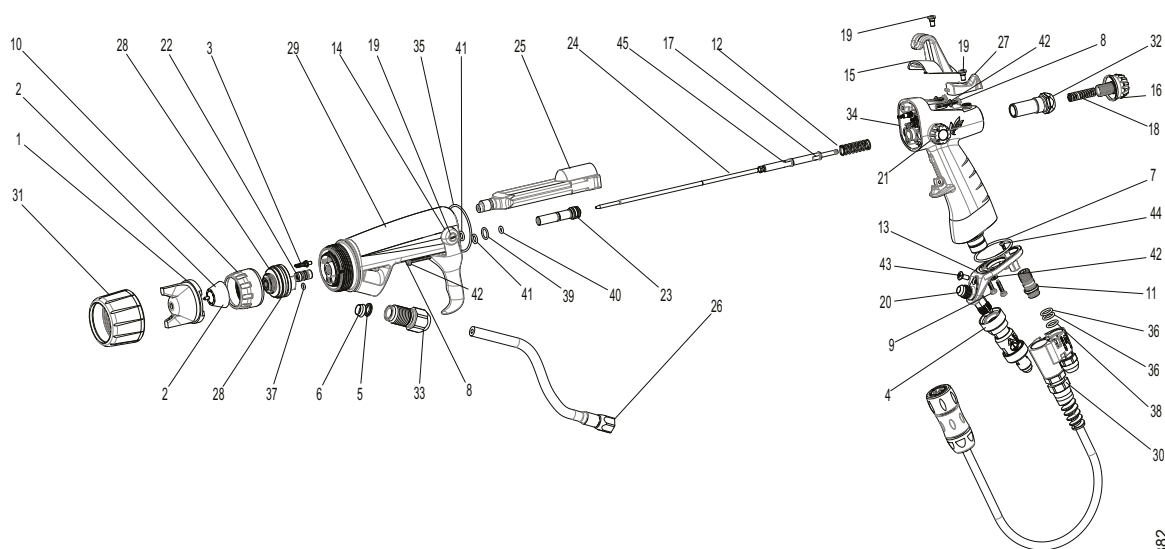

DES05882

Item	Material
<b>Spraying area</b>	
1,6, 22,28,33,37	Plastics charged glass fiber or kevlar
31	Plastic charged PTFE or chemically inert rubber
28	Plastics charged with fibers, titanium
2	Plastics and stainless steel
5, 22	Chemically inert rubber
3*	Brass
26	Polyethylene and stainless steel
<b>Barrel area</b>	
14, 29*	Plastic charged glass fiber
8, 19	Stainless steel
35, 39,40, 41, 42	Chemically inert rubber or fiber O-rings
25	Plastic, copper, steel, ceramic, electronic and electric components ROHs
<b>Air and product valve area</b>	
23, 24*	Tungsten, PEEK, stainless steel, chemically inert rubber, PTFE, magnet (iron), aluminium
12*, 18*, 45*	Stainless steel
16*, 17*, 21	Aluminium
32	Plastics, chemically inert rubber

<b>Handle area</b>	
15, 34	Plastics charged glass fiber, stainless steel, brass, copper
Not shown	Sensor position trigger: electric components ROHs, plastic, copper
	connector at the bottom of the handle: ROHs electronic components, plastic, copper
19	Stainless steel
27	Plastic charged glass fiber, magnet (iron)
<b>Area base plate of handle connection towards the control module</b>	
13	Aluminium
11, 20, 42, 43, 44	Stainless steel
7, 36	Rubber
30	Plastics charged glass fiber, stainless steel, copper
<b>Product /air hose area</b>	
Not shown	Air hose: PU
Not shown	Product hose: polyethylene or elastomerized polyethylene
	Connections: zinc coated steel and stainless steel
	Sheath: polyamide
	Stuffing box: plastic charged
	Fitting: zinc coated steel and stainless steel

\* These components (3, 12, 16, 17, 18, 24, 29, 45) can be soiled with dielectric grease.

11.4.2. GNM 6080

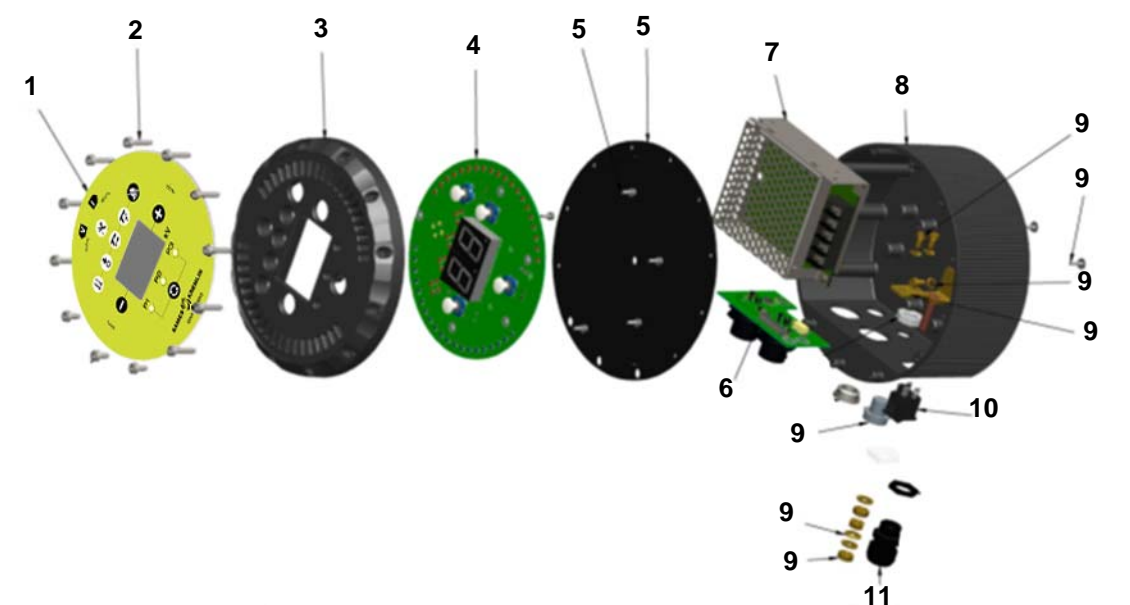

Item	Description	Material
1	Keyboard / front face*	Plastic
2	Fastening screw of front face	Stainless steel
3	Support of main board and front face	Aluminium
4	Main board	Electric and electronic components, printed circuit ROHs
5	Rear metal sheet and fastening screw	Steel
6	Connector board	Electric and electronic components, printed circuit ROHs
7	Electric power	Electric and electronic components, printed circuit ROHs
8	Box	Aluminium
9	Fixation accessories	Steel and brass
10	Electric switch	Electric component ROHs
11	Stuffing box	Plastic
<b>Not shown</b>		
12	Power cable	Plastic and copper

\* Attention, this component can be soiled with dielectric grease.

## 12. Troubleshooting Guide

Faults	Possible causes	Remedies
Irregular paint spray	Air in paint circuit	Dump the paint circuit
	Paint flow too low	Increase pressure in pump or pressure tank
	Impurities in circuit	Check filter, then drain circuit
	Paint tank empty (or nearly)	Refill paint tank
	Paint viscosity too high	Check paint viscosity
Paint not fluid enough when leaving spray gun	Blocked nozzle/tip	Clean nozzle/tip
	Needle does not retract	Check needle assembly
	Clogged filter	Clean filter
	Insufficient pump pressure	Check pump
	Paint viscosity too high	Check paint viscosity
Paint flows out continuously	Dia 6.35 mm paint hose clogged	Unblock or replace paint hose
	Needle is obstructed and cannot close	Remove nozzle/tip holder and clean holder and seat. Clean needle tip
	Worn needle	Replace needle and, if necessary, the nozzle/tip holder
Paint comes out of air cap air holes	Nozzle/tip holder damaged	Replace nozzle/tip holder
	Nozzle/tip insufficiently tightened against seat	Tighten nozzle/tip
	Damaged cartridge	Replace cartridge
Poor spraying quality	Damaged paint seal	Replace seal
	Nozzle/tip partially blocked	Clean nozzle/tip
	Paint flow too weak	Increase paint flow
	Viscosity too high	Dilute paint
	Insufficient air for spraying	Increase air pressure
	Paint flow too high	Reduce paint flow
	Paint injector damaged	Replace the injector
Orange peel effect	Solvents evaporating too quickly	Use heavier solvents
	Paint droplets too large	Increase spraying distance
		Dilute paint
		Increase spraying air pressure
		Decrease nozzle/tip size
	Increase the electrostatic effect	

Faults	Possible causes	Remedies
Paint running	Solvents evaporating too slowly	Use lighter solvents
	Spraying applied too slowly	Reduce paint flow
		Increase spraying air pressure
		Reduce the electrostatic effect
Paint spray over-loaded in middle	Paint flow too high	Reduce paint flow
		Increase air pressure
	Nozzle/tip too large	Use a smaller nozzle/tip
	Paint viscosity too great	Dilute paint
	Air holes partially blocked	Clean spray head
Insufficient electro-static effect	High voltage power not on	See display on control module
	High voltage power insufficient	Increase high voltage power
	Distance between spray head and part too great	Check <b>Nanogun Airspray</b> output voltage
		Spray from between 200 and 300 mm away
	Part not grounded	Clean hooks. Check grounding connection of parts conveyor
	Excessive ventilation	Reduce paint booth air extraction rate, ensuring the applicable regulations are still complied with
	Spraying air pressure too high	Reduce spraying air pressure
	Paint flow too high	Reduce paint flow
	Product resistivity too high	Reduce product resistivity to obtain $\rho < 500\text{M}\Omega.\text{cm}$
	Control module short circuit: - external	Clean outside of the spray gun with a non-conductive solvent ( $\rho > 15 \text{ M}\Omega.\text{cm}$ )
		Use a new, clean and dry case
	Control module short circuit: - via needle assembly	Replace seal cartridge and needle
Control module short circuit: - via air channels	Clean the air channels of the barrel	
Control module short circuit: - via product hose	Increase the resistivity of paint so that $\rho > 5 \text{ M}\Omega.\text{cm}$	
Operator gets electric shocks when touching the part	Part not grounded or poorly grounded	



### 13. Spare Parts

#### 13.1. Nanogun Airspray spray guns low pressure for high resistivity (HR) solvent paint $\rho > 10M\Omega.cm$

Round Spray Versions  
JR 06 / JR 08 / JR 12

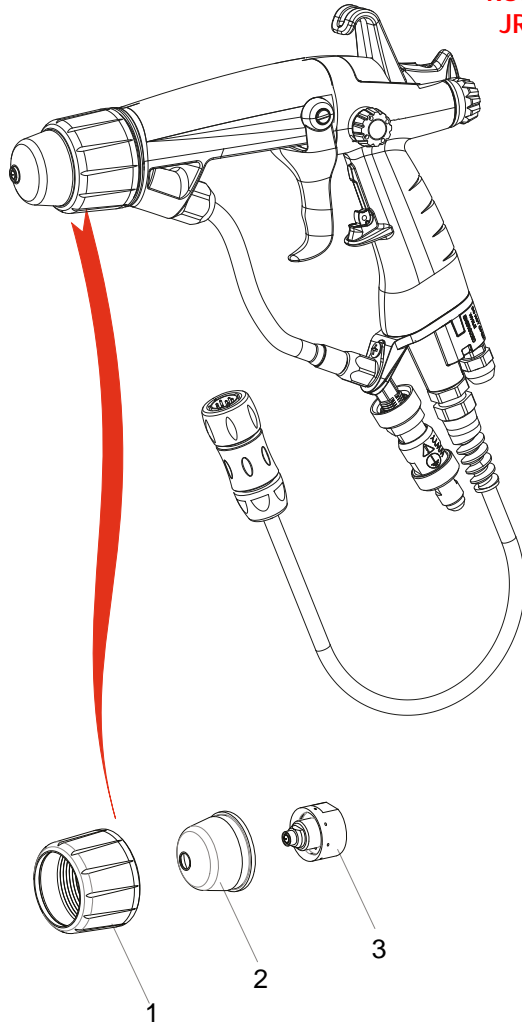

Flat spray Version

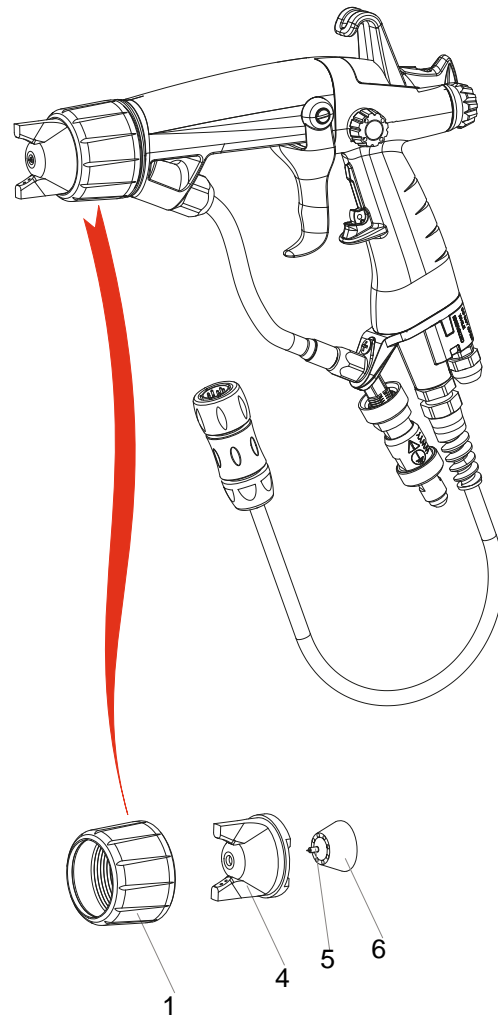

DIES05940

For the various options: [see § 13.15 page 64.](#)

Item	Part number	Description	Qty	Unit of sale	Spare Part Level (*)
	910018773	Nanogun Airspray JR 06 LP HR round spray	1	1	-
	-	Nanogun Airspray spray gun ( <a href="#">see § 13.4 page 53</a> )	-	-	-
1	910015921	Air cap ring ( <a href="#">see § 13.7 page 57</a> )	1	1	3
2	900011365	Super vortex cap	1	1	3
3	910018322	JR06 Round spray nozzle ( <a href="#">see § 13.9 page 58</a> )	1	1	1
Not shown					
	050123306	M1/2 JIC adapter - F3/8NPS paint hose	1	1	3

Item	Part number	Description	Qty	Unit of sale	Spare Part Level (*)
	910016712	Nanogun Airspray JR 08 LP HR round spray	1	1	-
	-	Nanogun Airspray spray gun ( <a href="#">see § 13.4 page 53</a> )	-	-	-
1	910015921	Air cap ring ( <a href="#">see § 13.7 page 57</a> )	1	1	3
2	900010503	Super vortex cap	1	1	3
3	910003847	JR08 Round spray nozzle ( <a href="#">see § 13.9 page 58</a> )	1	1	1
Not shown					
	050123306	M1/2 JIC adapter - F3/8NPS paint hose	1	1	3

Item	Part number	Description	Qty	Unit of sale	Spare Part Level (*)
	910016711	Nanogun Airspray JR 12 LP HR round spray	1	1	-
	-	Nanogun Airspray spray gun ( <a href="#">see § 13.4 page 53</a> )	-	-	-
1	910015921	Air cap ring ( <a href="#">see § 13.7 page 57</a> )	1	1	3
2	900010504	Super vortex cap	1	1	3
3	910003920	JR12 Round spray nozzle ( <a href="#">see § 13.9 page 58</a> )	1	1	1
Not shown					
	050123306	M1/2 JIC adapter - F3/8NPS paint hose	1	1	3

Item	Part number	Description	Qty	Unit of sale	Spare Part Level (*)
	910016710	Nanogun Airspray JP LP HR Flat spray	1	1	-
	-	Nanogun Airspray spray gun ( <a href="#">see § 13.4 page 53</a> )	-	-	-
1	910015921	Air cap ring ( <a href="#">see § 13.7 page 57</a> )	1	1	3
4	900009014	High efficiency air cap	1	1	1
5	446028	Electrode	1	5	1
6	1406402	SP nozzle assembly	1	1	1
Not shown					
	050123306	M1/2 JIC adapter - F3/8NPS paint hose	1	1	3

(\*) Level 1: Standard preventive maintenance.  
 Level 2: Corrective maintenance.  
 Level 3: Exceptional maintenance.

13.2. Nanogun Airspray, low Pressure spray guns for solvent paint  $0.5 \text{ M}\Omega\cdot\text{cm} < \rho < 500 \text{ M}\Omega\cdot\text{cm}$



**WARNING** : Nanogun Airspray Low Pressure low resistivity spray guns include the same components, except the product hoses.

Part number	Description	Qty	Unit of sale	Spare Part Level
910018774-075	Nanogun Airspray JR 06 LP LR, hose length: 7.5 m	1	1	-

Part number	Description	Qty	Unit of sale	Spare Part Level
910018774-150	Nanogun Airspray JR 06 LP LR, hose length: 15 m	1	1	-

Part number	Description	Qty	Unit of sale	Spare Part Level
910017190-075	Nanogun Airspray JR 08 LP LR, hose length: 7.5 m	1	1	-

Part number	Description	Qty	Unit of sale	Spare Part Level
910017190-150	Nanogun Airspray JR 08 LP LR, hose length: 15 m	1	1	-

Part number	Description	Qty	Unit of sale	Spare Part Level
910017189-075	Nanogun Airspray JR 12 LP LR, hose length: 7.5 m	1	1	-

Part number	Description	Qty	Unit of sale	Spare Part Level
910017189-150	Nanogun Airspray JR 12 LP LR, hose length: 15 m	1	1	-

Part number	Description	Qty	Unit of sale	Spare Part Level
910017188-075	Nanogun Airspray JP LP LR, hose length: 7.5 m	1	1	-

Part number	Description	Qty	Unit of sale	Spare Part Level
910017188-150	Nanogun Airspray JP LP LR, hose length: 15 m	1	1	-

### 13.3. Nanogun Airspray, low Pressure spray guns for solvent paint $2 \text{ M}\Omega.\text{cm} < \rho < 500 \text{ M}\Omega.\text{cm}$



**WARNING** : Nanogun Airspray Low Pressure middle resistivity spray guns include the same components, except the product hoses.

Part number	Description	Qty	Unit of sale	Spare Part Level
910025604-075	Nanogun Airspray JR 08 LP MR, hose length: 7.5 m	1	1	-

Part number	Description	Qty	Unit of sale	Spare Part Level
910025604-150	Nanogun Airspray JR 08 LP MR, hose length: 15 m	1	1	-

Part number	Description	Qty	Unit of sale	Spare Part Level
910025605-075	Nanogun Airspray JR 12 LP MR, hose length: 7.5 m	1	1	-

Part number	Description	Qty	Unit of sale	Spare Part Level
910025605-150	Nanogun Airspray JR 12 LP MR, hose length: 15 m	1	1	-

Part number	Description	Qty	Unit of sale	Spare Part Level
910025606-075	Nanogun Airspray JP LP MR, hose length: 7.5 m	1	1	-

Part number	Description	Qty	Unit of sale	Spare Part Level
910025606-150	Nanogun Airspray JP LP MR, hose length: 15 m	1	1	-

#### Flow limitation:

The use of a whip limits the maximum flow very little once the extension hose has an inside diameter of 9.5 mm (3/8) as recommended.

The use of an extension of 6.3 mm inside diameter (1/4) is not recommended because it divides the maximum possible flow rate by 2 for low viscosities (20s) and by 3 for higher viscosities (50s).

#### Resistivity limitation:

Using a whip limits the low resistivity value to  $2 \text{ M}\Omega.\text{cm}$  (0.5 for the standard version). However if the application requires an electrostatic voltage lower or equal to 45kV, the minimum resistivity of the product can be  $1 \text{ M}\Omega.\text{cm}$ .

13.4. Nanogun Airspray spray guns, all versions

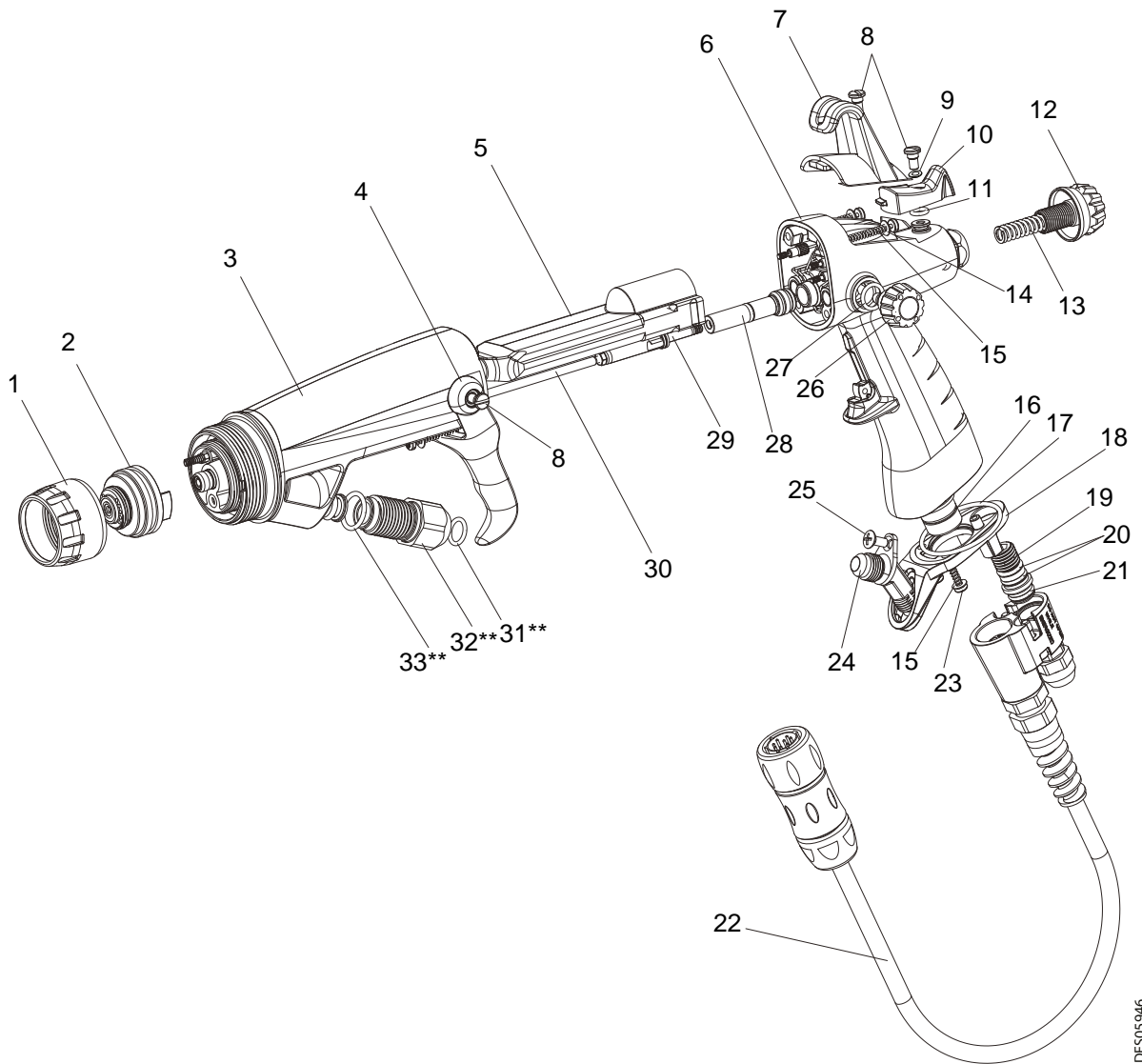

DES05946

Item	Part number	Description	Qty	Unit of sale	Spare Part Level (*)
	-	<b>Nanogun Airspray spray gun</b>	-	-	-
1	900000320	Nozzle nut	1	1	3
2	910015721	<b>Nozzle support</b> ( <a href="#">see § 13.8 page 57</a> )	1	1	1
3	910018202	<b>Equipped barrel</b> ( <a href="#">see § 13.5 page 55</a> )	1	1	3
4	900010237	Trigger	1	1	3
5	910015508	<b>High voltage unit</b>	1	1	3
6	910015944	<b>Nanogun Airspray equipped handle</b>	1	1	3
7	900010239	Fixing hook	1	1	3
8	900010385	Shouldered C M4 screw	4	1	3
9	900013808	PTFE flat washer (included in item10)	1	1	2
10	910018204	<b>ON/OFF button with magnet and o-ring</b> (included in item 6)	1	1	3
11	J3STKL005	Chemically inert o-ring (included in item 10)	1	1	1
12	900010240	Paint flow button	1	1	3
13	900010265	8 bar paint spring	1	1	1
14	250000036	Screw securing handle/barrel	4	1	3
15	J4BRND039	Fibre seal for securing screw	6	1	3
16	160000041	O-ring chemically inert (included in item 6)	1	1	1
17	160000067	O-ring FKM red (included in item 6)	1	1	1
18	900010013	HR spray gun base	1	1	3
	900010009	LR - MR spray gun base	1	1	3
19	910006118	<b>Air nipple</b>	1	1	2
20	J2FTCF018	O-ring FKM black (included in item19)	2	1	1
21	J3STKL018	O-ring chemically inert grey (included in item19)	1	1	1
22	910015869	<b>Electropneumatic coupling sets</b> ( <a href="#">see § 13.11 page 59</a> )	1	1	3
23	250000037	Securing screw of handle base	2	1	3
24	900010605	55° elbow	1	1	3
25	250000214	Elbow securing screw	1	1	3
26	910014166	<b>Lateral tape equipped</b> (included in item 6)	1	1	3
27	J2FTDF121	O-ring FKM black (included in item 26)	1	1	1
28	910018203	<b>Air valve</b> ( <a href="#">see § 13.6 page 56</a> )	1	1	3
29	900010253	Needle rear stop	1	1	3
30	910018219	<b>Needle</b> ( <a href="#">see § 13.10 page 59</a> )	1	1	1
31**	J2FTDF121	O-ring FKM black (included in item 32)	1	1	1
32**	910015931	<b>Paint nut equipped</b>	1	1	2
33**	J2FTCF178	O-ring FKM black (included in item 32)	1	1	1

(\*)

Level 1: Standard preventive maintenance.

Level 2: Corrective maintenance.

Level 3: Exceptional maintenance.

\*\* Except MR version [see § 13.12.3 page 61](#)

### 13.5. Barrel assembly

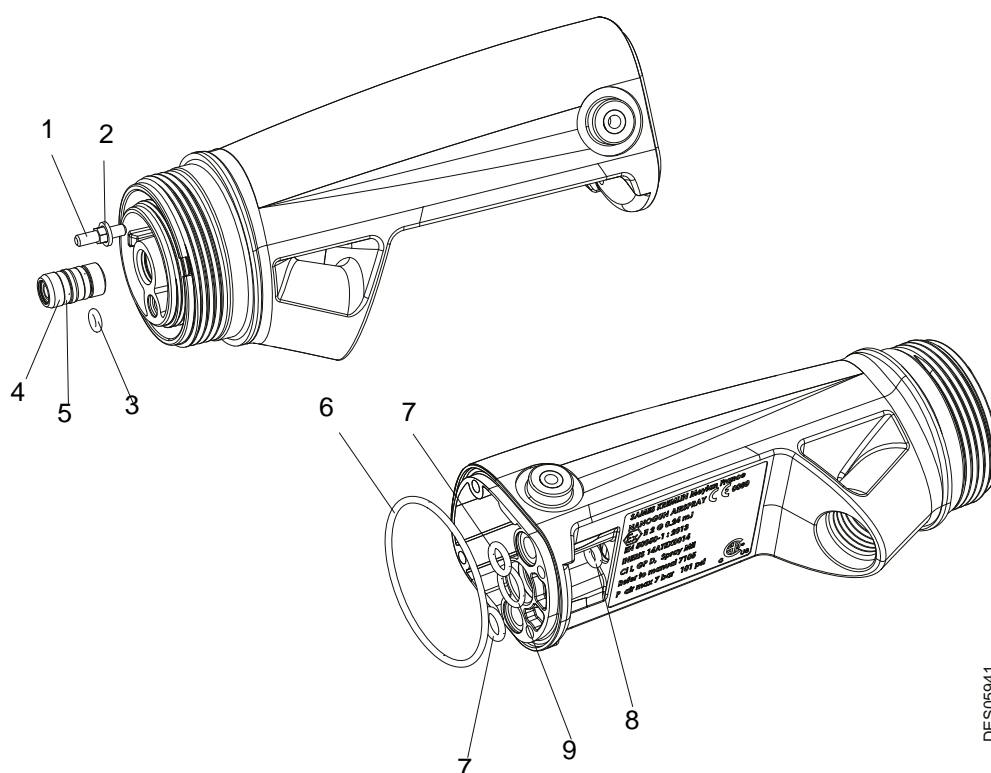

DES06941

Item	Part number	Description	Qty	Unit of sale	Spare Part Level (*)
	<b>910018202</b>	<b>Barrel assembly</b>	<b>1</b>	<b>1</b>	<b>3</b>
1	1407354	HV contact	1	1	1
2	J2CRAN031	Sealing ring of contact	1	1	1
3	J3STKL002	O-ring, chemically inert	1	1	1
4	<b>910014338</b>	<b>Seal cartridge</b>	<b>1</b>	<b>1</b>	<b>1</b>
5	J3STKL005	O-ring, chemically inert (included in item 4)	1	1	1
6	J2FENV435	O-ring FEP viton	1	1	1
7	J3STKL078	O-ring, chemically inert	2	1	1
8	J3STKL032	O-ring, chemically inert	1	1	1
9	J3STKL019	O-ring, chemically inert	1	1	1

(\*)

Level 1: Standard preventive maintenance.

Level 2: Corrective maintenance.

Level 3: Exceptional maintenance.

### 13.6. Air valve and Nut air valve

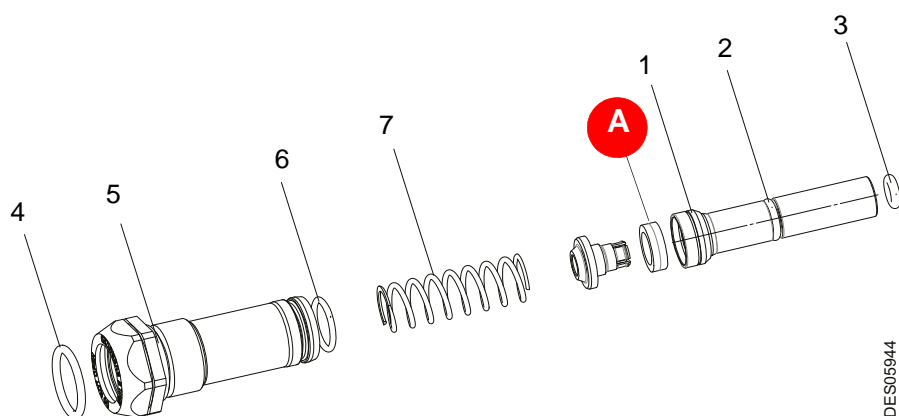

Item	Part number	Description	Qty	Unit of sale	Spare Part Level (*)
	<b>910018203</b>	<b>Air valve</b>	<b>1</b>	<b>1</b>	<b>3</b>
1	900010256	Sealing ring	1	1	1
2	J3STKL005	O-ring, chemically inert (outer of valve)	1	1	1
3	J3STKL032	O-ring, chemically inert (inner of valve)	1	1	1
	<b>910015922</b>	<b>Nut air valve equipped</b>	<b>1</b>	<b>1</b>	<b>3</b>
4	J2FTDF155	O-ring, FKM black	1	1	1
5	J2FTDF160	O-ring, FKM black	1	1	1
6	J2FTDF999	O-ring, FKM black	1	1	1
7	900009024	Air spring	1	1	1

(\*)

Level 1: Standard preventive maintenance.

Level 2: Corrective maintenance.

Level 3: Exceptional maintenance.



**WARNING** : Get back the magnet **A** on the old air valve to keep the same values of triggering.

In case of loss of the magnet, contact SAMES KREMLIN.



### 13.7. Air cap ring

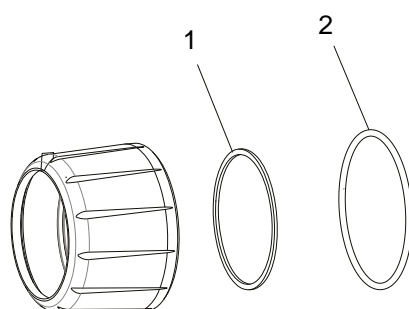

DES05945

Item	Part number	Description	Qty	Unit of sale	Spare Part Level (*)
	<b>910015921</b>	<b>Air cap ring</b>	<b>1</b>	<b>1</b>	<b>3</b>
1	900010497	Slide ring	1	1	3
2	J2FENV445	O-ring FEP/FKM	1	1	1

(\*)

Level 1: Standard preventive maintenance.

Level 2: Corrective maintenance.

Level 3: Exceptional maintenance.

### 13.8. Nozzle support

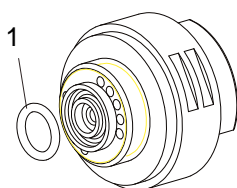

DES04110

Item	Part number	Description	Qty	Unit of sale	Spare Part Level (*)
	<b>910015721</b>	<b>Nozzle support - LP Models</b>	<b>1</b>	<b>1</b>	<b>1</b>
1	J3STKL094	O-ring - chemically inert	1	1	1

(\*)

Level 1: Standard preventive maintenance.

Level 2: Corrective maintenance.

Level 3: Exceptional maintenance.

### 13.9. Round Nozzle assemblies - LP Models

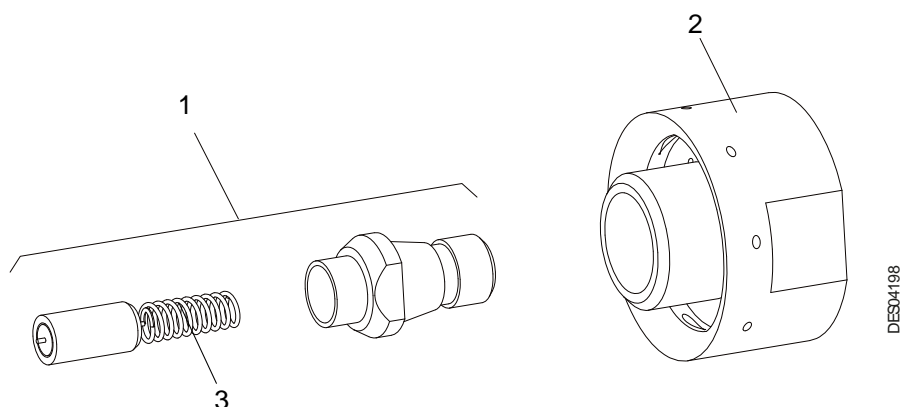

Item	Part number	Description	Qty	Unit of sale	Spare Part Level (*)
	<b>910018322</b>	<b>JR06 Nozzle assembly</b>	<b>1</b>	<b>1</b>	<b>1</b>
1	455234	Injector - Calibre 6	1	5	1
2	1305211	Vortex Nozzle	1	1	1
3	448110	Electrode (included in item1)	1	10	1

Item	Part number	Description	Qty	Unit of sale	Spare Part Level (*)
	<b>910003847</b>	<b>JR08 Nozzle assembly</b>	<b>1</b>	<b>1</b>	<b>1</b>
1	455235	Injector - Calibre 8	1	5	1
2	1305211	Vortex Nozzle	1	1	1
3	448110	Electrode (included in item1)	1	10	1

Item	Part number	Description	Qty	Unit of sale	Spare Part Level (*)
	<b>910003920</b>	<b>JR12 Nozzle assembly</b>	<b>1</b>	<b>1</b>	<b>1</b>
1	455236	Injector - Calibre 12	1	5	1
2	1305211	Vortex Nozzle	1	1	1
3	448110	Electrode (included in item1)	1	10	1

(\*)

Level 1: Standard preventive maintenance.

Level 2: Corrective maintenance.

Level 3: Exceptional maintenance.

### 13.10. Needle assembly

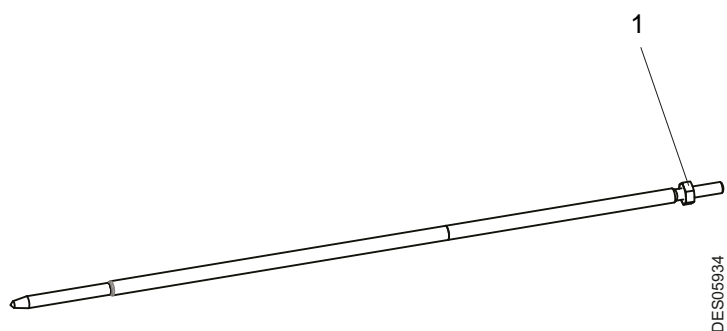

Item	Part number	Description	Qty	Unit of sale	Spare Part Level (*)
	910018219	Needle assembly	1	1	3
1	X7CEHU003	Brass H M3 U nut	1	1	3

(\*)

Level 1: Standard preventive maintenance.

Level 2: Corrective maintenance.

Level 3: Exceptional maintenance.

### 13.11. Electropneumatic coupling sets

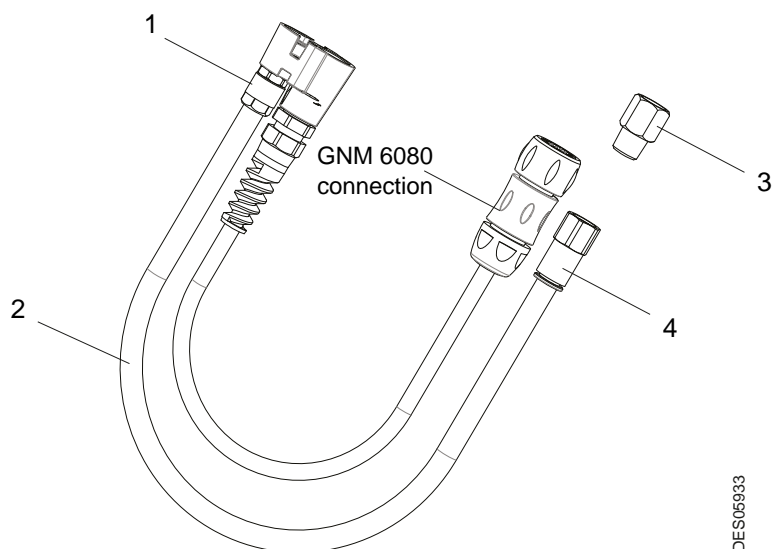

Item	Part number	Description	Qty	Unit of sale	Spare Part Level
	910015869-100	HR-LR 10m Electropneumatic coupling	1	1	3
	910015869-200	HR-LR 20m Electropneumatic coupling	1	1	3
1	900015289	Straight union - male	1	1	3
2	910021087-100	Polyurethane air hose - Ext. D: 10	10 m	m	1
	910021087-200		20 m		
3	F6RLHG362	Female NPT / Male BSP adapter	1	1	3
4	130000527	Quick coupling	1	1	3

### 13.12. Paint hoses

#### 13.12.1. For Nanogun Airspray Low Pressure and High Resistivity spray guns

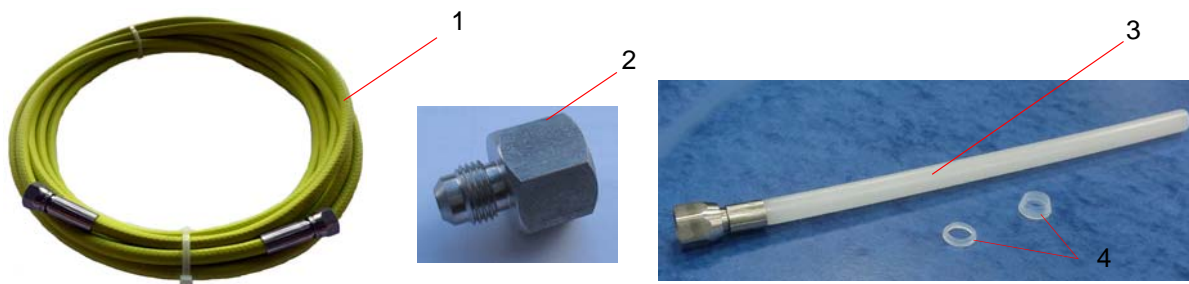

Item	Part number	Description	Qty	Unit of sale	Spare Part Level (*)
<b>For Nanogun Airspray JR/JP spray guns</b>					
1	910017065-075	HR/LP product hose - 7.5m black Dia 6	1	1	1
	910017065-150	HR/LP product hose - 15m black Dia 6	1	1	1
2	050123306	M1/2 JIC adapter - F3/8NPS	1	1	2
3	910018201	Paint hose equipped Dia:4 mm	1	1	2
4	910018200	Set of olives for outer 10 hoses (included in item 3)	1	1	2

#### 13.12.2. For Nanogun Airspray Low Pressure and Low Resistivity spray guns



Item	Part number	Description	Qty	Unit of sale	Spare Part Level (*)
<b>For Nanogun Airspray JR/JP spray guns</b>					
1	910020516-075	LR /LP product hose - 7.5m PTFE Dia 6	1	1	1
	910020516-150	LR /LP product hose - 15m PTFE Dia 6	1	1	1
2	910018200	Set of olives for outer 10 hoses	1	1	2
3	910018292	Stuffing box and nut	1	1	2

(\*)

Level 1: Standard preventive maintenance.

Level 2: Corrective maintenance.

Level 3: Exceptional maintenance.

13.12.3. For Nanogun Airspray Low Pressure and middle Resistivity spray guns

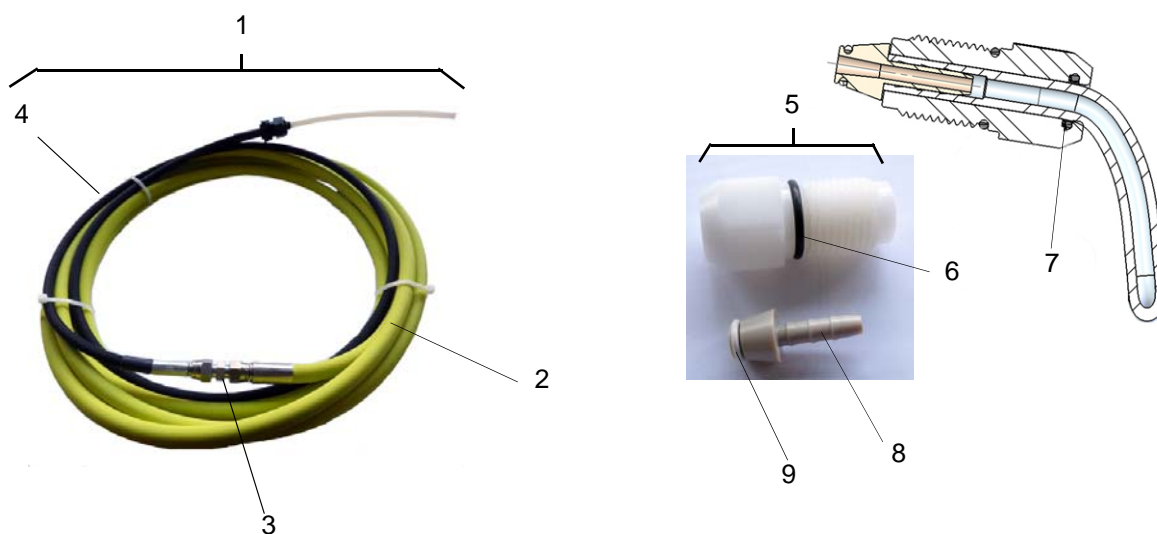

Item	Part number	Description	Qty	Unit of sale	Spare Part Level (*)
<b>For Nanogun Airspray JR/JP spray guns</b>					
1	910025601-075	MR/LP PTFE product hose- 7,5m Ø 4x8	1	1	1
	910025601-150	MR/LP PTFE product hose 15m Ø 4x8	1	1	1
2	910026304-075	Hose extension, length: 7,5 m (included in Item 1)	1	1	2
	910026304-150	Hose extension, length: 15 m (included in Item1)	1	1	2
3	050102301	Steel coupling MM 1/2" JIC (included in item1)	1	1	2
4	910026302	Whip for Nanogun Airspray LP MR (included in Item 1)	1	1	2
5	910020041	Hose paint nut with o-rings	1	1	3
6	J2FTCF178	O-ring viton (included in Item 5)	1	1	1
7	J2FTDF106	O-ring viton (inclus dans Rep.5)	1	1	1
8	900010707	Paint male connector	1	1	2
9	J3STKL005	O-ring chemically inert	1	1	1

(\*)

Level 1: Standard preventive maintenance.

Level 2: Corrective maintenance.

Level 3: Exceptional maintenance.

### 13.13. Nanogun Airspray seal set

Part number	Description	Location	Quantity
910021244	Nanogun Airspray seal set		1
J3STKL005	Chemically inert O-ring	Air valve, on/off button seal cartridge	3
J2FENV435	FEP/FKM O-ring	Barrel	1
J3STKL078	Chemically inert O-ring	Barrel	2
J3STKL019	Chemically inert O-ring	Barrel	1
J3STKL002	Chemically inert O-ring	Barrel	1
910014338	Seal cartridge	Barrel	1
J3STKL032	Chemically inert O-ring	Barrel, air valve	2
160000041	Chemically inert O-ring	Handle	1
160000067	Red FKM O-ring	Handle	1
J2FTCF018	Black FKM O-ring	Air nipple	2
J3STKL018	Chemically inert O-ring	Air nipple	1
J4BRND039	Fiber seal	Handle-barrel fastening, base-handle fastening	6
900010256	Sealing ring	Air valve	1
J3STKL094	Chemically inert O-ring	Nozzle support	1

**13.14. GNM 6080 Control module**



Item	Part number	Description	Qty	Unit of sale	Spare Part Level
	910017193	CE GNM 6080 control module	1	1	3
	910017192	CSA GNM 6080 control module (USA-CANADA only)	1	1	3
	910005759	GNM 6080 attachment kit	1	1	3
	842635	5-m ground cable, lug dia.: 6	1	1	3

(\*)

Level 1: Standard preventive maintenance.

Level 2: Corrective maintenance.

Level 3: Exceptional maintenance.

### 13.15. Options for Nanogun Airspray Low Pressure spray guns

#### 13.15.1. Flat Spray Air Caps

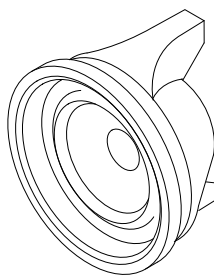

DES04202

Part number	Description	Qty	Unit of sale	Spare Part Level (*)
737549	Air Cap (flat spray)	Option	1	1
737550	SPE Air Cap (narrow flat spray)	Option	1	1
737552	SPL Air Cap (broad flat spray)	Option	1	1

(\*)

Level 1: Standard preventive maintenance.

Level 2: Corrective maintenance.

Level 3: Exceptional maintenance.

#### 13.15.2. In-line product filters

These small filters are fitted in the spray gun handle (with HR models).

Description	Part number	Versions
Filter (Male-Female 1/2 JIC)	155010100	LP HR
Screen nr 12	129609909	



**WARNING :** The filter is delivered with a 6mm screen as standard. Before installation of low pressure models, you are advised to replace the screen nr 6 from the initial design with a screen nr 12.

With LR models, it is necessary to remove the fitting F 3/8 NPT- M1/2 JIC located at the pump outlet and to replace it by the filter.



## 13.16. Appendices

### 13.16.1. Protective hose covering

This covering can be used to protect hoses and cables to ensure long life and flexibility.

Description	Part number	Unit of sale
 <p>Rilsan Protective hose covering with 30 collars</p>	910021086	50 m roll

### 13.16.2. Protective case for spray gun

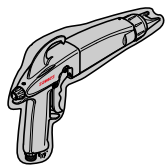
Description	Part number	Unit of sale
 <p>DES01269 Protective case</p>	900011711	10

### 13.16.3. Warning notice

Description	Part number	Unit of sale
 <p>DES00790 Warning notice</p>	1407684	1

### 13.16.4. Safety valve

Description	Part number	Unit of sale
 <p>Safety valve 6.5 bar 1/4 G</p>	903080401	1

## 14. The different versions

### 14.1. Equipments

<b>Titre</b>	<b>Pistolet Nanogun Airspray "Basse pression" LP</b>		
<i>Title</i>	<i>Nanogun Airspray Gun type "low pressure"LP</i>		
	Pistolet Nanogun Airspray CE+CSA		
<b>N° GUN</b>	<b>PISTOLET "Basse pression" LP / "Haute résistivité " HR</b>		
	<i>Low Pressure/High Resitivity GUN</i>		
	<b>CE + CSA</b>		
<b>910016710</b>	<b>HAUTE RESISTIVITE JET PLAT</b>		
<b>910018773</b>	<b>HAUTE RESISTIVITE JET ROND Ø6</b>		
<b>910016712</b>	<b>HAUTE RESISTIVITE JET ROND Ø8</b>		
<b>910016711</b>	<b>HAUTE RESISTIVITE JET ROND Ø12</b>		
<b>910017188-075</b>	<b>BASSE RESISTIVITE JET PLAT LG 7,5M</b>		
<b>910017188-150</b>	<b>BASSE RESISTIVITE JET PLAT LG 15M</b>		
<b>910018774-075</b>	<b>BASSE RESISTIVITE JET ROND Ø6 LG7,5M</b>		
<b>910018774-150</b>	<b>BASSE RESISTIVITE JET ROND Ø6 LG15M</b>		
<b>910017190-075</b>	<b>BASSE RESISTIVITE JET ROND Ø8 LG7,5M</b>		
<b>910017190-150</b>	<b>BASSE RESISTIVITE JET ROND Ø8 LG15M</b>		
<b>910017189-075</b>	<b>BASSE RESISTIVITE JET ROND Ø12 LG7,5M</b>		
<b>910017189-150</b>	<b>BASSE RESISTIVITE JET ROND Ø12 LG15M</b>		
<b>N° GUN</b>	<b>EQUIPEMENT Nanogun Airspray CE</b>	<b>N° GUN</b>	<b>EQUIPEMENT Nanogun Airspray US / CSA</b>
	<i>SET Nanogun Airspray CE</i>		<i>SET Nanogun Airspray US / CSA</i>
<b>910017223-07</b>	<b>E.NANOGUN LP/HR JP LG7,5 EU</b>	<b>910017223-072</b>	<b>E.NANOGUN LP/HR JP LG7,5 US</b>
<b>910017223-15</b>	<b>E.NANOGUN LP/HR JP LG15 EU</b>	<b>910017223-152</b>	<b>E.NANOGUN LP/HR JP LG15 US</b>
<b>910017224-07</b>	<b>E.NANOGUN LP/HR JRØ8 LG7,5 EU</b>	<b>910017224-072</b>	<b>E.NANOGUN LP/HR JRØ8 LG7,5 US</b>
<b>910017224-15</b>	<b>E.NANOGUN LP/HR JRØ8 LG15 EU</b>	<b>910017224-152</b>	<b>E.NANOGUN LP/HR JRØ8 LG15 US</b>
<b>910017741-07</b>	<b>E.NANOGUN LP/HR JRØ12 LG7.5</b>	<b>910017741-072</b>	<b>E.NANOGUN LP/HR JRØ12 LG7.5US</b>
<b>910017741-15</b>	<b>E.NANOGUN LP/ HR JRØ12 LG15 EU</b>	<b>910017741-152</b>	<b>E.NANOGUN LP/ HR JRØ12 LG15 US</b>
<b>910017221-07</b>	<b>E.NANOGUN LP/LR JP LG7,5 EU</b>	<b>910017221-072</b>	<b>E.NANOGUN LP/LR JP LG7,5 US</b>
<b>910017221-15</b>	<b>E.NANOGUN LP/LR JP LG15 EU</b>	<b>910017221-152</b>	<b>E.NANOGUN LP/LR JP LG15 US</b>
<b>910017222-07</b>	<b>E.NANOGUN LP/LR JRØ8 LG7,5 EU</b>	<b>910017222-072</b>	<b>E.NANOGUN LP/LR JRØ8 LG7,5 US</b>
<b>910017222-15</b>	<b>E.NANOGUN LP/LR JRØ8 LG15 EU</b>	<b>910017222-152</b>	<b>E.NANOGUN LP/LR JRØ8 LG15 US</b>
<b>910017742-07</b>	<b>E.NANOGUN LP/LR JRØ12 LG7,5 EU</b>	<b>910017742-072</b>	<b>E.NANOGUN LP/LR JRØ12 LG7,5 US</b>
<b>910017742-15</b>	<b>E.NANOGUN LP/LR JRØ12 LG15 EU</b>	<b>910017742-152</b>	<b>E.NANOGUN LP/LR JRØ12 LG15 US</b>
<b>N°</b>	<b>Module GNM 6080 CE</b>	<b>N°</b>	<b>Module GNM 6080 US/CSA</b>
	<i>Control module GNM 6080 CE</i>		<i>Control module GNM 6080 US/CSA</i>
<b>910017193</b>	<b>MODULE DE COMMANDE GNM 6080 VERSION EUROPE</b>	<b>910017192</b>	<b>MODULE DE COMMANDE GNM 6080 VERSION US</b>
<b>N°</b>	<b>CABLE Nanogun Airspray CE / CSA</b>		
	<i>Cable Nanogun Airspray CE / CSA</i>		
<b>910015869-100</b>	<b>CABLE ELECTRO 10 Mètres</b>		
<b>910015869-200</b>	<b>CABLE ELECTRO 20 Mètres</b>		
<b>N°</b>	<b>TUYAU PRODUIT Nanogun Airspray CE / CSA</b>		
	<i>Hose Nanogun Airspray CE / CSA</i>		
<b>910017065-075</b>	<b>Tuyau produit HR-7,5M</b>		
<b>910017065-150</b>	<b>Tuyau produit HR-15M</b>		
<b>910020516-075</b>	<b>Tuyau produit LR-7,5M</b>		
<b>910020516-150</b>	<b>Tuyau produit LR-15M</b>		

DES05994

<b>Titre</b>	<b>Pistolet Nanogun Airspray "Basse pression" LP</b>		
<b>Title</b>	<i>Nanogun Airspray Gun type "low pressure"LP</i>		
	Pistolet Nanogun Airspray CE+CSA		
<b>N° GUN</b>	PISTOLET "Basse pression" LP / Moyenne résistivité " MR <i>Low Pressure/Middle Resistivity GUN</i> <b>CE + CSA</b>		
<b>910025604-075</b>	MOYENNE RESISTIVITE JET ROND Ø8		
<b>910025604-150</b>	MOYENNE RESISTIVITE JET ROND Ø8		
<b>910025605-075</b>	MOYENNE RESISTIVITE JET ROND Ø12		
<b>910025605-150</b>	MOYENNE RESISTIVITE JET ROND Ø12		
<b>910025606-075</b>	MOYENNE RESISTIVITE JET PLAT		
<b>910025606-150</b>	MOYENNE RESISTIVITE JET PLAT		
<b>N° GUN</b>	<b>EQUIPEMENT Nanogun Airspray CE</b> <i>SET Nanogun Airspray CE</i>	<b>N° GUN</b>	<b>EQUIPEMENT Nanogun Airspray US / CSA</b> <i>SET Nanogun Airspray US / CSA</i>
<b>910025622-07</b>	<a href="#">E.NANOGUN LP/MR JP LG7,5 EU</a>	<b>910025622-072</b>	<a href="#">E.NANOGUN LP/MR JP LG7,5 US</a>
<b>910025622-15</b>	<a href="#">E.NANOGUN LP/MR JP LG15 EU</a>	<b>910025622-152</b>	<a href="#">E.NANOGUN LP/MR JP LG15 US</a>
<b>910025620-07</b>	<a href="#">E.NANOGUN LP/MR JRØ8 LG7,5 EU</a>	<b>910025620-072</b>	<a href="#">E.NANOGUN LP/MR JRØ8 LG7,5 US</a>
<b>910025620-15</b>	<a href="#">E.NANOGUN LP/MR JRØ8 LG15 EU</a>	<b>910025620-152</b>	<a href="#">E.NANOGUN LP/MR JRØ8 LG15 US</a>
<b>910025621-07</b>	<a href="#">E.NANOGUN LP/MR JRØ12 LG7,5 EU</a>	<b>910025621-072</b>	<a href="#">E.NANOGUN LP/MR JRØ12 LG7,5 US</a>
<b>910025621-15</b>	<a href="#">E.NANOGUN LP/MR JRØ12 LG15 EU</a>	<b>910025621-152</b>	<a href="#">E.NANOGUN LP/MR JRØ12 LG15 US</a>
<b>N°</b>	<b>Module GNM 6080 CE</b> <i>Control module GNM 6080 CE</i>	<b>N°</b>	<b>Module GNM 6080 US/CSA</b> <i>Control module GNM 6080 US/CSA</i>
<b>910017193</b>	MODULE DE COMMANDE GNM 6080 VERSION EUROPE	<b>910017192</b>	MODULE DE COMMANDE GNM 6080 VERSION US
<b>N°</b>	<b>CABLE Nanogun Airspray CE / CSA</b> <i>Cable Nanogun Airspray CE / CSA</i>		
<b>910015869-100</b>	CABLE ELECTRO 10 Mètres		
<b>910015869-200</b>	CABLE ELECTRO 20 Mètres		
<b>N°</b>	<b>TUYAU PRODUIT Nanogun Airspray CE / CSA</b> <i>Hose Nanogun Airspray CE / CSA</i>		
<b>910025601-075</b>	Tuyau produit MR-7,5M		
<b>910025601-150</b>	Tuyau produit MR-15M		

DIS06947

## 14.2. Configuration

Configuration	Part Number	GNM6080 CE	GNM6080 US / CSA	Electropneumatic coupling set 10cm	Electropneumatic coupling set 20cm	HR product hose 7.5m	HR product hose 15m	LR product hose 7.5m	LR product hose 15m	MR product hose 7.5m	MR product hose 15m	Injector / Cap 6 mm 455234 900011385	Injector / Cap 8 mm 455235 900010903	Injector / Cap 12 mm 455238 900010904	Injector / Flat spray cap 1406402 900009614
<b>Spray guns</b>															
Spray gun LP/HR flat spray JP	910017192														
Spray gun LP/HR round spray JR 06	910018710														
Spray gun LP/HR round spray JR 08	910018712														
Spray gun LP/HR round spray JR 12	910018711														
<b>Spray gun LP/LR flat spray JP</b>															
Spray gun LP/LR flat spray JP	910017188-075					X									
Spray gun LP/LR round spray JR 06	910017188-150					X									
Spray gun LP/LR round spray JR 08	910018744-075					X									
Spray gun LP/LR round spray JR 08	910018744-150					X									
Spray gun LP/LR round spray JR 12	910017190-150					X									
Spray gun LP/LR round spray JR 12	910017188-075					X									
Spray gun LP/LR round spray JR 12	910017188-150					X									
<b>Equipments</b>															
Equip. Nanogun Airspray LP/HR JP LG 7.5 EU	910017224-07	X													
Equip. Nanogun Airspray LP/HR JP LG 15 EU	910017224-15	X													
Equip. Nanogun Airspray LP/HR JR 8 LG 7.5 EU	910017224-15	X													
Equip. Nanogun Airspray LP/HR JR 8 LG 15 EU	910017224-15	X													
Equip. Nanogun Airspray LP/HR JR 12 LG 7.5 EU	91001741-07	X													
Equip. Nanogun Airspray LP/HR JR 12 LG 15 EU	91001741-15	X													
Equip. Nanogun Airspray LP/LR JP LG 7.5 EU	910017221-07	X													
Equip. Nanogun Airspray LP/LR JP LG 15 EU	910017221-15	X													
Equip. Nanogun Airspray LP/LR JR 8 LG 7.5 EU	910017224-07	X													
Equip. Nanogun Airspray LP/LR JR 8 LG 15 EU	910017224-15	X													
Equip. Nanogun Airspray LP/LR JR 12 LG 7.5 EU	91001742-07	X													
Equip. Nanogun Airspray LP/LR JR 12 LG 15 EU	91001742-15	X													
Equip. Nanogun Airspray LP/HR JP LG 7.5 USC/CSA	910017221-072		X												
Equip. Nanogun Airspray LP/HR JP LG 15 USC/CSA	910017221-152		X												
Equip. Nanogun Airspray LP/HR JR 8 LG 7.5 USC/CSA	910017224-072		X												
Equip. Nanogun Airspray LP/HR JR 8 LG 15 USC/CSA	910017224-152		X												
Equip. Nanogun Airspray LP/HR JR 12 LG 7.5 USC/CSA	91001742-072		X												
Equip. Nanogun Airspray LP/HR JR 12 LG 15 USC/CSA	91001742-152		X												
Equip. Nanogun Airspray LP/LR JP LG 7.5 USC/CSA	910017221-072		X												
Equip. Nanogun Airspray LP/LR JP LG 15 USC/CSA	910017221-152		X												
Equip. Nanogun Airspray LP/LR JR 8 LG 7.5 USC/CSA	910017224-072		X												
Equip. Nanogun Airspray LP/LR JR 8 LG 15 USC/CSA	910017224-152		X												
Equip. Nanogun Airspray LP/LR JR 12 LG 7.5 USC/CSA	91001742-072		X												
Equip. Nanogun Airspray LP/LR JR 12 LG 15 USC/CSA	91001742-152		X												
Equip. Nanogun Airspray LP/HR JP LG 7.5 EU	910025622-07	X													
Equip. Nanogun Airspray LP/HR JP LG 15 EU	910025622-15	X													
Equip. Nanogun Airspray LP/HR JR 8 LG 7.5 EU	910025620-07	X													
Equip. Nanogun Airspray LP/HR JR 8 LG 15 EU	910025620-15	X													
Equip. Nanogun Airspray LP/HR JR 12 LG 7.5 EU	910025621-07	X													
Equip. Nanogun Airspray LP/HR JR 12 LG 15 EU	910025621-15	X													
Equip. Nanogun Airspray LP/HR JP LG 7.5 USC/CSA	910025622-072	X													
Equip. Nanogun Airspray LP/HR JP LG 15 USC/CSA	910025622-152	X													
Equip. Nanogun Airspray LP/HR JR 8 LG 7.5 USC/CSA	910025620-072	X													
Equip. Nanogun Airspray LP/HR JR 8 LG 15 USC/CSA	910025620-152	X													
Equip. Nanogun Airspray LP/HR JR 12 LG 7.5 USC/CSA	910025621-072	X													
Equip. Nanogun Airspray LP/HR JR 12 LG 15 USC/CSA	910025621-152	X													